

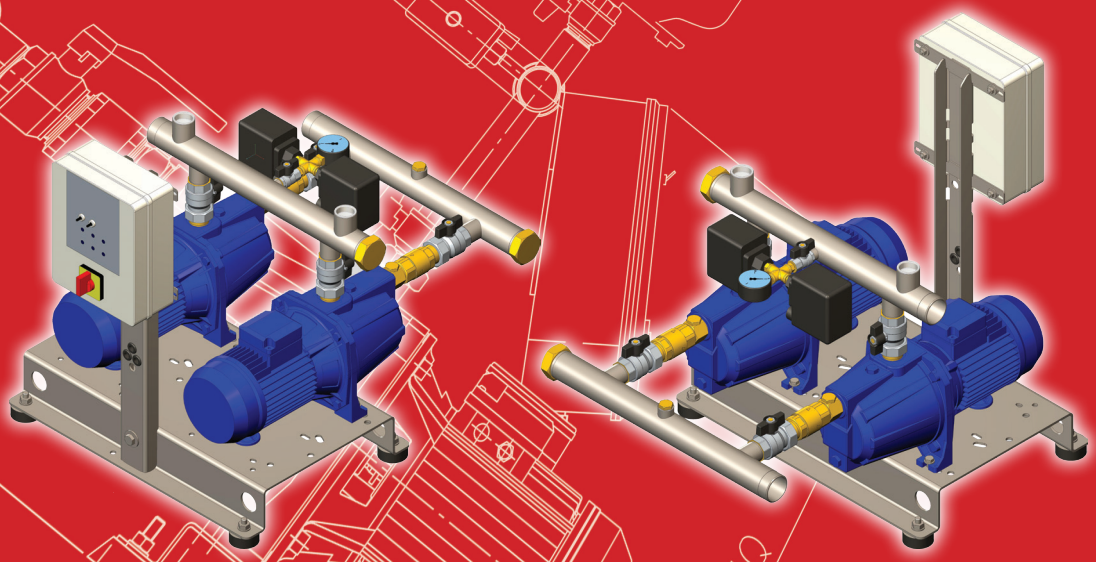

Japanese Technology since 1912

## AGA Booster Sets

Data Book 50Hz

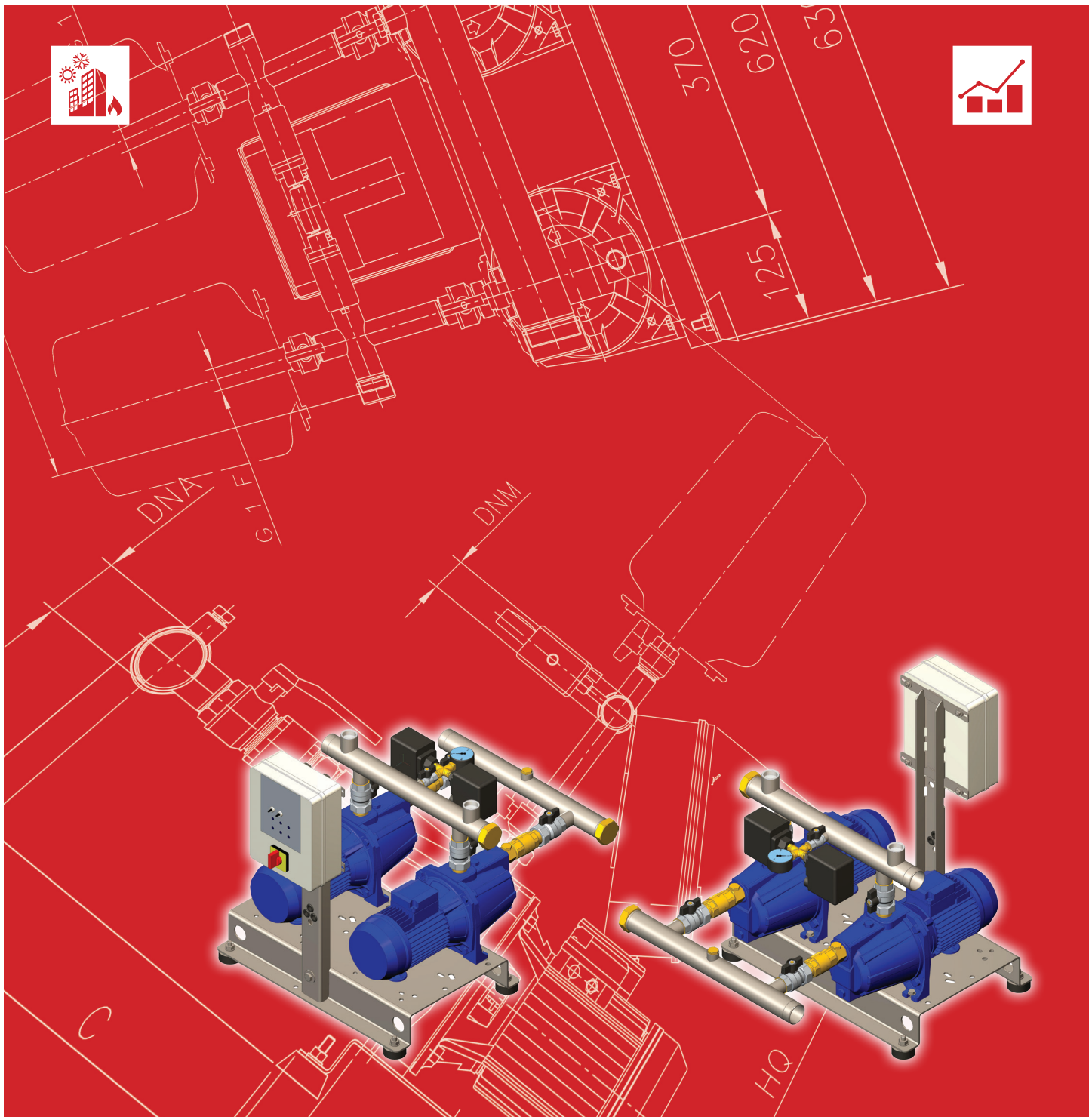

## INDEX

Page

<b>INDEX</b>	
<b>DEFINITION AND USE OF PRESSURISATION UNITS</b>	<b>101</b>
<b>TYPICAL APPLICATIONS</b>	<b>101</b>
<b>PRINCIPLE OF OPERATION OF GP PRESSURISATION UNITS</b>	<b>101</b>
<b>PRINCIPLE OF OPERATION OF GPE PRESSURISATION UNITS</b>	<b>101</b>
<b>OPERATING CONDITIONS</b>	<b>102</b>
TESTS AND TRIALS	102
MECHANICAL AND HYDRAULIC TESTS	102
ELECTRICAL TESTS	102
Principle of Operation of GPE Pressurisation UNITS with E-drive	102
Principle of Operation of GPE Pressurisation UNITS with E-power and Hydrocontroller	102
Principle of Operation of GPE Pressurisation UNITS with an EFC control panel	103
Principle of Operation of GPE Pressurisation UNITS with an MFC control panel	103
Fig. 1 - TWO PUMP UNIT WITH CONSTANT PRESSURE REGULATION	104
PRESSURISATION UNIT WATER CIRCUIT DIAGRAM	104
<b>TYPE KEY</b>	<b>105</b>
<b>NAME PLATE</b>	<b>105</b>
<b>PRODUCT SPECIFICATIONS</b>	<b>201</b>
HYDRAULIC COMPONENTS AND CONTROL	201
ELECTRIC PANEL	202
TECHNICAL PUMP DATA	202
TECHNICAL MOTOR DATA	203
<b>PERFORMANCE RANGE</b>	<b>301</b>
RESEAU BOOSTER SET 2GP AGA	301
<b>CURVE SPECIFICATION 2GP</b>	<b>401</b>
SELECTION CHART 2GP AGA	402
<b>PERFORMANCE CURVE 2GP</b>	<b>403</b>
2GP AGA 1.00(M)	403
2GP AGA 1.50(M)	404
2GP AGA 2.00(M)	405
2GP AGA 3.00	406
<b>2GP CONSTRUCTION</b>	<b>601</b>
EXTERNAL VIEW 2GP AGA 1.00-1.50-2.00	601
EXTERNAL VIEW 2GP AGA 3.00	602
<b>OVERALL DIMENSIONS 2GP BOOSTER SET</b>	<b>701</b>
2GP AGA	701

PACKING	702
CONTROL PANEL FIXED SPEED	801
2EP SPECIFICATION	801

① click INDEX to jump CORRESPONDING SECTION

INTENTIONALLY EMPTY PAGE

### DEFINITION AND USE OF PRESSURISATION UNITS

In situations in which a municipal water mains is lacking or insufficient for the proper operation of the services, one must install a pressurization unit to provide acceptable pressure and flow rates to even in the most unfavourable services. Pressurisation units are used wherever there is a need to increase the pressure, or to pressurise a water circuit. **EBARA GP pressurisation units** are automatic systems with 2 or more pumps operating in parallel, designed to provide a simple and reliable solution to the most common requirements for maintenance of water supply pressure for apartment buildings, hotels, centres, offices and schools as well as providing auxiliary service in industrial and agricultural applications. They stand out for their robust construction, compact size, excellent efficiency and silent operation. GP units are equipped for connection to membrane and air cushion autoclaves. They are controlled by pressure switches or, for units with INVERTER control, by the signal from a pressure transducer.

### TYPICAL APPLICATIONS

INDUSTRY	BUILDING SERVICE	WATER SUPPLY
		

### PRINCIPLE OF OPERATION OF GP PRESSURISATION UNITS

When water is demanded, it is first drawn from the autoclave tank (if present). This demand for water, with the pumps stopped, lowers the pressure until the pressure switch with the highest setpoint trips and starts the first electropump. If the output flow is greater than the delivery capacity of a single pump, the pressure continues falling until it trips the second pressure switch, thus starting the second pump. This happens for all pumps in the unit. When the water demand stops or reduces, the system pressure rises, thus opening the pressure switches sequentially and shutting off the pumps one by one. This is done in inverse order to that in which the motors were started up, the number of hourly starts per pump is reduced and they are all used to the same extent.

NB: By connecting a float switch or minimum pressure switch to the control panel (both for demand from the first accumulation tank and from the water circuit itself) one can prevent the most frequent cause of pump failure: dry running.

### PRINCIPLE OF OPERATION OF GPE PRESSURISATION UNITS

**GPE** units are designed to operate with a pump controlled by an **INVERTER** in the control panel, on board the motor, or in-line. The unit thus maintains constant pressure in the water circuit.

There are various versions of GPE unit:

- With INVERTER in the control panel (Standard **EFC** version)  
With a single INVERTER controlling a single pump which is alternated with the others at each start up (MFC version, on request, in which each pump is INVERTER controlled).
- With multiple INVERTERS, each pump controlled by its own INVERTER (**MFC versions**, versions with INVERTER on board motor or in-line INVERTER)

**Note: Not all control options shown in the introduction are available with AGA pumps**

## OPERATING CONDITIONS

EBARA GP-GPE pressurisation units can be used, in their standard versions, for civil, industrial and agricultural applications, as follows:

- building service
- water lifting and handling
- A/C
- heating
- irrigation
- washing systems

The conveyed fluid must be: clean, potable, ground or mixed water, free of solid or fibrous suspensions and aggressive chemical substances.

The units must be installed under cover, protected from the weather and freezing.

- Conveyed water temperature 0 - 50°C (depending on pumps).
- Ambient operating temperature 0 - 40°C, no higher than 1000 m above sea level.
- Max relative humidity 50% at +40°C.

NB: The system available NPSH must be greater than the NPSH demanded from the pump. For applications with different technical specifications, uses and climatic conditions (type of vector fluid, marine and aggressive industrial conditions), please contact our sales network.

## TESTS AND TRIALS

Before shipping, all EBARA pressurisation units are subject to hydraulic, mechanical and electrical testing.

### MECHANICAL AND HYDRAULIC TESTS

- Pressure switch calibration
- Pump direction of rotation
- Mechanical testing of moving parts and running noise (on each pump)
- Tightness test with delivery port closed and nameplate rating tests
- MANUAL trials (using button on control panel) for each pump
- AUTOMATIC trials (using switch on control panel) for unit

### ELECTRICAL TESTS

- Earthing system continuity
- Applied voltage (dielectric rigidity)
- Insulation resistance

### Principle of Operation of GPE Pressurisation UNITS with E-drive

GPE units with E-drive are designed to operate with each pumps controlled by an INVERTER installed on board its motor. The system is controlled by an MASTER INVERTER in relation to the reference signal supply by a pressure transmitters (4 - 20 mA passive). As the system pressure varies, the MASTER pump varies its rotary speed to restore it to the setpoint. If the water demand exceeds the capacity of the pump, the second variable speed pump cuts in and, pump goes into regulation mode to maintain the pressure setpoint; this happens for all the pumps in the unit. If the water demand drops off, the pressure tends to increase and the latest pump gradually reduces its speed to restore the correct operating pressure. This results in the regulation of the speed of the other pumps, until they gradually turn off. Once the system pressure has been restored and the water demand is 0, the MASTER pump switches off automatically.

### Principle of Operation of GPE Pressurisation UNITS with E-power and Hydrocontroller

GPE units with E-power and Hydrocontroller are two pumps unit and are designed to operate with pumps controlled by an INVERTER in-line type. As the system pressure varies, the MASTER pump varies its rotary speed to restore it to the setpoint. If the water demand exceeds the capacity of the pump, the second variable speed pump cuts in and, the two pumps rotate at variable synchronous speed to restore the operating pressure. If the water demand drops off, the pressure tends to increase and both pumps gradually reduces its speed to restore the correct operating pressure. This results in the regulation of the speed of the other pumps, until they gradually turn off when the water demand is 0.

**Principle of Operation of GPE Pressurisation UNITS with an EFC control panel**

EFC multiple pump control units power pump n. 1 with the INVERTER to modulate system performance in relation to the reference signal while the other pumps are run at maximum nominal speed (around 2900 rpm) and started and stopped in relation to demand. These means there are two distinct primary electrical circuits:

- n. 1 - INVERTER startup/control of a single pump,
- n. 2 - contactor startup (direct or star/delta) of the other pumps.

The system is controlled by an electronic controller in relation to the reference signal supply by a pressure transmitter, flow meter or other unified control signal (4 - 20 mA passive).

If the electronic controller or pressure transducer fails, a system of pressure switches controls the pumps directly (if present).

- In case of water distribution at constant pressure (Fig.1), the electronic controller is connected to the pressure transmitter on the units' delivery manifold, which outputs a signal proportional to the circuit pressure. When the pressure drops due to water demand, the pressure transmitter signal also drops and the controller starts and controls the speed of the first pump with the INVERTER to restore the reference/ operating pressure. If the pump's flow rate is lower than demand, the circuit pressure will continue to drop and the system responds by increasing the pump's speed. Once pump n. 1 reaches its maximum speed and demand is still in excess of its delivery, the controller will start pump n. 2 at maximum speed. The speed of pump n. 1 is immediately modulated so as to establish the operating pressure. If the pressure drops even further and pump n. 1 is once again running at maximum speed, the controller starts up pump n. 3, and so on for all pumps in the unit. If the water demand drops off, the pressure tends to increase and the controller reduces the speed of pump n. 1 to restore the correct operating pressure. At this point, the controller will stop one of the pumps running at maximum speed, while the speed of pump n. 1 is modulated to maintain the reference pressure. As the pressure continues to increase due to reduced demand, once the minimum speed of pump n. 1 is reached once more the controller will stop pump n. 3 and then pump n. 2. Once the demand for water has completely ceased, the controller reduces the speed of pump n. 1 to its minimum and after a set delay (around 1 minute) stops this pump too. The next time the system is started up, the INVERTER controlled pump will no longer be pump n. 1, but n. 2. The INVERTER controlled pump thus rotates through all pumps in sequence.

**Principle of Operation of GPE Pressurisation UNITS with an MFC control panel**

MFC multiple pump control panels power each pump with an INVERTER to modulate system performance in relation to the reference signal. MFC controllers differ from EFC controller from the point of view of their construction, since instead of having a single INVERTER to control all the pumps, each pump has its own INVERTER. The two types of control panel differ in construction, but they have the same type of operation by the controller, which responds to the reference signal output by a pressure transmitter or other unified control (4 - 20 mA passive). If the electronic controller or pressure transducer fails, a system of pressure switches controls the INVERTERS directly.

- In case of water distribution at constant starting pressure (Fig.1), the electronic controller is connected to the pressure transmitter on the units' delivery manifold, which outputs a signal proportional to the circuit pressure. When the pressure drops due to water demand, the pressure transmitter signal also drops and the controller starts and controls the speed of the first pump with the INVERTER to restore the reference/ operating pressure. If the pump's flow rate is lower than demand, the circuit pressure will continue to drop and the system responds by increasing the pump's speed. Once pump n. 1 reaches its maximum speed and demand is still in excess of its delivery, the controller will start pump n. 2, also at variable synchronous speed. The controller will modulate the speed of the two pumps to restore the operating pressure; the modulating frequency is the same for both pumps. If the pressure drops even further and pumps n. 1 and 2 are once again running at maximum speed, the controller starts up pump n. 3, and then pump n. 4, if present. When the water demand is reduced the pressure will end to increase, as does the pressure transmitter output value. The controller thus reduces the speed of pumps n. 1, 2, 3 and 4 (they are all controlled at the same speed) to restore the reference/ operating pressure. If the pumps' flow rate is greater than demand, the circuit pressure will continue to increase and the system responds by decreasing the speed of the pumps until it reaches the minimum speed setting. At this point, the controller will stop pump n. 4, while the speed of pumps n. 1, 2 and 3 is modulated to maintain the reference pressure. As the pressure continues to increase due to reduced demand, once the minimum speed setting is reached again, the controller will stop pump n. 3 and modulate the speed of pumps n. 1 and 2. This continues in sequence as the demand continues to fall, until the unit is completely stopped.

Fig. 1 - TWO PUMP UNIT WITH CONSTANT PRESSURE REGULATION

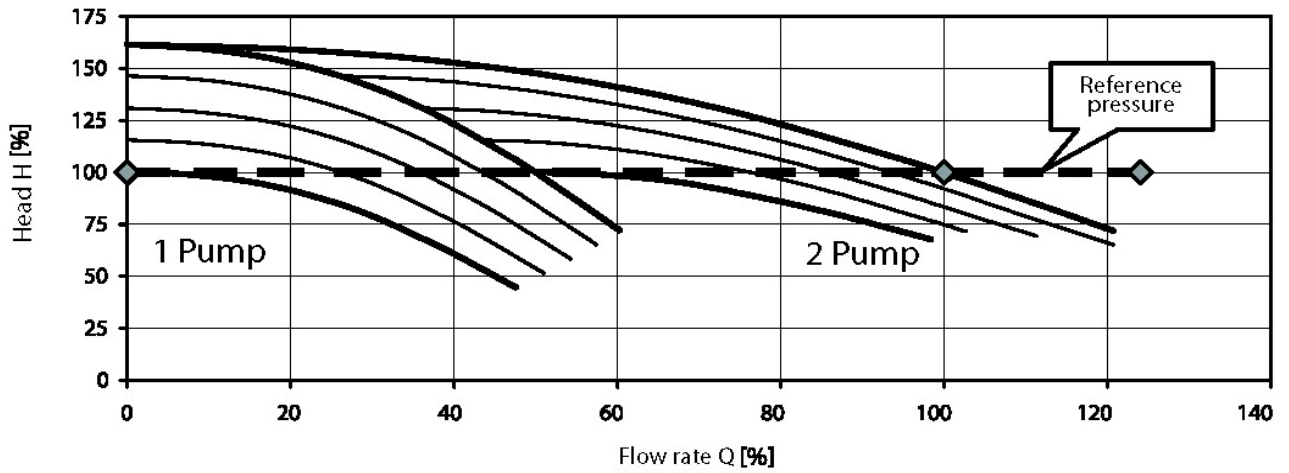

PRESSURISATION UNIT WATER CIRCUIT DIAGRAM

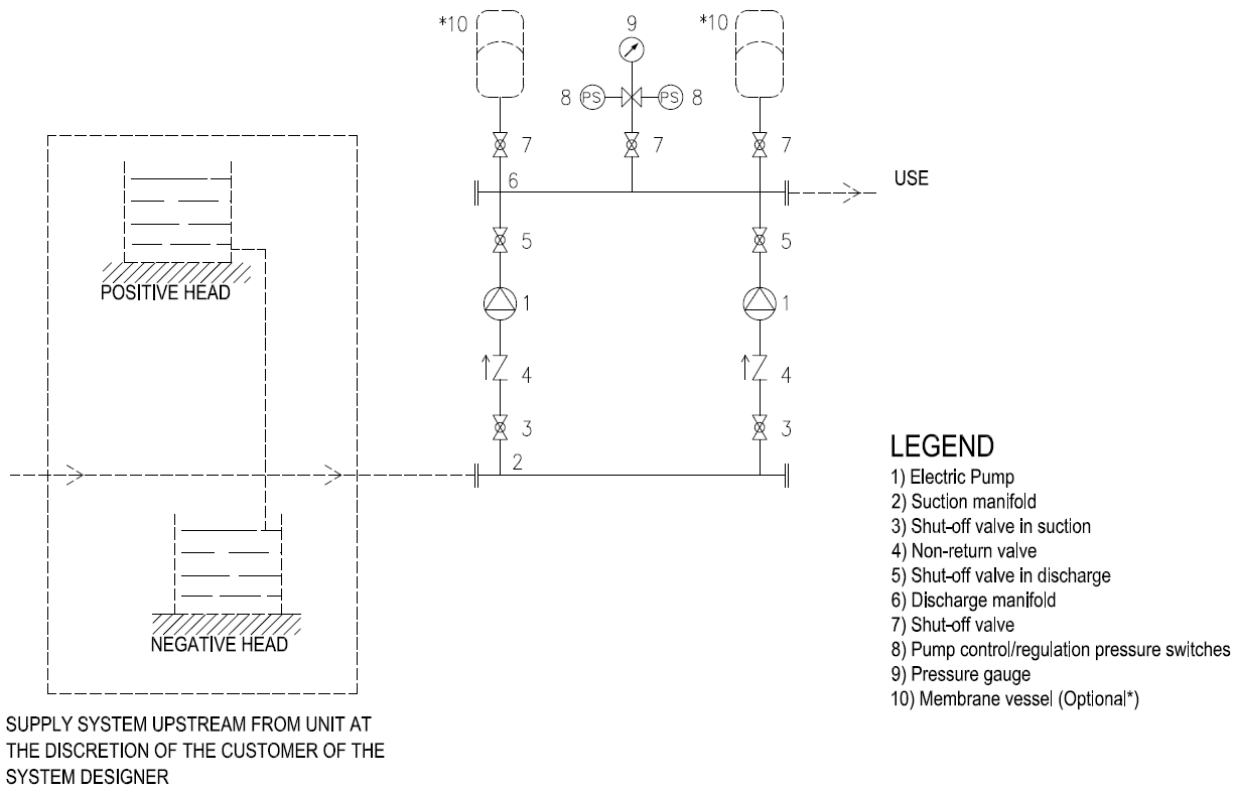



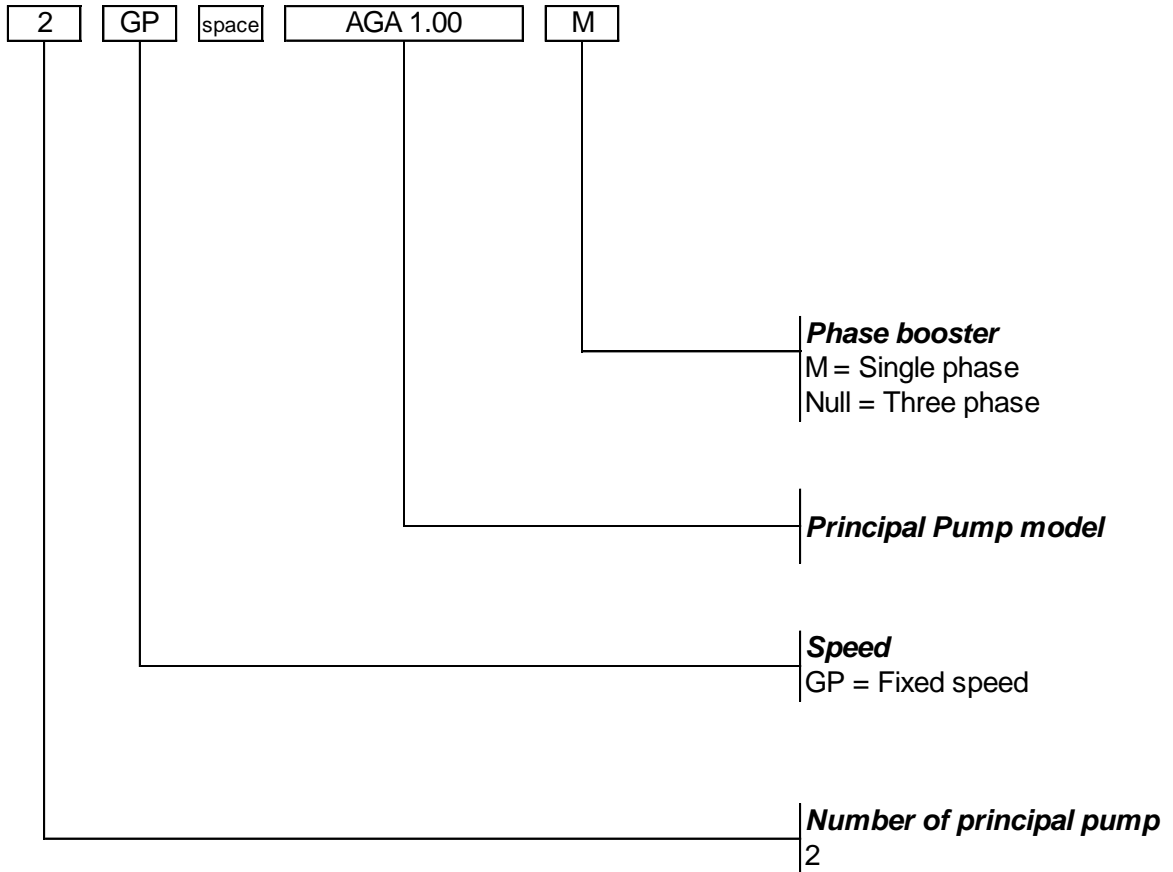

### TYPE KEY

#### 2GP AGA



### NAME PLATE

 <b>EBARA</b> Via Campo Sportivo, 30 38023 CLES (TN) ITALY		 MADE IN ITALY
BOOSTER UNIT		
TYPE	①	
P/N	②	
S/N	③	

- 1) "TYPE" booster model
- 2) "P/N" booster item number
- 3) "S/N" booster serial number

INTENTIONALLY EMPTY PAGE

### PRODUCT SPECIFICATIONS HYDRAULIC COMPONENTS AND CONTROL

BOOSTER SET							
AGA							
Operating range	Model		1.00	1.50	2.00	3.00	
	Nominal flow rate ( m <sup>3</sup> /h )	Single pump		3.6	6.0		
		2GP		7.2	12.0		
	Maximum working pressure			10 bar			
	Liquid temperature range			0÷45°C			
	Ambient operating temperature (no higher than 1000 m above sea level)			0÷40°C			
Hydraulic components	Frame		Omega sheet Galvanized steel				
	Manifold suction / discharge		Threaded manifold Galvanized steel				
	Closing manifold		Threaded female cap Brass				
	Check valve		Threaded check valve Brass / NBR				
	Ball valve		Threaded ball valve Brass / PTFE				
	Socket for air feeders		Threaded socket Brass				
Control	Pressure gauge		M3A-ABS 50/FR / plastic-copper alloy				
	Pressure switches		GP version with EP panel fixed speed XMP / -25°C...+70°C				

## ELECTRIC PANEL

BOOSTER SET						
AGA						
Operating range	Model		1.00	1.50	2.00	3.00
	Nominal flow rate ( m <sup>3</sup> /h )	Single pump	3.6	6.0		
		2GP	7.2	12.0		
	Maximum working pressure		10 bar			
Control panel	Principal Electric panel		EP fixed speed			

## TECHNICAL PUMP DATA

PUMP					
AGA					
Operating range	Model	1.00	1.50	2.00	3.00
	Maximum working pressure		1 MPa ( 10 bar )		
	Liquid temperature range		+5°C to +45°C		
Liquid handled	Liquid type	Clean water			
Key components material	Casing	Cast iron			
	Impeller	PPE+PS glass fibre reinforced	Brass		
	Casing cover	AISI 304	Cast iron built-in on the motor bracket		
	Shaft seal	Ceramic/Carbon/NBR			
	Shaft	AISI 303 ( wet extension )			
	Bracket	Aluminum	Cast iron		
	Diffuser	PPE+PS glass fibre reinforced			
Pipe connection	Suction	G 1"	G 1" ½		
		UNI ISO 228			
	Discharge	G 1" UNI ISO 228			

### TECHNICAL MOTOR DATA

MOTOR				
AGA				
Power source	Frequency	50 Hz		
	Phase	Single-phase	Three-phase	
	Rotation speed	2800 min <sup>-1</sup>		
	Power rating	0.75 ÷ 1.5 kW	0.75 ÷ 2.2 kW	
		1 ÷ 2 HP	1 ÷ 3 HP	
Voltage	230 ± 10% V	230/400 ± 10%		
Type	Type	Electric - TEFC		
	Efficiency level	-	IE3 from 0.75 kW up to 2.2 kW	
	N° of poles	2		
	Protection degree	IP 44		
	Insulation class	F		
Others	Capacitor	Built in	-	
	Overload protection	Built in	Provided by the user	
	Casing Material	Aluminium		
	Motor support	Cast iron		

INTENTIONALLY EMPTY PAGE

### PERFORMANCE RANGE RESEAU BOOSTER SET 2GP AGA

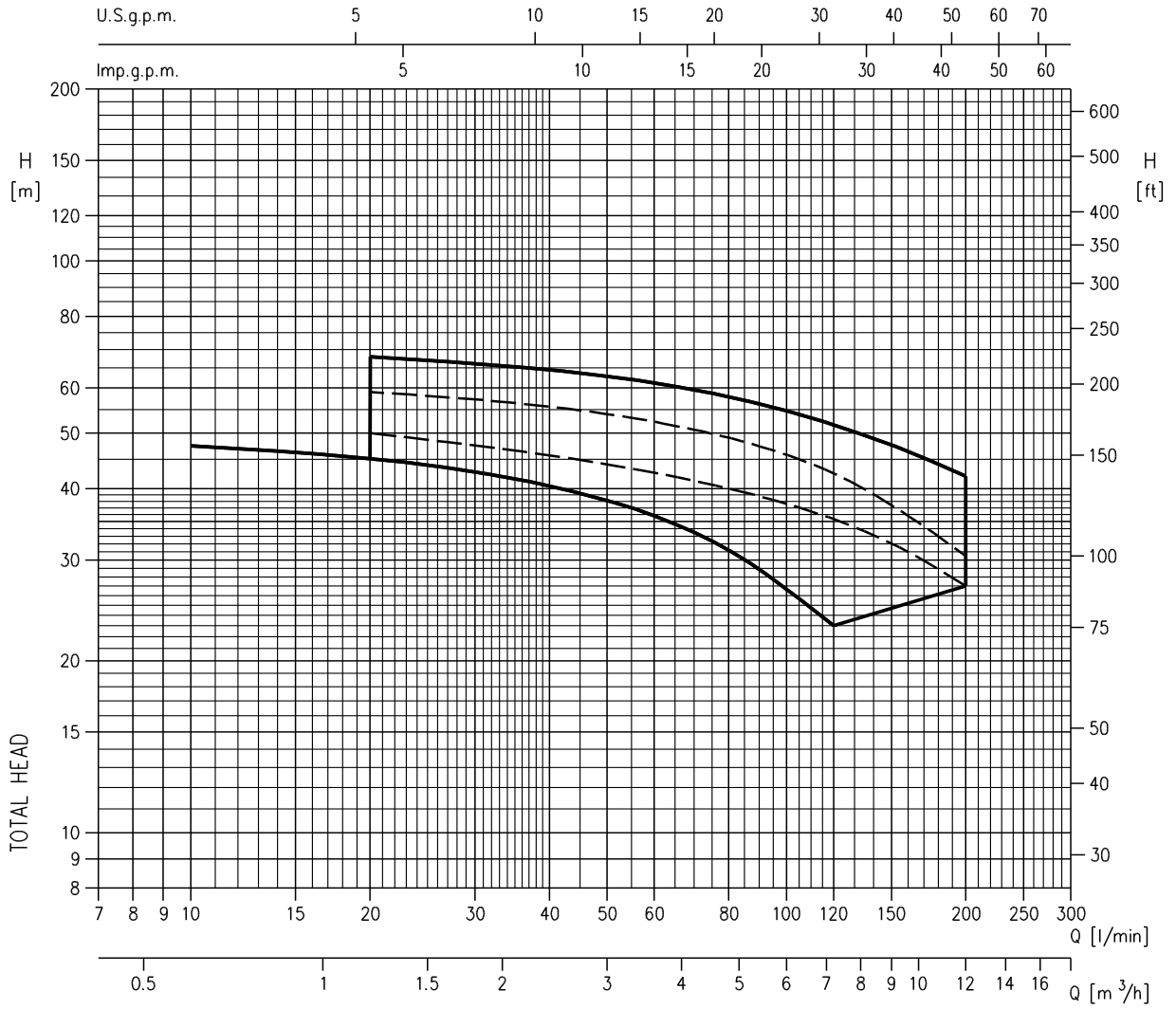

INTENTIONALLY EMPTY PAGE



**CURVE SPECIFICATION 2GP**

The specifications below qualify the curves shown on the following pages.

Tolerances according to ISO 9906 Annex A

The curves refer to effective speed of asynchronous motors at 50 Hz

Measurements were carried out with clean water at 20°C of temperature and with a kinematic viscosity of  $\nu = 1 \text{ mm}^2/\text{s}$  (1 cSt)

The NPSH curve is an average curve obtained in the same conditions of performance curves.

The continuous curves indicate the recommended working range. The dotted curve is only a guide.

In order to avoid the risk of over-heating, the pumps should not be used at a flow rate below 10% of best efficiency point.

Symbols explanation:

Q = volume flow rate

H = total head

P2 = pump power input (shaft power)

$\eta$  = pump efficiency

NPSH = net positive suction head required by the pump

## SELECTION CHART 2GP AGA

Model	Supply		Motor		Maximum working pressure (MPa)	Q=Capacity												
	Single phase	Three phase	kW	HP		l/min	0	10	20	40	60	90	100	120	160	200	260	320
						m <sup>3</sup> /h	0	0.6	1.2	2.4	3.6	5.4	6.0	7.2	9.6	12.0	15.6	19.2
						H=Total manometric head in meters												
2GP AGA 1.00(M)	•	•	0.75+0.75	1+1	0.8	50.0	47.5	45.0	40.3	35.7	29.1	27.0	23.0	-	-	-	-	-
2GP AGA 1.50(M)	•	•	1.1+1.1	1.5+1.5		51.0	-	48.0	45.1	42.4	38.6	37.4	35.1	30.8	27.0	-	-	-
2GP AGA 2.00(M)	•	•	1.5+1.5	2+2		62.5	-	59.0	55.6	52.2	47.3	45.7	42.5	36.4	30.5	-	-	-
2GP AGA 3.00	-	•	2.2+2.2	3+3		72.0	-	68.0	64.3	60.8	55.9	54.4	51.6	46.4	42.0	-	-	-

• : Standard    ○ : On request

### PERFORMANCE CURVE 2GP 2GP AGA 1.00(M)

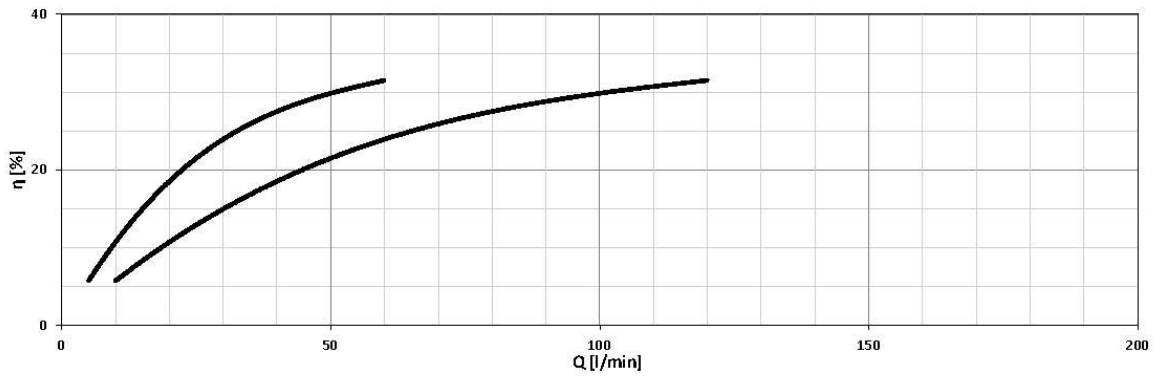
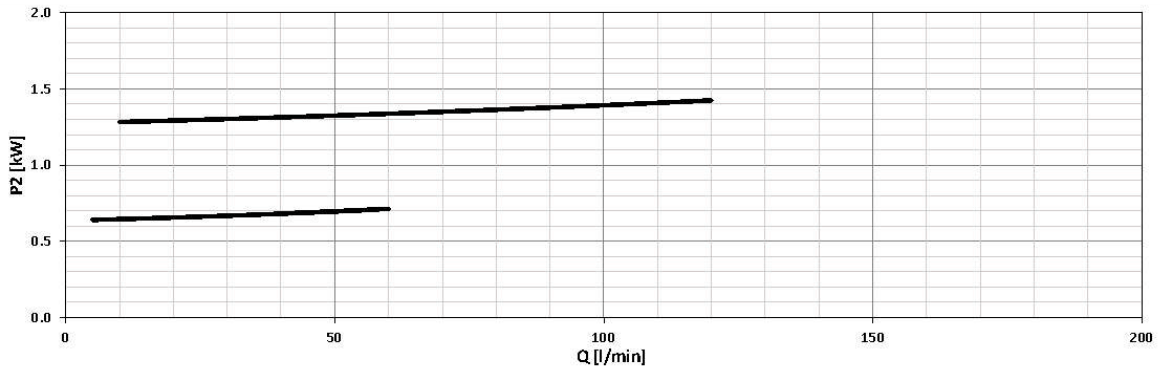
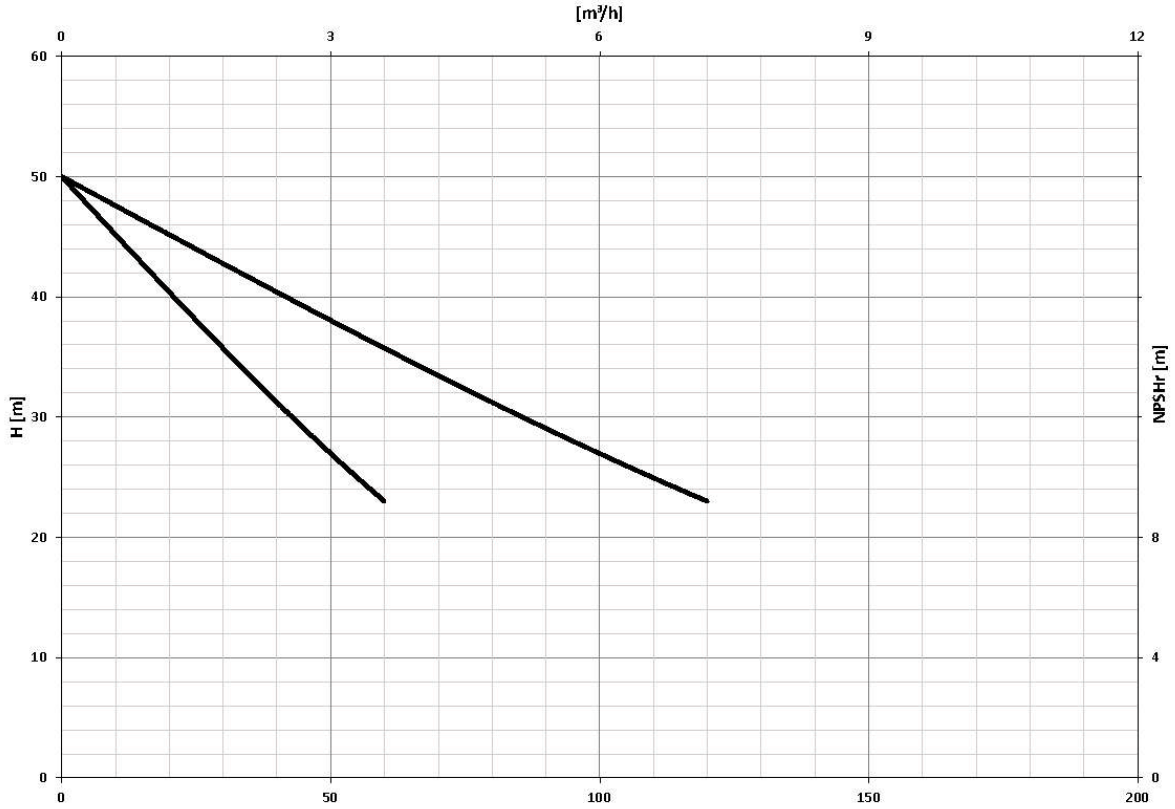

2GP AGA 1.50(M)

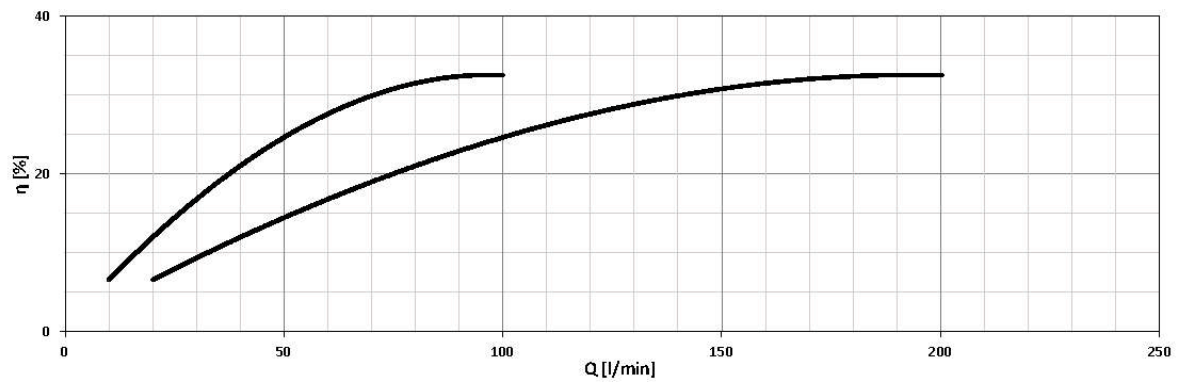
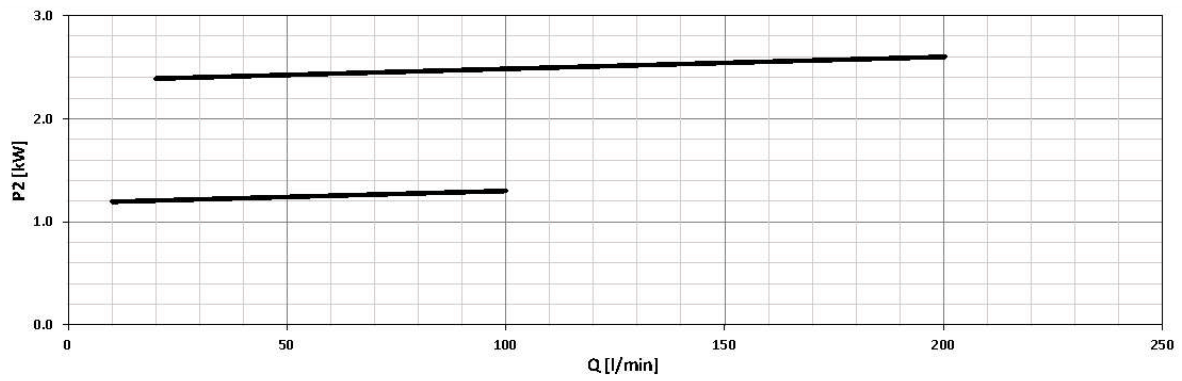
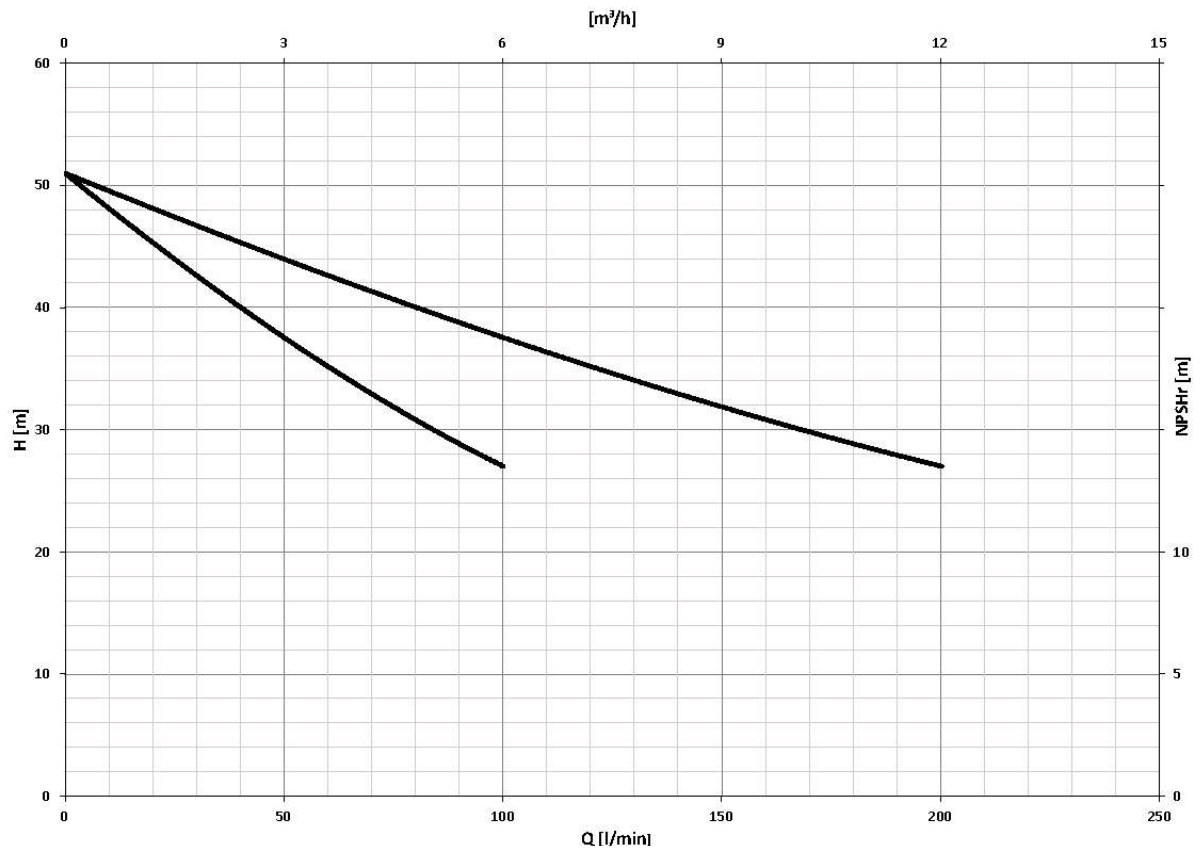

### 2GP AGA 2.00(M)

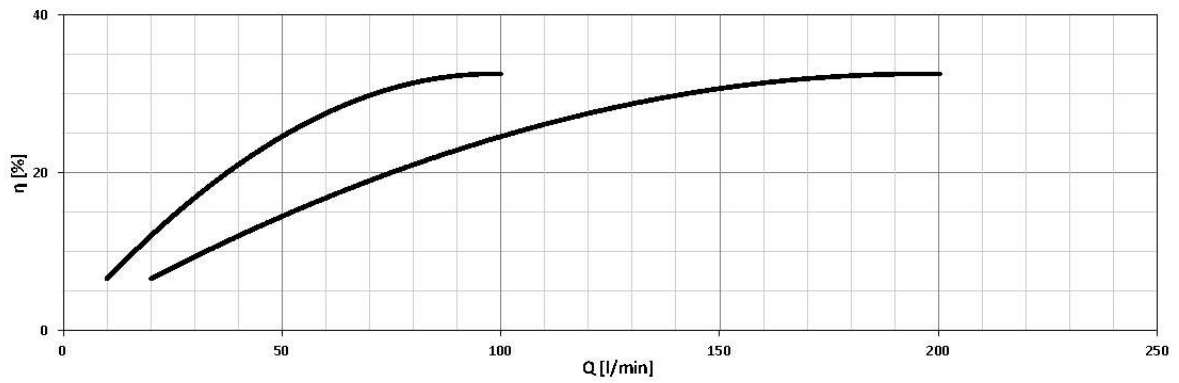
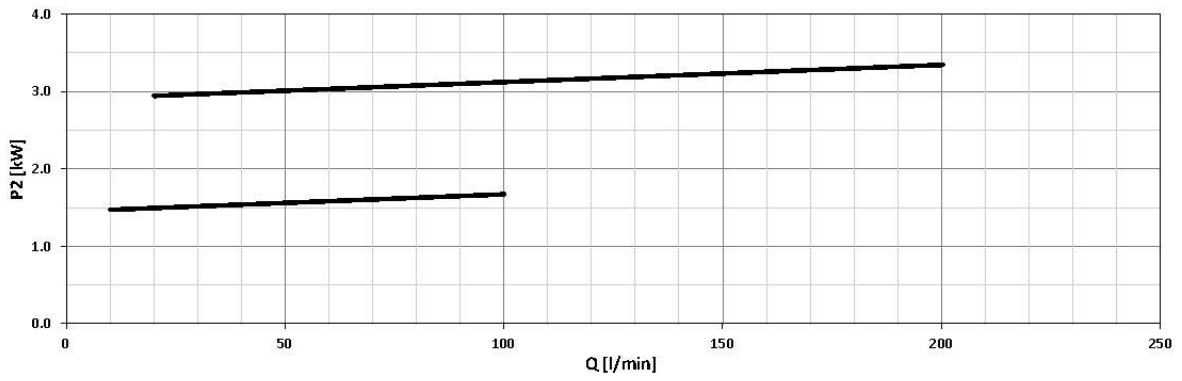
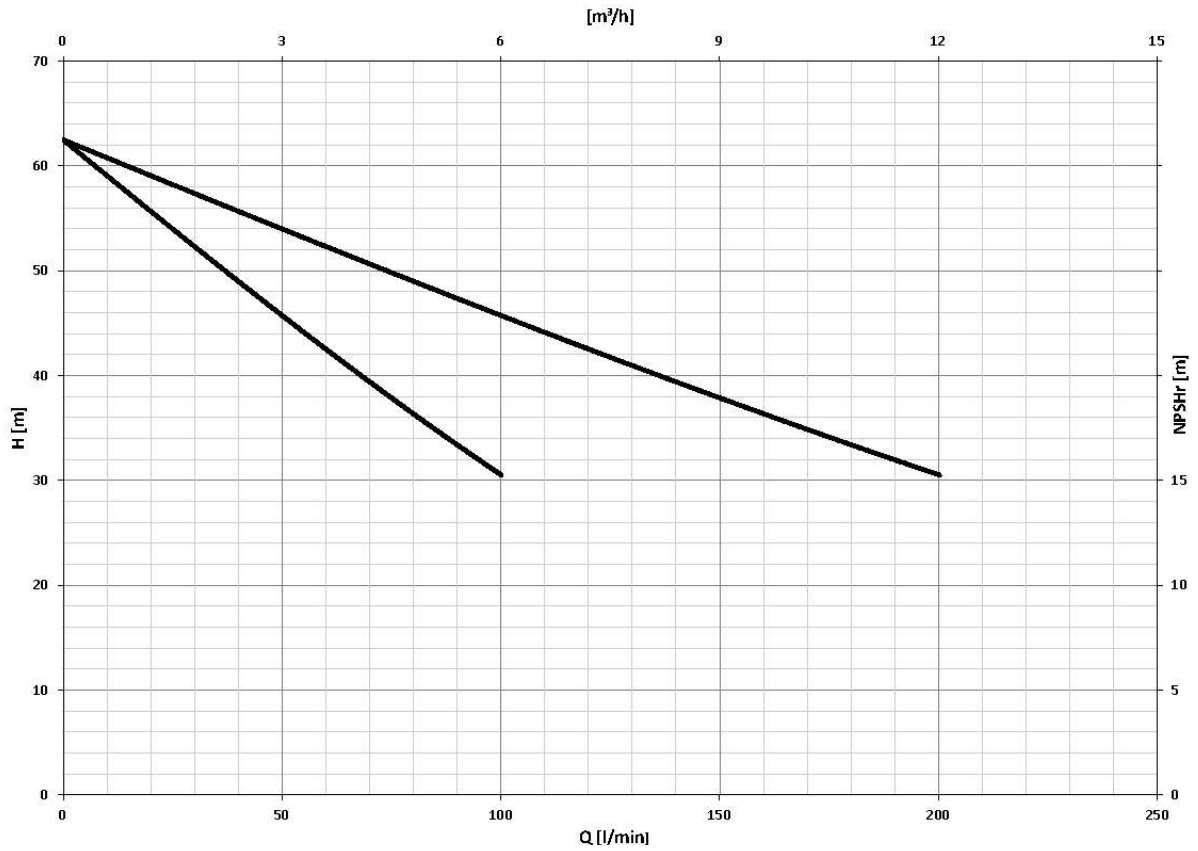

2GP AGA 3.00

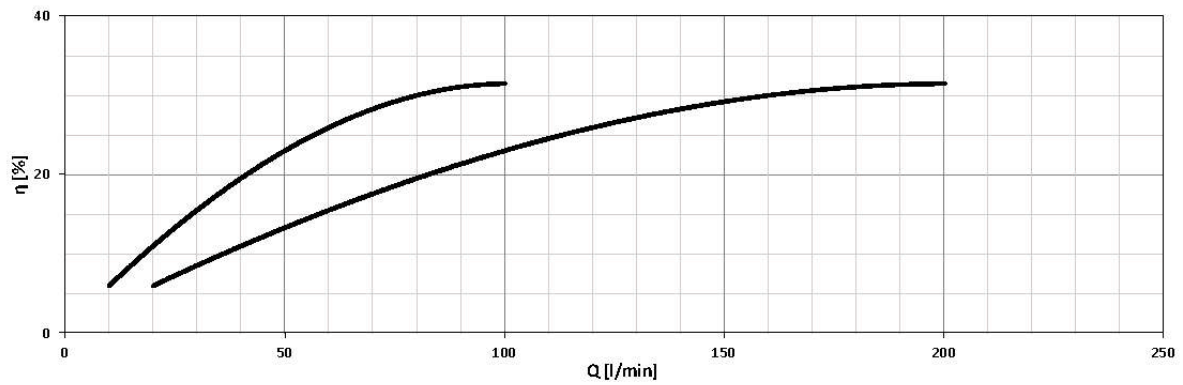
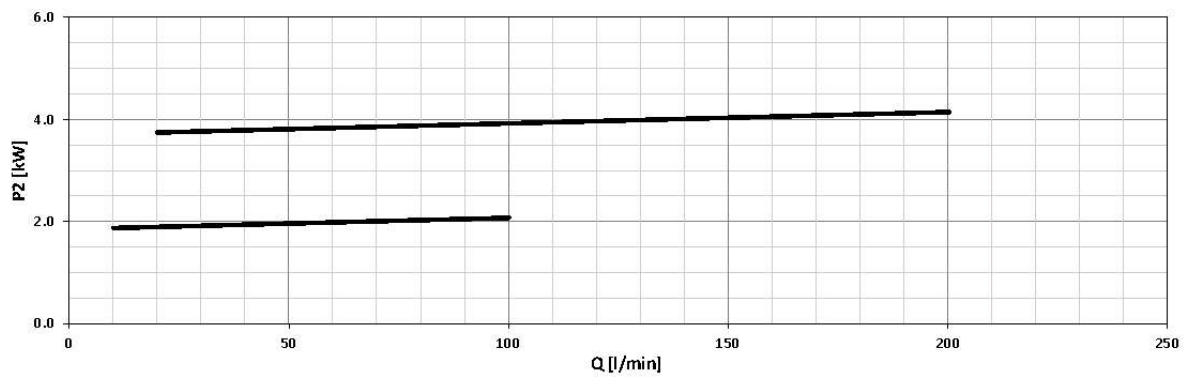
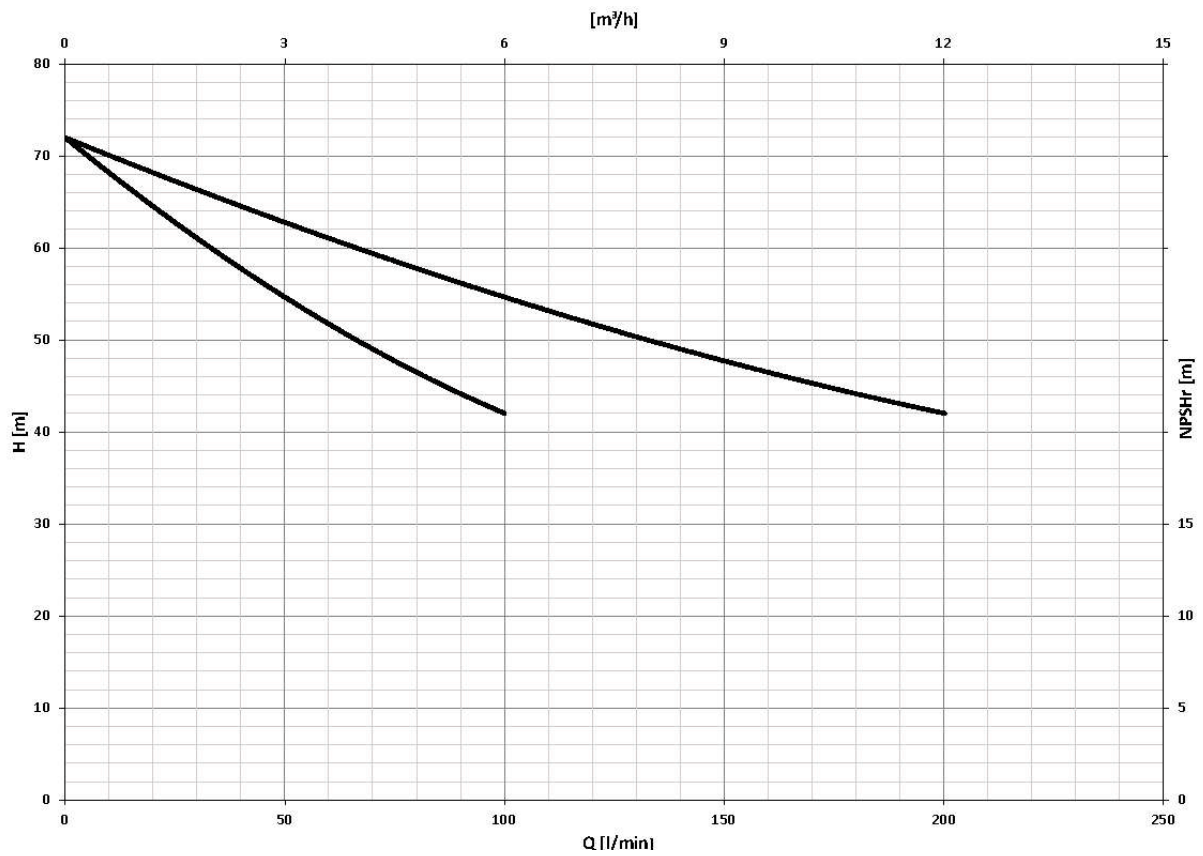

406

### 2GP CONSTRUCTION EXTERNAL VIEW 2GP AGA 1.00-1.50-2.00

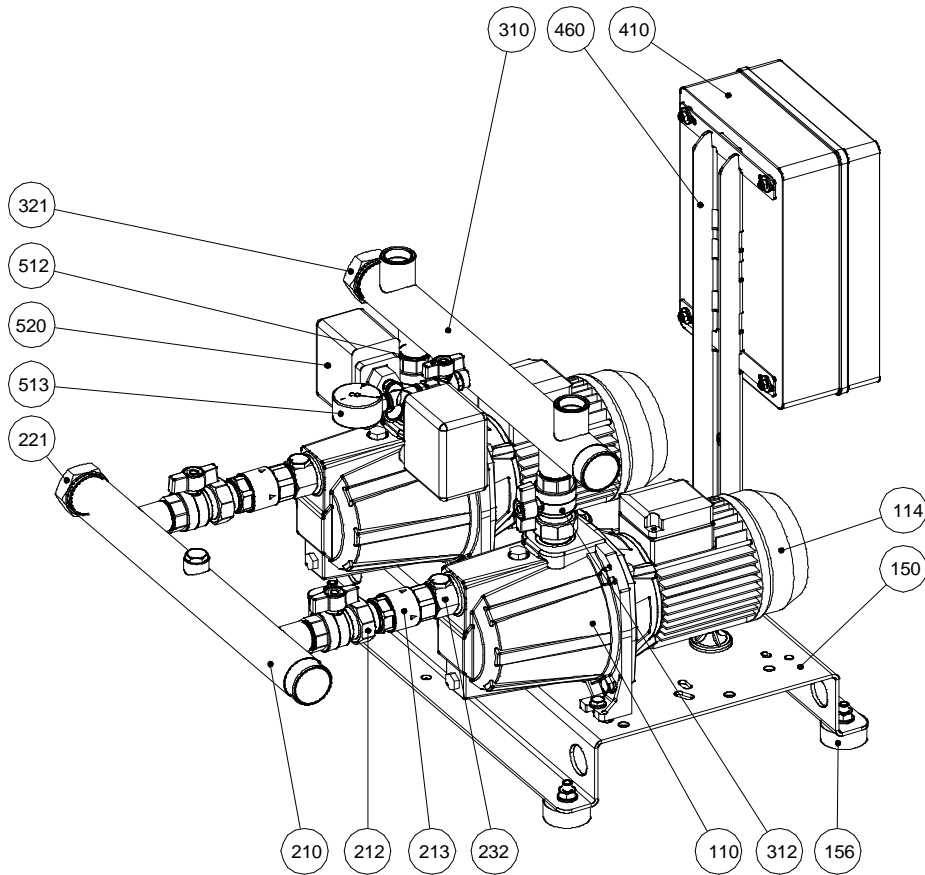

N°	PART NAME	MATERIAL	Quantity
110	Principal pump	-	2
114	Electric motor	-	2
150	Basement	Galvanized steel	1
156	Basement foot	SBR	4
210	Suction manifold	Galvanized steel	1
212	Union ball valve	CW617N / CW614N	2
213	Check valve	Brass / NBR	2
221	Threaded female cap	Galvanized steel	1
232	Nipple for air feeders	Yellow brass	2
310	Discharge manifold	Galvanized steel	1
312	Union ball valve	CW617N / CW614N	2
321	Female cap	Galvanized steel	1
410	Control panel	-	1
460	Control panel frame	Galvanized steel	1
512	Ball valve	CW617N / CW614N	1
513	Pressure gauge	Copper alloy / plastic	1
520	Pressure switches	-	2

601

## EXTERNAL VIEW 2GP AGA 3.00

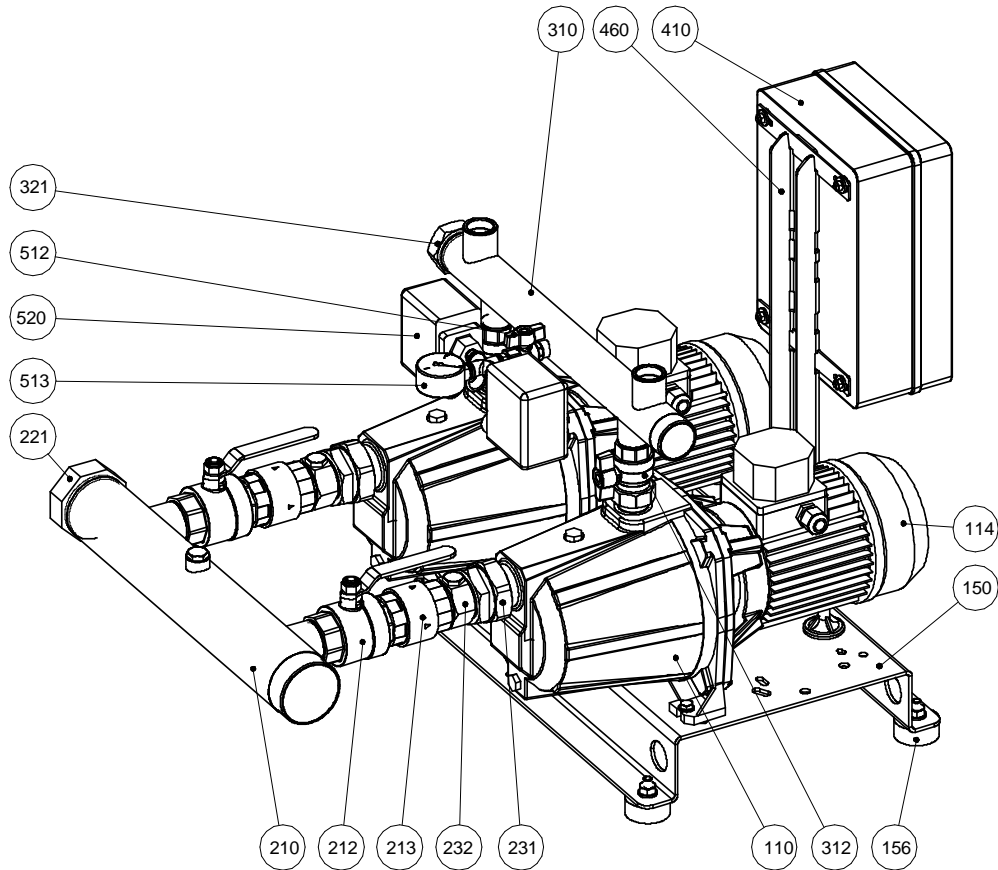

N°	PART NAME	MATERIAL	Quantity
110	Principal pump	-	2
114	Electric motor	-	2
150	Basement	Galvanized steel	1
156	Basement foot	SBR	4
210	Suction manifold	Galvanized steel	1
212	Ball valve	CW617N / CW614N	2
213	Check valve	Brass / NBR	2
221	Threaded female cap	Galvanized steel	1
231	Union 3 pcs.	Yellow brass	2
232	Nipple for air feeders	Yellow brass	2
310	Discharge manifold	Galvanized steel	1
312	Union ball valve	CW617N / CW614N	2
321	Female cap	Galvanized steel	1
410	Control panel	-	1
460	Control panel frame	Galvanized steel	1
513	Pressure gauge	Copper alloy / plastic	1
520	Pressure switches	-	2

602

EBARA Pumps Europe

EBARA Pumps Europe reserves the right to make changes without prior notice





### OVERALL DIMENSIONS 2GP BOOSTER SET 2GP AGA

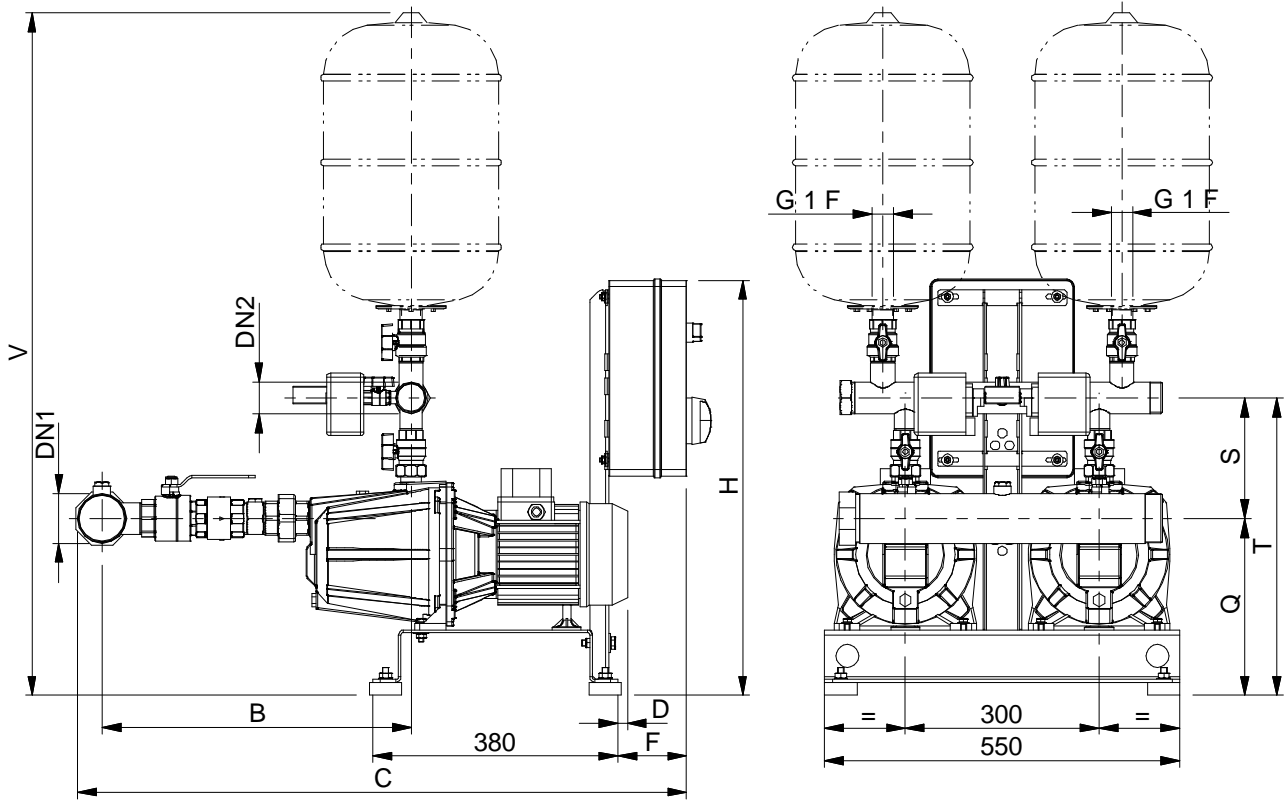

DIMENSIONS AND WEIGHT

Booster Type	Dimensions [mm]												Weight [kg]						
	DN1	DN2	B	1~ C	3~ 800	1~ D	3~ 45	75	105	1~ F	3~ 105	1~ H	3~ 635	Q	S	T	V	1~	3~
2GP AGA 1.00(M)	G 1 1/2	G 1 1/2	355	770	800	-	-	75	105	630	635	250	165	415	1005	58	62		
2GP AGA 1.50(M)	G 2 1/2	G 1 1/2	480	915	945	15	45	75	105	630	635	270	185	455	1045	85	89		
2GP AGA 2.00(M)	G 2 1/2	G 1 1/2	480	915	945	15	45	75	105	630	635	270	185	455	1045	87	93		
2GP AGA 3.00	G 2 1/2	G 1 1/2	480	-	945	-	45	-	105	-	635	270	185	455	1045	-	96		

701

PACKING

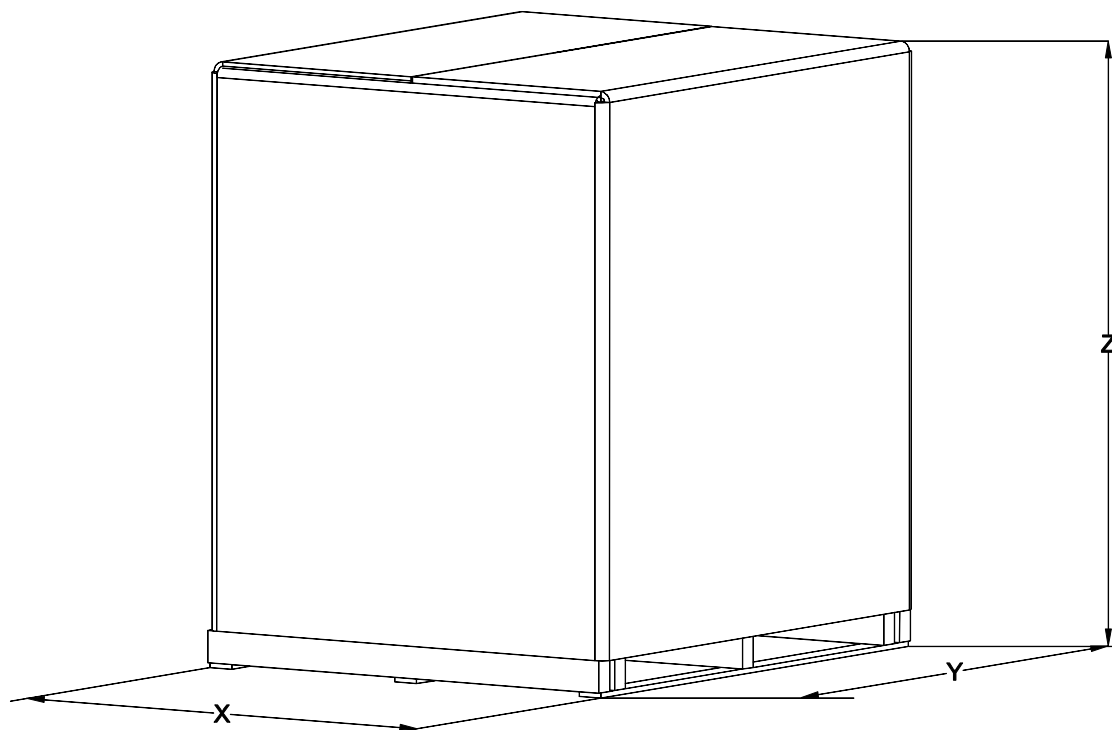

	Booster type	Overall dimensions packing			Booster+packing Weight [kg]
		X	Y	Z	
2GP	2GP AGA 1.00(M)	830	1230	1365	87
	2GP AGA 1.50(M)				114
	2GP AGA 2.00(M)				118
	2GP AGA 3.00				121

### CONTROL PANEL FIXED SPEED 2EP SPECIFICATION

- **SERIES 2EP M UA (single-phase power output)**
- **SERIES 2EP T UA (three-phase power output)**

Electrical panel (protection and control) for two electropumps. Manual or automatic operation through pressure switches or floats. The panel is configured to start the two pumps alternately in stand-by to pressure switch / float switch enable signals. The electrical panel protects the motors against overload and phase failure. Any protection devices that intervene are signalled on the panel itself and remotely through no voltage contacts. The protection device against overload and phase failure resets automatically three times, and manually after the fourth intervention (any interventions, from 1 to 3, are cancelled one hour after the last intervention).

#### TECHNICAL FEATURES

- P.MIN= Operation against dry running (tripped by a level float or minimum pressure switch) with automaticreset once water supply is restored, with warning lamp.
- PR1= Pump n. 1 start/stop
- PR2= Pump n. 2 start/stop
- Automatic start sequence alternation
- Motor protection against overload with automatic reset for three times and manual reset the fourth time
- Motor line protection against short-circuits with fuses for motor startup
- Transformer and auxiliary circuit protection with fuses
- Remote signalling, through NC-NO no voltage contact, of the protection devices that intervene

Version		2EP M UA	2EP T UA
Power source	Frequency	50/60 Hz	
	Phase	Single-phase	Three-phase
	Voltage	230 V ± 10%	400 V ± 10%
	Power	0.75 ÷ 1.5 kW	0.75 ÷ 2.2 kW
Others	Protection degree	IP 55	
	Ambient Temperature	-5°C + 40°C	
	Pressurisation units	2 pumps	
	Relative humidity	50% a 40°C MAX (90% a 20°C)	
	Max altitude	1000 m (a.s.l.)	
Directives	2014/35/EU (LVD), 2014/30/EU (EMC), 2011/65/EU (RoHS)		

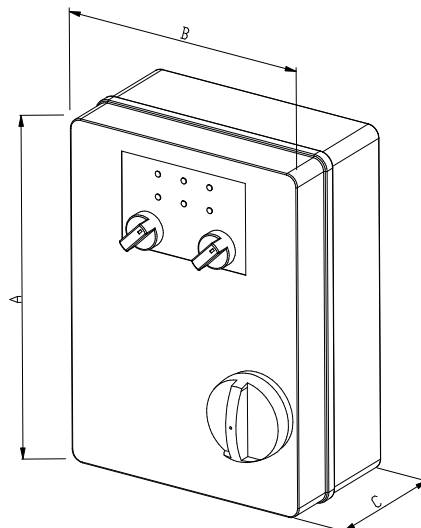

801

2 EP M UA MODELS TABLE

Model	Single pump Power [kW]	I Calibration [A]	Range Protection* [A]	Motor fuse	Dimensions AxBxC [mm]	Weight [kg]
2 EP 0,75 M	0,75	2x7	1÷12	8A aM (10.3x38)	240 x 190 x 90	1,5
2 EP 1,1 M	1,1	2x9	1÷12	10A aM (10.3x38)	240 x 190 x 90	1,5
2 EP 1,5 M	1,5	2x12	1÷12	12A aM (10.3x38)	240 x 190 x 90	1,5

\* Unipolar amperometric protection.

2 EP T UA MODELS TABLE

Model	Single pump Power [kW]	I Calibration [A]	Range Protection* [A]	Motor fuse	Dimensions AxBxC [mm]	Weight [kg]
2 EP 0,75 T	0,75	2x2	1÷12	6A am (10.3x38)	300 x 220 x 120	3,5
2 EP 1,1 T	1,1	2x3	1÷12	6A am (10.3x38)	300 x 220 x 120	3,5
2 EP 1,5 T	1,5	2x4	1÷12	8A am (10.3x38)	300 x 220 x 120	3,5
2 EP 2,2 T	2,2	2x6	1÷12	12A am (10.3x38)	300 x 220 x 120	3,5

\* Electronic amperometric protection (measured current on one phase).

Notes: Standard Control panels EP three-phase are available for 1, 2, 3 pumps until 30kW power  
For 4 or more pumps or power above 30kW are available on request

802



**EBARA Pumps Europe S.p.A.**

Via Pacinotti, 32  
36040 Brendola (Vicenza), Italia  
Phone +39 0444 706811  
Fax +39 0444 405811  
ebara\_pumps@ebaraeurope.com  
www.ebaraeurope.com

**EBARA Corporation**

11-1, Haneda Asahi-cho, Ohta-ku,  
Tokyo 144-8510  
Japan  
Phone +81 3 6275 7598  
Fax +81 3 5736 3193  
www.ebara.com

