

- A – Mating Ring
- B – Primary Ring
- C – Gland Adapter
- D – Gland Plate
- E – Collar
- F – Sleeve

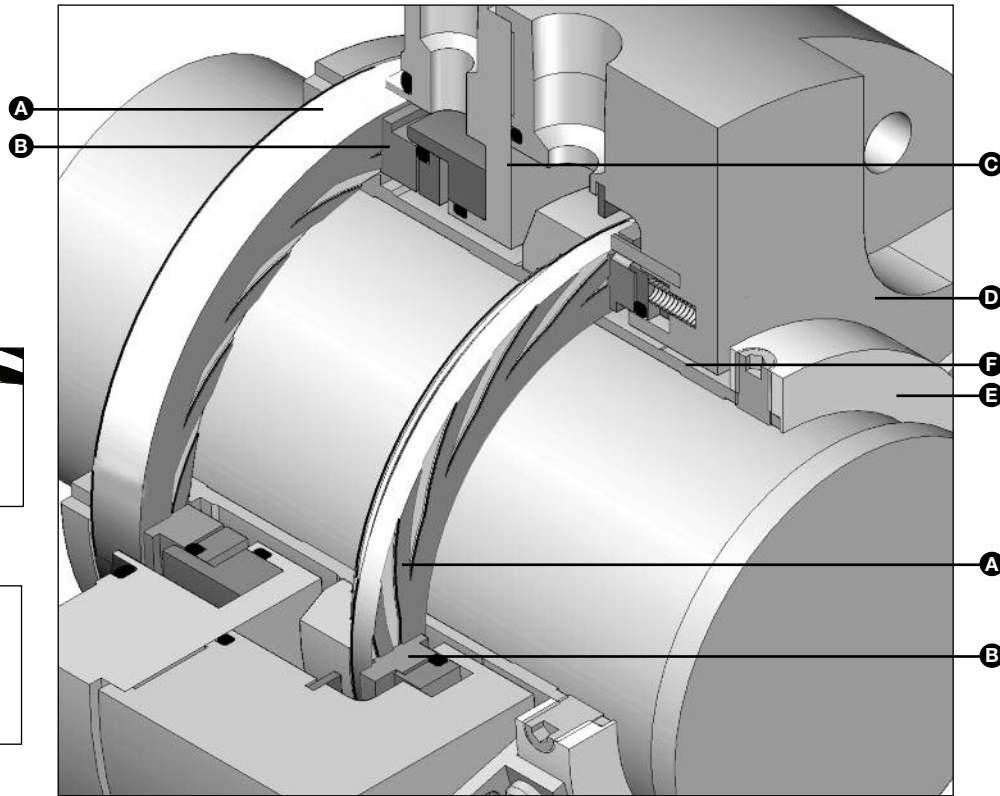

Outward Pumping
Spiral Grooves



Featuring John Crane's
Centrifugal Advantage

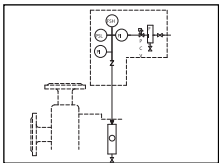

API 682/ISO 21049 3NC
Plan 74 Compliant

Product Description

- Non-contacting, internally pressurized outward pumping dual seal cartridge for new and existing pumps
- For Maximum Achievable Control Technology (MACT) and high reliability sealing of volatile or hazardous fluids in chemical, petrochemical and refining processes
- For process fluids that display turbidity or solids in suspension.
- For sealing high purity fluids without potential for product contamination
- For sealing fluids that are sensitive to thermal gain or decay
- For use in API, ANSI and DIN large bore seal chambers

Design Features

- Inside diameter (ID) to outside diameter (OD) pumping spiral groove arrangement places process fluid at the OD of the inboard seal. Eliminates low flow regions in close proximity to inboard seal, reduces dewatering and hang up
- Rotating mating ring imparts centrifugal flow to fluid in the seal chamber of equipment
- 0.0 fugitive emissions
- Reverse pressure capability
- Simplified barrier gas support system

Performance Capabilities

- Temperature: -20°F to 500°F/-30°C to 260°C
- Pressure: vacuum to 600 psi(g) barrier pressure
- Speed: 1450 rpm minimum/3600 maximum
(For shaft speeds outside this range, contact John Crane.)
- Axial movement: +/-0.040"
- Runout: 0.002" TIR

Barrier Consumption

The Type 2874 uses inert barrier gas to lubricate the seal faces. The inboard seal is operated at a 30 to 50 psi(g) pressure differential and the outboard seal operates at full pressure differential. Therefore, it is estimated that 75 percent of total barrier consumption passes outboard into the atmosphere. The barrier consumption of the Type 2874 can be estimated by the user as one standard cubic foot of barrier gas per inch of shaft diameter, per hour, per 100 psi(g) of barrier pressure. More specific values are available from John Crane.

TYPE 2874

NON-CONTACTING, OUTWARD PUMPING DUAL GAS SEAL

Technical Specification

Type 2874 Typical Arrangement

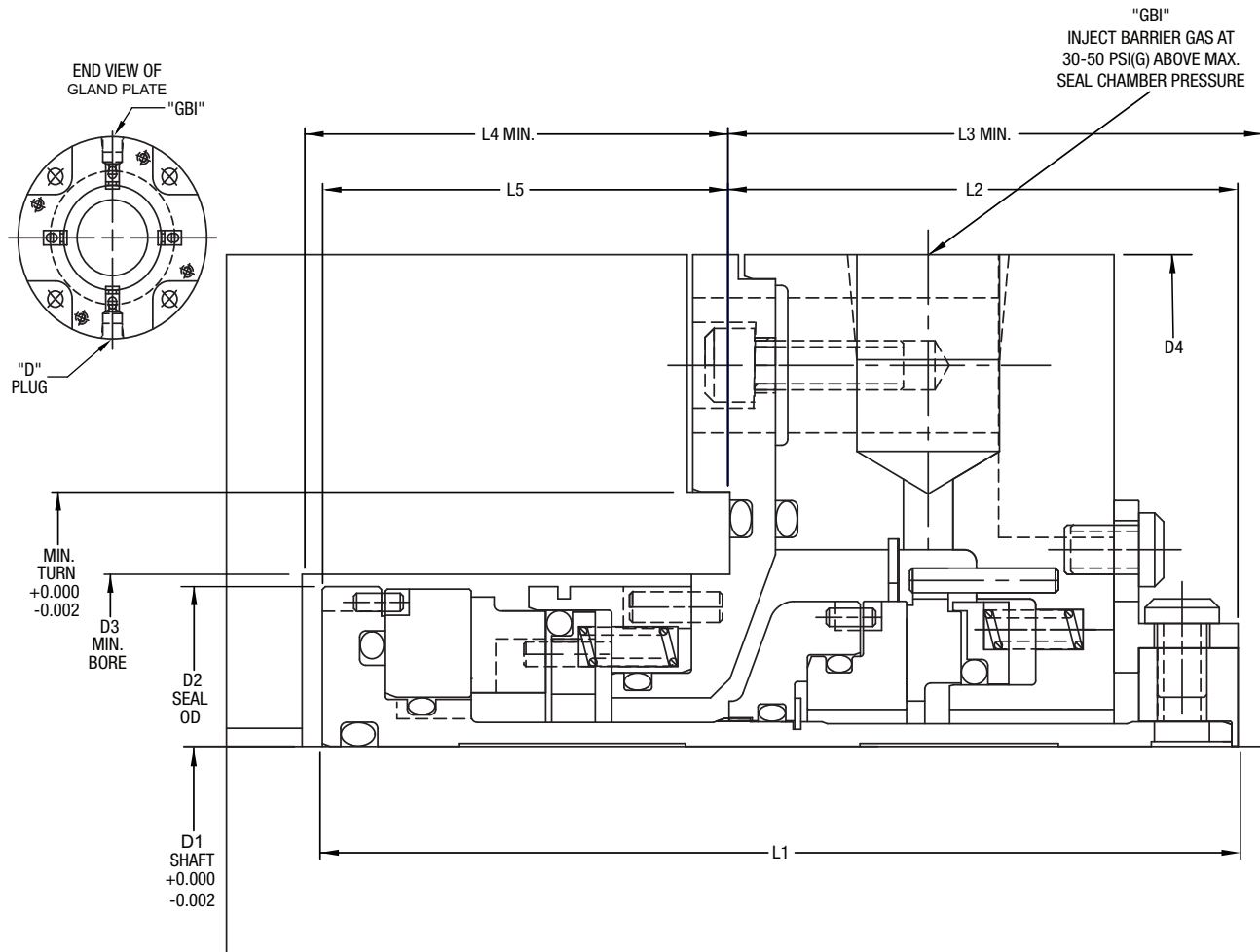

Type 2874 Dimensional Data (inches)

SEAL SIZE	D1	D2	D3 MIN.	D4	L1	L2	L3 MIN	L4 MIN.	L5	MIN. TURN DIA	MIN. STUD DIA.	STUD DBC	CW REF DRAWING	CCW REF. DRAWING
1.375*	1.375	2.821	2.875	5.375	4.125	2.125	2.187	2.062	2.000	3.597	0.375	4.500	HSP-1033467	HSP-1034130
1.375**	1.375	2.821	2.875	5.000	4.125	2.125	2.187	2.062	2.000	3.375	0.375	4.000	HSP-1033468	HSP-1034131
1.500	1.500	3.125	3.375	6.000	5.000	3.125	3.250	2.000	1.875	3.625	0.500	5.000	HSP-1033469	HSP-1034132
1.750	1.750	3.375	3.500	6.500	4.769	2.726	2.812	2.125	2.042	4.340	0.500	5.500	HSP-1033470	HSP-1034133
1.875	1.875	3.500	3.625	5.875	4.769	3.018	3.218	1.875	1.750	4.125	0.500	5.000	HSP-1033471	HSP-1034134
2.000	2.000	3.932	3.937	6.625	5.000	3.600	3.725	1.937	1.875	4.500	0.625	5.500	HSP-1033472	HSP-1034135
2.125	2.125	3.750	3.875	7.125	4.617	2.562	2.687	2.156	2.054	4.711	0.625	6.000	HSP-1033473	HSP-1034136
2.250	2.250	3.875	4.120	8.250	5.000	3.375	3.500	1.750	1.625	4.750	0.750	6.500	HSP-1033474	HSP-1034137
2.500	2.500	4.125	4.500	7.875	4.617	2.116	2.187	2.562	2.500	5.455	0.625	6.750	HSP-1033475	HSP-1034138
2.625	2.625	4.250	4.625	7.000	4.617	2.116	2.187	2.608	2.500	5.125	0.500	6.000	HSP-1033476	HSP-1034139
2.750	2.750	4.375	4.750	7.875	4.769	2.484	2.609	2.500	2.284	5.455	0.625	6.750	HSP-1033477	HSP-1034140
3.000	3.000	4.625	5.000	8.500	5.000	2.905	3.030	2.937	2.095	5.625	0.750	7.250	HSP-1033478	HSP-1034141
3.250	3.250	4.875	5.000	8.000	5.000	2.875	3.000	3.156	2.125	5.500	0.625	6.625	HSP-1033479	HSP-1034142
3.375	3.375	5.000	5.875	9.500	5.000	3.000	3.609	2.546	2.000	6.375	0.875	8.000	HSP-1033480	HSP-1034143
3.500	3.500	5.125	6.000	9.000	5.000	3.968	4.093	1.937	1.032	6.500	0.625	7.750	HSP-1033481	HSP-1034144
4.000	4.000	5.625	6.500	10.000	5.000	3.000	3.345	2.757	2.000	7.000	0.500	8.250	HSP-1033482	HSP-1034145

*Goulds 3196 ST Big Bore
 ** Duriron Mark III Group IK

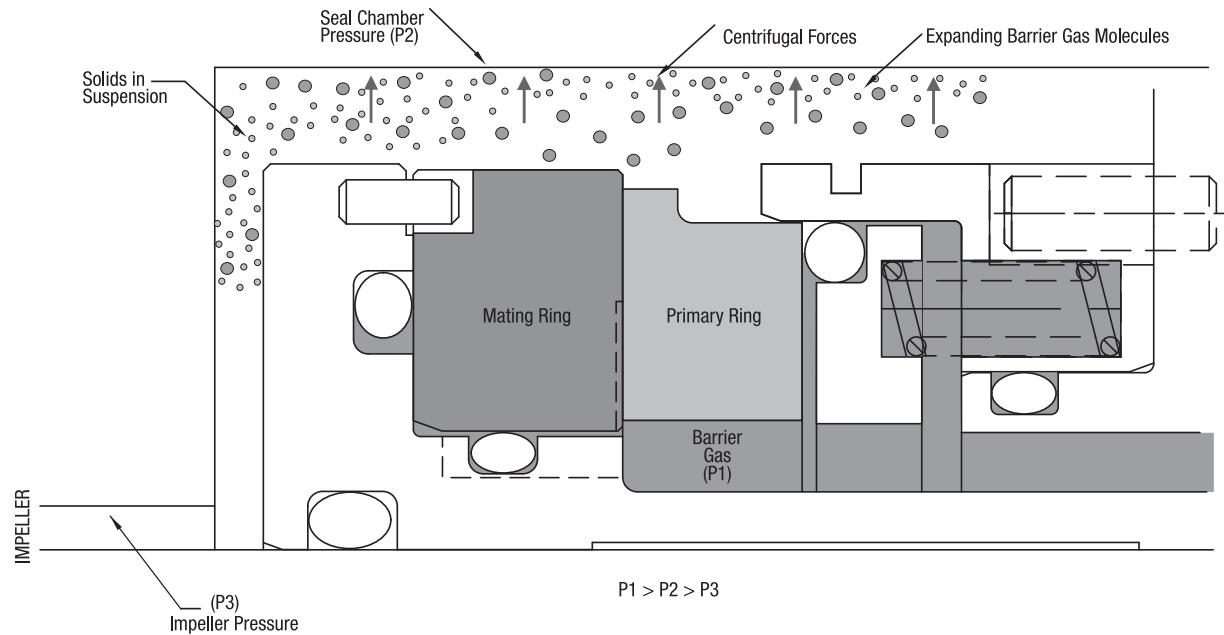
Non-Contacting ID to OD Barrier Pumping Spiral Grooves

The Type 2874 uses unique spiral groove technology developed and patented by John Crane. The inboard mating ring of the Type 2874 features micro machined spiral grooves. The inboard carbon primary ring seals against an un-grooved sealing dam of the mating ring. The face pair is pressurized on the inside diameter to a pressure differential of 20 to 30 psi(g). When the pump shaft turns, spiral grooves compress the pressurized barrier gas and create a lifting force on the primary ring. The result is non-contacting operation. With barrier gas at the ID of the face pair, the spiral grooves are designed to pump gas to the OD. The stiff ring of compressed barrier gas exiting the face pair creates a highly effective dry seal. ID to OD barrier gas pumping exposes the inboard seal to a relatively large volume of liquid. This reduces dewatering/drying affects of exiting barrier gas and results in a more tolerant, durable seal particularly where high solids fluids are sealed.

The Type 2874 features reverse pressure capability. In the event of a pressure reversal where seal chamber pressure exceeds barrier gas pressure, the secondary seal shifts closing the inboard seal and preventing product release.

The outboard seal faces handling full differential pressure, use conventional OD to ID pumping spiral grooves. When the pump shaft rotates, spiral grooves compress barrier gas and create a lifting force resulting in non-contacting operation. The outboard seal pumps inert barrier gas into the atmosphere.

Rotating Mating Ring Advantage

Historically a sleeve mounted rotating mating ring is chosen because of its advantage where the gland plate and shaft have lost perpendicular alignment. In this arrangement, the flexible element of the seal (the stationary primary ring) can deflect to a fixed position to match the rotating face. In an arrangement that features a rotating flexible member, the primary ring would flex and change position once per shaft revolution to accommodate the out of square stationary face. The rotating mating ring arrangement offers significant benefits that add to the durability of the Type 2874. Seal chamber face runout to shaft can be a maximum of .002" TIR for the Type 2874 standard size range. For larger seals contact John Crane.

TYPE 2874

NON-CONTACTING, OUTWARD PUMPING DUAL GAS SEAL

Technical Specification

Type 2874 Components

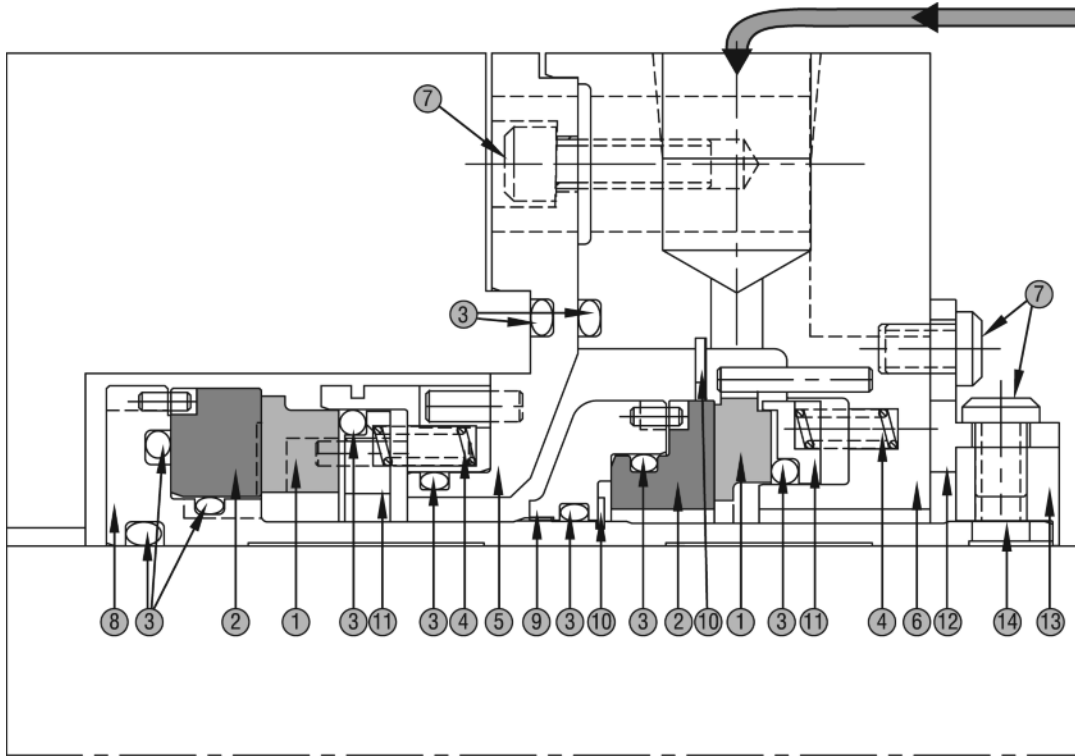

Materials of Construction

SEAL COMPONENTS	MATERIALS	
Description	Standard	Options
1 - Primary Ring	Carbon	—
2 - Mating Ring	Tungsten Carbide	Silicon Carbide
3 - O-rings	Fluoroelastomer	Perfluoroelastomer
4 - Spring	Alloy C-276	—
5 - Gland Adapter	316 SS	Alloy C-276 (UNS N10276), Alloy B-2
6 - Gland Plate	316 SS	Alloy C-276 (UNS N10276), Alloy B-2
7 - Cap Screw	316 SS	Alloy C-276 (UNS N10276), Alloy B-2
8 - Sleeve	316 SS	Alloy C-276 (UNS N10276), Alloy B-2
9 - Mating Ring Adapter	316 SS	Alloy C-276 (UNS N10276), Alloy B-2
10 - Snap Ring	18-8 SS	—
11 - Disc	316 SS	—
12 - Spacer	Plated Steel	—
13 - Collar	316 SS	—
14 - Set Screw	Hardened Steel	Alloy C-276 (UNS N10276), Alloy B-2

Type 2874 Gas Control Panel

STANDARD COMPONENTS

- 1 - Isolating Ball Valve - 316 SS
- 2 - Coalescing Filter - 316 SS
- 3 - Pressure Regulator - 316 SS
(low pressure option Aluminum)
- 4 - Gauge - Phenolic/316 SS
- 5 - Flow Indicator - Low Range
- 6 - Flow Indicator - High Range
- 7 - Pressure Switch (optional)
15A 125/240/480 (SPDT)
- 8 - Check Valve - 316 SS
(Viton optional elastomers)
- 9 - Connection to Seal
- 10 - Back Panel - 304 SS

Note: Engineered gas panels can be configured to customer requirements.

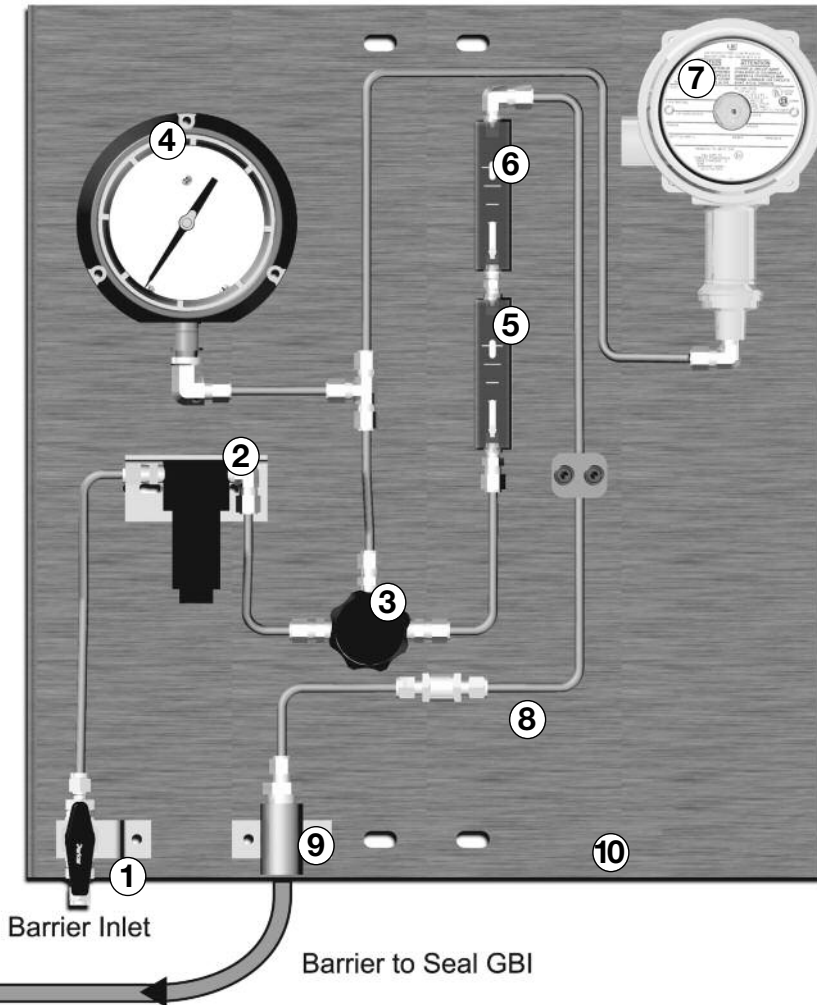

- In a double seal arrangement inert gas (normally nitrogen) is supplied to the seal and maintained at a pressure higher than the seal chamber pressure. Standard instruments and controls have been arranged to deliver clean dry barrier gas at a pressure specified by the operator. Elements of the control panel are connected via 1/4" OD x 0.035" wall 316 SS seamless tubing.
- The coalescing filter is intended to remove moisture and contaminants from the barrier gas supply. Use of the filter will deliver clean dry nitrogen to the seal filtered to 0.3 – 0.6 micron nominal.
 - The pressure regulator is used to set barrier pressure on the seal cartridge at 30 to 50 psi(g) above seal chamber pressure.
 - The pressure gauge is a 4.5" diameter analog face and will indicate the pressure provided to the mechanical seal.
 - Rotometers are intended to indicate flow. They are not intended to be a precise measure of barrier consumption. John Crane can provide empirical barrier consumption data upon request.
 - The pressure switch is intended to indicate loss of barrier pressure and provide an output signal.
 - Downstream of the pressure switch, barrier gas flows through a one way check valve. The check valve has a 1/3 psi(g) cracking pressure and protects the gas panel and nitrogen system from reverse flow.
 - Instrumentation is mounted to a 304SS panel as standard and NEMA enclosures are available. Instrumentation can be augmented to deliver specific information. Contact John Crane for options.

Piping Options for Hot Standby Pumps

HOT BY-PASS FOR A STANDBY PUMP - OPTION 1

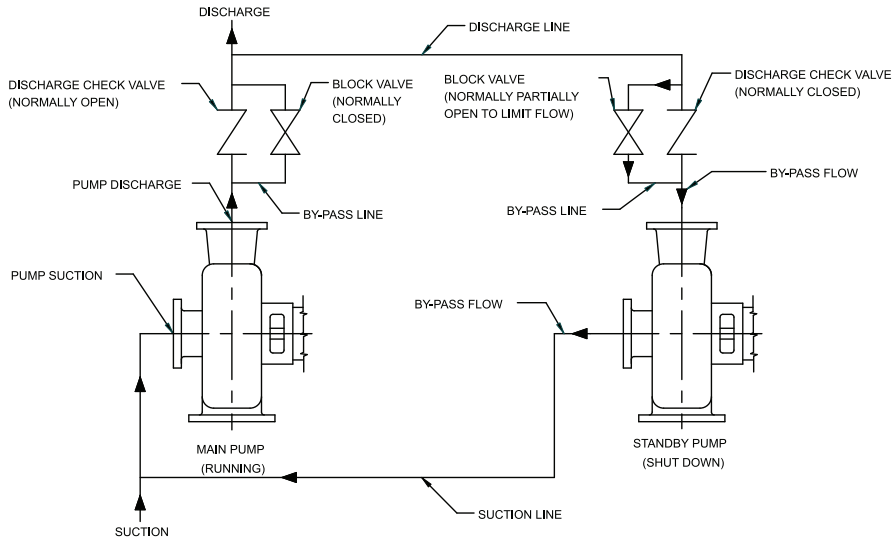

HOT BY-PASS FOR A STANDBY PUMP - OPTION 2

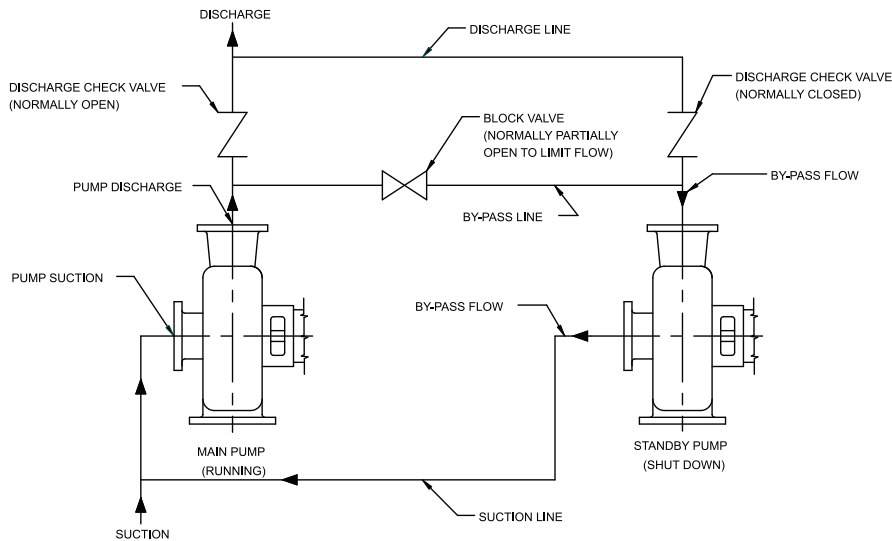

Often gas lubricated seals are installed on primary and standby pumps. Above are the recommended piping plans that allow standby pumps to manage barrier collection in static conditions. Both diagrams offer continuous circulation of pumped fluid in order to maintain temperature and avoid cavitation upon start-up of stand by equipment. Detailed information and recommendations for specific applications are available from John Crane.

john crane

TYPE 2874

NON-CONTACTING, OUTWARD PUMPING DUAL GAS SEAL

Technical Specification



North America
 United States of America
 Tel: 1-847-967-2400
 Fax: 1-847-967-3915

Europe
 United Kingdom
 Tel: 44-1753-224000
 Fax: 44-1753-224224

Latin America
 Brazil
 Tel: 55-11-3371-2500
 Fax: 55-11-3371-2599

Middle East & Africa
 United Arab Emirates
 Tel: 971-481-27800
 Fax: 971-488-62830

Asia Pacific
 Singapore
 Tel: 65-6518-1800
 Fax: 65-6518-1803

If the products featured will be used in a potentially dangerous and/or hazardous process, your John Crane representative should be consulted prior to their selection and use. In the interest of continuous development, John Crane Companies reserve the right to alter designs and specifications without prior notice. It is dangerous to smoke while handling products made from PTFE. Old and new PTFE products must not be incinerated. ISO 9001 and ISO14001 Certified, details available on request.