

- A – Primary Ring
- B – Mating Ring
- C – Compression Ring
- D – Sealing Ring
- E – Gland Plate
- F – Clamp Ring
- G – Drive Ring
- H – Fasteners
- I – Retaining Ring
- J – Cord Segment

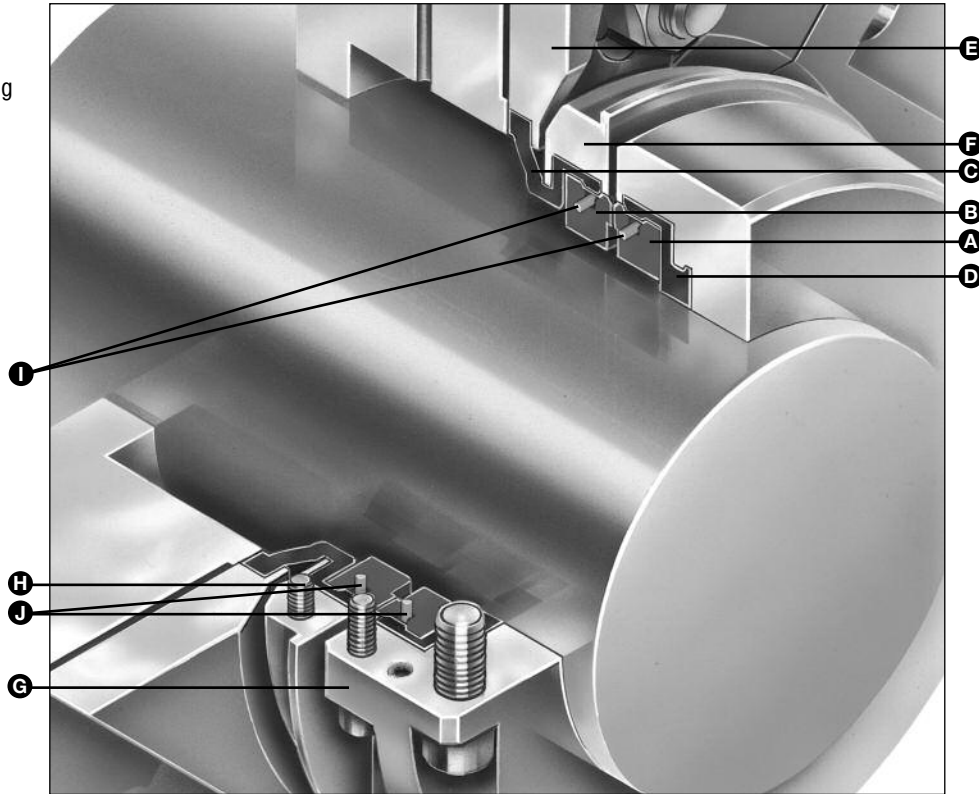

### Product Description

The Type 37FSB fully split seals contribute to significantly reduced maintenance on larger, difficult-to-seal equipment. They are recommended for use on heavy duty, packed equipment that previously could not accommodate mechanical seals because of severe shaft runout and vibration, difficulty to disassemble, worn out equipment, and similar problems. Type 37FSB seals are outside mounted and can be used on vertical and horizontal applications.

- For use on large, heavy duty rotating shaft equipment such as mixers, agitators, pumps
- For pulp and paper, power generation, food processing, wastewater treatment, mining, and other demanding industries

### Performance Capabilities

- Temperature: 82°C/180°F max.
- Pressure: 14 barg/200 psig max.
- Speed: 1800 rpm max.

For other operating conditions, consult John Crane.

### Design Features

- Compression ring provides extreme flexibility. Shaft deflections, angular misalignments, and run outs are “tracked” by the seal without diminishing performance
- Compression ring acts as the spring eliminating clogging problems seen in fibrous or abrasive services
- Long slots on gland plates allow the seals to be fitted to numerous pumps and other rotating equipment without adaptors
- The rotating assembly can be machined to fit any size shaft
- No O-rings - wide sealing surface of the sealing ring prevents leaks even on the most worn, pitted shafts.
- The rotating assembly self-aligns itself square with the shaft for true running
- Fewer parts and simple design allow for easy installation without the need for equipment modification
- Retaining ring ensures perfect face halves alignment and trouble-free startup

# TYPE 37FSB

## BALANCED FULLY SPLIT SEAL

### Type 37FSB Typical Arrangement

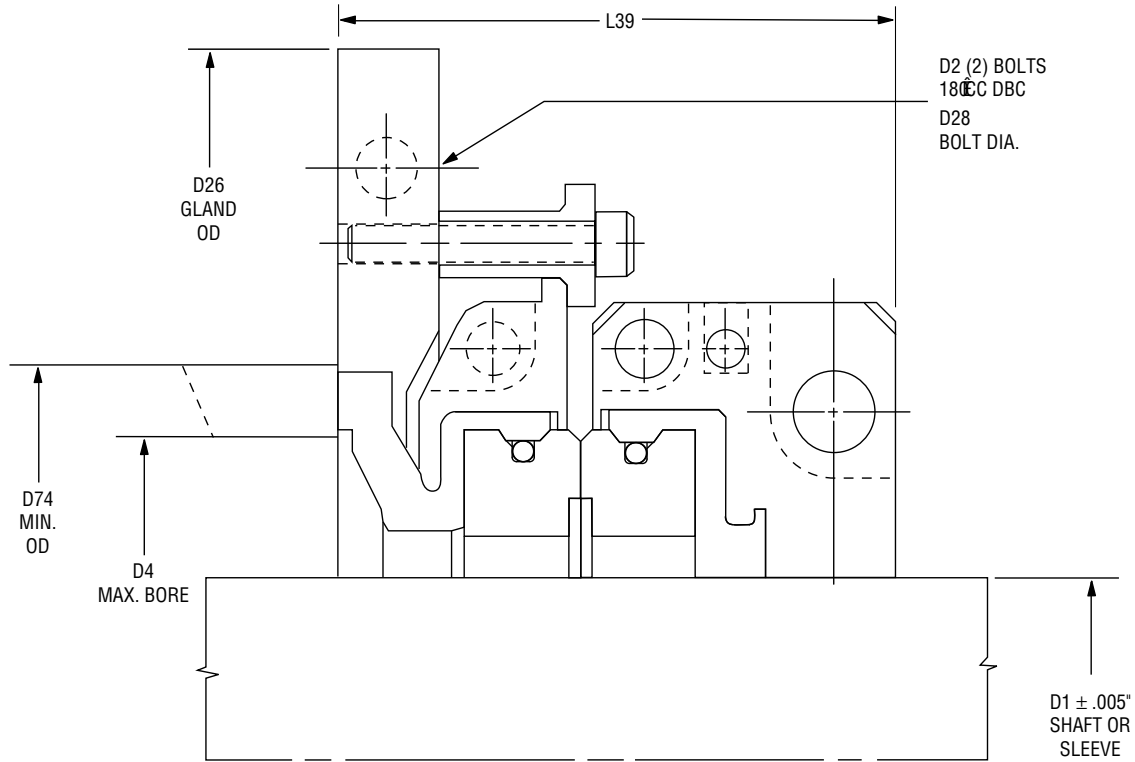

### Type 37FSB Dimensional Data (inches)

Shaft/ Sleeve Size D1	D2	D4	D26	D28	D74	SIC/SIC*	L39	CAR/SIC **
3.437-3.811	8.250-10.750	5.375	11.750	.750	6.182	3.42	3.48	3.48
3.812-4.186	8.625-11.125	5.750	12.125	.750	6.557	3.42	3.48	3.48
4.187-4.561	9.000-11.500	6.125	12.500	.750	6.932	3.42	3.48	3.48
4.562-4.936	9.375-11.875	6.500	12.875	.750	7.307	3.42	3.48	3.48
4.937-5.311	9.750-12.250	6.875	13.250	.750	7.682	3.42	3.48	3.48
5.312-5.686	10.125-12.625	7.250	13.625	.750	8.057	3.42	3.48	3.48
5.687-6.061	10.500-13.000	7.625	14.000	.750	8.432	3.42	3.48	3.48
6.062-6.436	10.875-13.375	8.000	14.375	1.000	8.807	3.63	3.69	3.69
6.437-6.811	11.250-13.750	8.375	14.750	1.000	9.182	3.63	3.69	3.69
6.812-7.186	11.625-14.125	8.750	15.125	1.000	9.557	3.63	3.69	3.69
7.187-7.561	12.000-14.500	9.125	15.500	1.000	9.932	3.63	3.69	3.69
7.562-7.936	12.375-14.875	9.500	15.875	1.000	10.307	3.63	3.69	3.69
7.937-8.311	12.750-15.250	9.875	16.250	1.000	10.682	3.63	3.69	3.69
8.312-8.686	13.125-15.625	10.250	16.625	1.000	11.057	3.63	3.69	3.69
8.687-9.061	13.500-16.000	10.625	17.000	1.000	11.432	3.63	3.69	3.69
9.062-9.436	13.875-16.375	11.000	17.375	1.000	11.807	3.63	3.69	3.69
9.437-9.811	14.250-16.750	11.375	17.750	1.000	12.182	3.63	3.69	3.69
9.812-10.187	14.625-17.125	11.750	18.125	1.000	12.557	3.63	3.69	3.69

\* SIC/SIC = Silicon Carbide vs. Silicon Carbide

\*\* CAR/SIC = Carbon vs. Silicon Carbide

# TYPE 37FSB

## BALANCED FULLY SPLIT SEAL

### Basic Pressure Rating

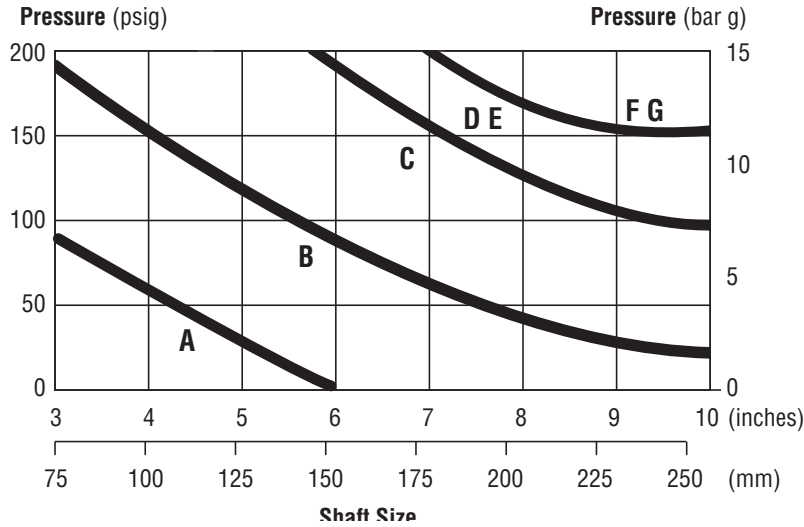

- A. Silicon Carbide vs. Silicon Carbide (Similar) 1800 rpm
- B. Silicon Carbide vs. Silicon Carbide (Similar) 1200 rpm
- C. Silicon Carbide vs. Silicon Carbide (Similar) 800 rpm
- D. Silicon Carbide vs. Silicon Carbide (Dissimilar) 1800 rpm
- E. Carbon vs. Silicon Carbide 1800 rpm
- F. Silicon Carbide vs. Silicon Carbide (Dissimilar) 1200 rpm
- G. Carbon vs. Silicon Carbide 1200 rpm

The basic pressure rating is for a standard Type 37FSB seal, as shown in the typical arrangement, when installed according to the criteria given in this data sheet and generally accepted industrial practices.

The basic pressure rating assumes stable operation in a clean, cool, lubricating, nonvolatile liquid, with an adequate flush rate. For process services outside this range or a more precise assessment of the dynamic pressure rating, contact John Crane for more information.

### Materials of Construction

SEAL COMPONENTS	MATERIALS	
	Standard	Options
Primary Ring	Carbon Silicon Carbide	—
Mating Ring	Silicon Carbide	—
Secondary Sealing Element	Buna-N Ethylene Propylene	Fluoroelastomer TFE Propylene
Cord Segment	TFE Propylene	—
Retaining Ring	Inconel®	—
Clamp Ring Drive Ring Gland Plate Fasteners	316 Stainless Steel Monel® (bolts only)	—



# TYPE 37FSB

## BALANCED FULLY SPLIT SEAL

Technical Specification

### Criteria for Installation

Shaft/Sleeve	Limits
Shaft Surface Finish	125-500 Ra
Ovality/Out of Roundness (Shaft)	0.13mm/0.005"
End Play/Axial Float Allowance	± 0.76mm/0.030"
Axial Runout/Out of Squareness	2.54mm/0.100" TIR (Silicon Carbide vs. Silicon Carbide) 1.27mm/0.050" TIR (Carbon vs. Silicon Carbide)

Inconel and Monel are registered trademarks of the Special Metals Corporation Group of Companies.



**North America**  
United States of America  
Tel: 1-847-967-2400  
Fax: 1-847-967-3915

**Europe**  
United Kingdom  
Tel: 44-1753-224000  
Fax: 44-1753-224224

**Latin America**  
Brazil  
Tel: 55-11-3371-2500  
Fax: 55-11-3371-2599

**Middle East & Africa**  
United Arab Emirates  
Tel: 971-481-27800  
Fax: 971-488-62830

**Asia Pacific**  
Singapore  
Tel: 65-6518-1800  
Fax: 65-6518-1803

If the products featured will be used in a potentially dangerous and/or hazardous process, your John Crane representative should be consulted prior to their selection and use. In the interest of continuous development, John Crane Companies reserve the right to alter designs and specifications without prior notice. It is dangerous to smoke while handling products made from PTFE. Old and new PTFE products must not be incinerated. ISO 9001 and ISO14001 Certified, details available on request.