

- A – Mating ring
- B – Primary ring
- C – Metal bellows seal head
- D – Sleeve
- E – Gland

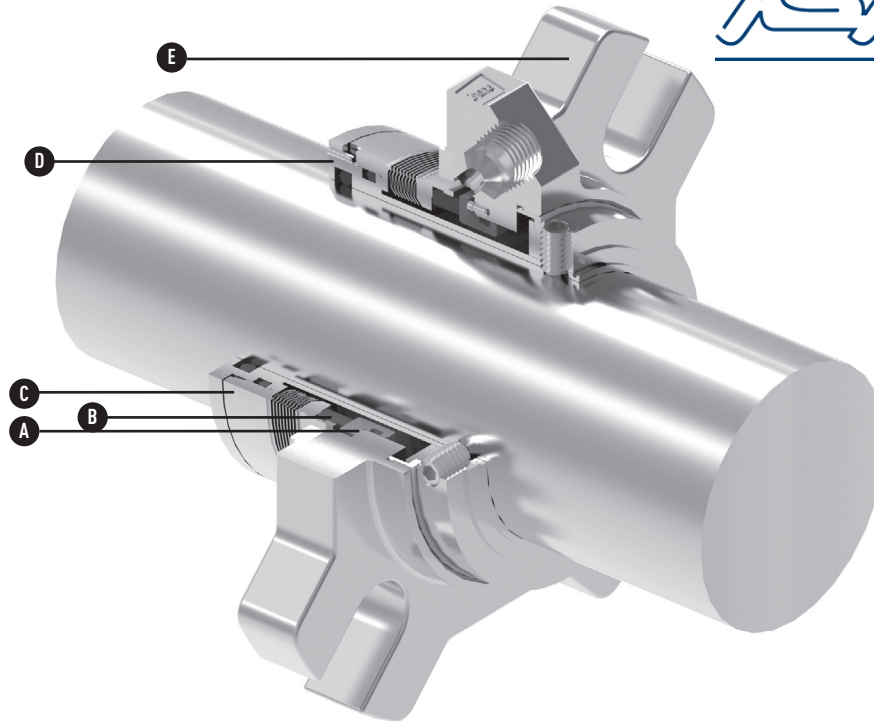

Product Description

The 4615 is a member of the 4600 family with a single seal arrangement and an edge-welded metal bellows seal head design. The abrasion- and corrosion-resistant Alloy 20CB3 SS bellows enhance reliability by eliminating dynamic O-ring hang-up caused by process contamination, thermal gradients and material deficiencies.

Type 4600 series meets key industry pump standards and is designed to permit use in rotating shaft equipment including ANSI and DIN pumps.

Design Features

- Factory assembled cartridge seal provides quick installation and eliminates installation errors.
- Abrasion- and corrosion-resistant Alloy 20CB3 SS bellows.
- Metal bellows design eliminates dynamic O-ring hang-up caused by process contamination, thermal gradients, and material deficiencies.
- Optimized primary ring design reduces face loading, horsepower consumption, heat generation and face wear.
- Reverse balanced face design allows for OD pressure and ID pressure-vacuum conditions.
- Unique pre-set PTFE centering bushing is left in place during installation meaning no need for spacer removal prior to pump start-up.

Performance Capabilities

- Temperature: -20 to 266°F/-30 to 130°C
- Pressure: Up to 220 psig/15 barg
- Speed: Up to 3,600 rpm

Application Criteria

The Type 4615 cartridge seals may be customized for specific installations after review and evaluation by John Crane. The following data is needed to evaluate the proposed service:

- | | |
|-------------------------------|--------------------|
| • Make and model of equipment | • Process fluid |
| • Shaft or sleeve OD | – Specific gravity |
| • Seal cavity dimensions | – Box pressure |
| • Speed | – Vapor pressure |
| | – Temperature |
| | – Viscosity |

TYPE 4615

SINGLE METAL BELLOWS SEAL

Standard Bore Typical Arrangement

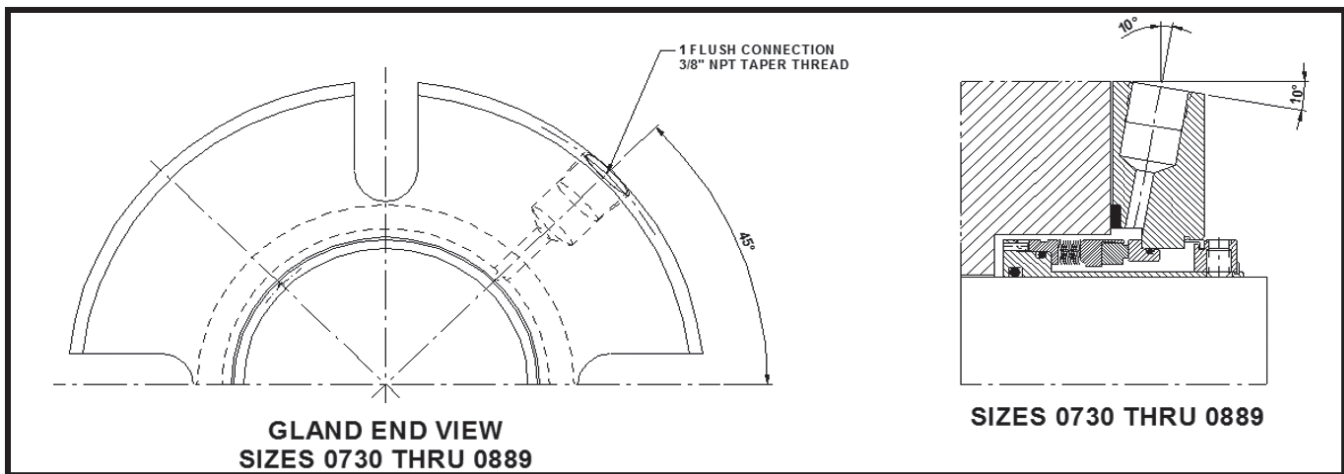
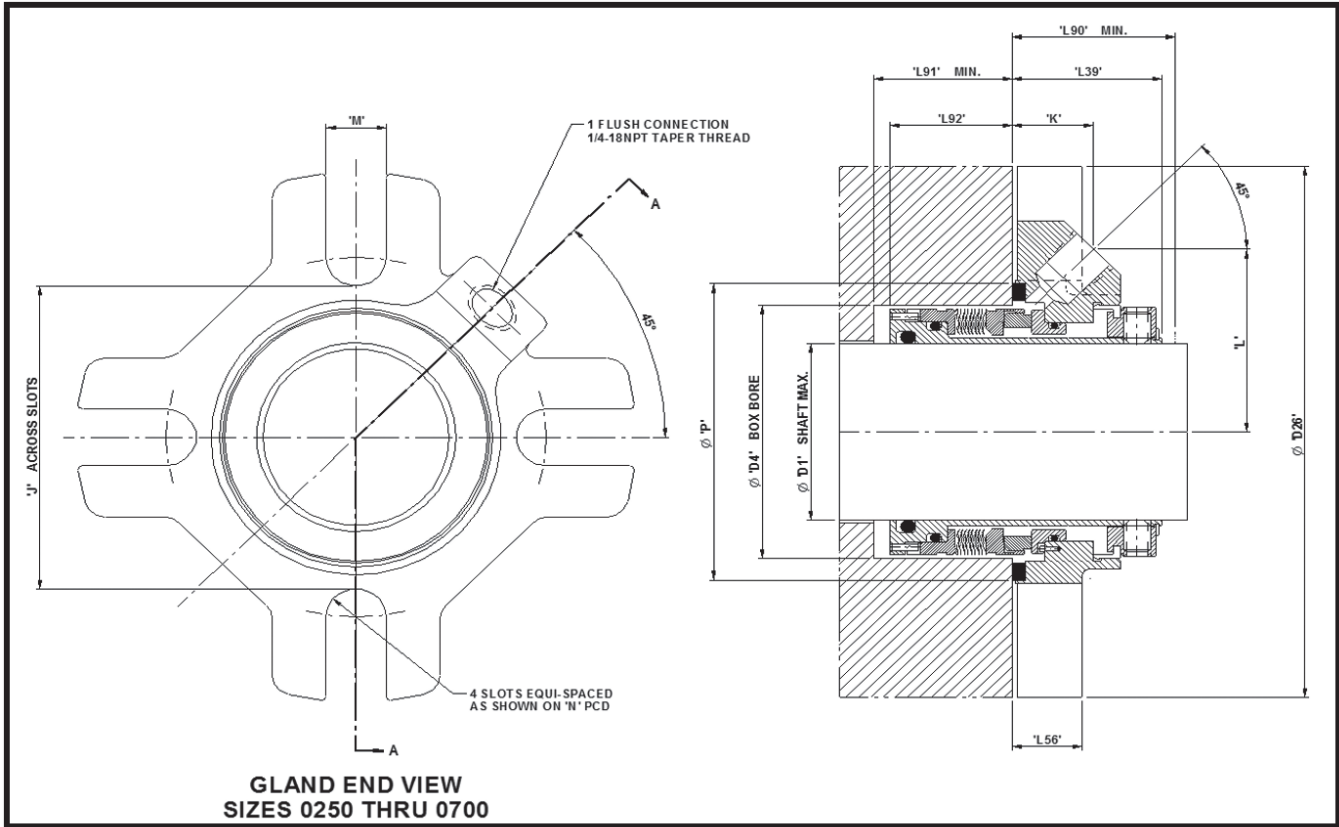

TYPE 4615

SINGLE METAL BELLOWS SEAL

Technical Specification

Dimensional Data (Inches)																
Size Code	D1	D4		D26	L92	L91	L39	M	N		J	K	L	P	L56	L90
		Min.	Max.						Min.	Max.						
254	1.000	1.625	1.937	4.125	1.064	1.189	1.364	0.437	2.625	3.750	2.189	0.753	1.345	2.126	0.503	1.489
285	1.125	1.750	2.063	4.250	1.067	1.192	1.364	0.437	2.750	3.875	2.311	0.761	1.416	2.244	0.503	1.489
317	1.250	1.875	2.189	4.370	1.064	1.189	1.364	0.437	2.875	4.000	2.437	0.748	1.488	2.382	0.503	1.489
349	1.375	2.000	2.311	4.500	1.067	1.192	1.364	0.437	3.062	4.125	2.626	0.750	1.584	2.539	0.503	1.489
381	1.500	2.250	2.500	5.000	1.136	1.261	1.409	0.563	3.434	4.500	2.874	0.768	1.723	2.795	0.661	1.534
412	1.625	2.375	2.500	5.000	1.147	1.272	1.409	0.563	3.434	4.500	2.874	0.768	1.723	2.795	0.661	1.534
444	1.750	2.500	2.626	5.250	1.152	1.277	1.409	0.563	3.562	4.750	3.000	0.763	1.808	2.933	0.661	1.534
476	1.875	2.625	3.000	5.500	1.157	1.282	1.409	0.563	3.875	5.000	3.311	0.759	1.930	3.228	0.661	1.534
508	2.000	2.750	3.000	5.500	1.157	1.282	1.409	0.563	3.875	5.000	3.311	0.759	1.930	3.228	0.661	1.534
539	2.125	2.875	3.311	5.750	1.157	1.282	1.409	0.689	4.375	5.125	3.689	0.770	2.096	3.622	0.661	1.534
571	2.250	3.000	3.311	5.750	1.162	1.287	1.409	0.689	4.375	5.125	3.689	0.770	2.096	3.622	0.661	1.534
603	2.375	3.125	3.563	6.000	1.162	1.287	1.409	0.689	4.625	5.375	3.937	0.752	2.173	3.858	0.661	1.534
635	2.500	3.375	3.874	6.250	1.269	1.394	1.428	0.689	4.875	5.625	4.189	0.729	2.353	4.114	0.661	1.553
666	2.625	3.375	3.874	6.250	1.269	1.394	1.428	0.689	4.875	5.625	4.189	0.729	2.353	4.114	0.661	1.553
698	2.750	3.625	3.874	6.250	1.269	1.394	1.428	0.689	4.875	5.625	4.189	0.693	2.389	4.114	0.661	1.553
730	2.875	3.937	4.500	8.110	1.366	1.491	1.688	0.811	5.708	6.699	4.897	0.634	3.982	4.803	1.185	1.813
762	3.000	3.937	4.500	8.110	1.366	1.491	1.688	0.811	5.708	6.699	4.897	0.634	3.982	4.803	1.185	1.813
793	3.125	4.062	4.748	8.110	1.366	1.491	1.696	0.811	5.945	6.699	5.134	0.634	3.982	5.039	1.185	1.821
825	3.250	4.187	4.748	8.110	1.366	1.491	1.696	0.811	5.945	6.699	5.134	0.634	3.982	5.039	1.185	1.821
857	3.375	4.312	4.874	8.110	1.381	1.506	1.696	0.811	6.063	6.699	5.252	0.634	3.982	5.157	1.185	1.821
889	3.500	4.437	5.000	8.504	1.381	1.506	1.696	0.811	6.220	7.093	5.409	0.654	4.176	5.315	1.185	1.821

Dimensional Data (Millimeters)																
Size Code	D1	D4		D26	L92	L91	L39	M	N		J	K	L	P	L56	L90
		Min.	Max.						Min.	Max.						
250	25	41.3	49.2	104.8	27.0	30.2	34.7	11.1	66.7	95.3	55.6	19.1	34.2	54.0	12.8	37.8
280	28	44.5	52.4	108.0	27.1	30.3	34.7	11.1	69.9	98.4	58.7	19.3	36.0	57.0	12.8	37.8
300	30	46.4	55.6	111.0	27.0	30.2	34.7	11.1	73.0	101.6	61.9	19.0	37.8	60.5	12.8	37.8
320	32	47.6	55.6	111.0	27.0	30.2	34.7	11.1	73.0	101.6	61.9	19.0	37.8	60.5	12.8	37.8
330	33	50.8	58.7	114.3	27.1	30.3	34.7	11.1	77.8	104.8	66.7	19.1	40.2	64.5	12.8	37.8
350	35	50.8	58.7	114.3	27.1	30.3	34.7	11.1	77.8	104.8	66.7	19.1	40.2	64.5	12.8	37.8
380	38	57.2	63.5	127.0	28.9	32.0	35.8	14.3	87.2	114.3	73.0	19.5	43.8	71.0	16.8	39.0
400	40	60.3	63.5	127.0	29.1	32.3	35.8	14.3	87.2	114.3	73.0	19.5	43.8	71.0	16.8	39.0
430	43	63.5	66.7	133.4	29.3	32.4	35.8	14.3	90.5	120.7	76.2	19.4	45.9	74.5	16.8	39.0
450	45	63.5	66.7	133.4	29.3	32.4	35.8	14.3	90.5	120.7	76.2	19.4	45.9	74.5	16.8	39.0
480	48	66.7	76.2	139.7	29.4	32.6	35.8	14.3	98.4	127.0	84.1	19.3	49.0	82.0	16.8	39.0
500	50	69.9	76.2	139.7	29.4	32.6	35.8	14.3	98.4	127.0	84.1	19.3	49.0	82.0	16.8	39.0
530	53	73.0	84.1	146.1	29.4	32.6	35.8	17.5	111.1	130.2	93.7	19.6	53.2	92.0	16.8	39.0
550	55	73.0	84.1	146.1	29.4	32.6	35.8	17.5	111.1	130.2	93.7	19.6	53.2	92.0	16.8	39.0
580	58	79.4	90.5	152.4	29.5	32.7	35.8	17.5	117.5	136.5	100.0	19.1	55.2	98.0	16.8	39.0
600	60	79.4	90.5	152.4	29.5	32.7	35.8	17.5	117.5	136.5	100.0	19.1	55.2	98.0	16.8	39.0
630	63	85.7	98.4	158.8	32.2	35.4	36.3	17.5	123.8	142.9	106.4	18.5	59.8	104.5	16.8	39.5
650	65	85.7	98.4	158.8	32.2	35.4	36.3	17.5	123.8	142.9	106.4	18.5	59.8	104.5	16.8	39.5
700	70	92.1	98.4	158.8	32.2	35.4	36.3	17.5	123.8	142.9	106.4	17.6	60.7	104.5	16.8	39.5
750	75	100.0	114.3	206.0	34.7	37.9	42.9	20.6	145.0	170.2	124.4	16.1	101.1	122.0	30.1	46.1
800	80	106.4	120.6	206.0	34.7	37.9	43.1	20.6	151.0	170.2	130.4	16.1	101.1	128.0	30.1	46.3
850	85	109.5	123.8	206.0	35.1	38.3	43.1	20.6	154.0	170.2	133.4	16.1	101.1	131.0	30.1	46.3



TYPE 4615

SINGLE METAL BELLOWS SEAL

Technical Specification

Layout Drawing Numbers

Size Code	Seal Size		Layout Drawing Number
	Inches	mm	
0250		25	GA-233865
0254	1.000		GA-233866
0280		28	GA-233867
0285	1.125		GA-233868
0300		30	GA-233869
0317	1.250		GA-233870
0320		32	GA-233871
0330		33	GA-233872
0349	1.375		GA-233873
0350		35	GA-233874
0380		38	GA-233875
0381	1.500		GA-233876
0400		40	GA-233877
0412	1.625		GA-233878
0430		43	GA-233879
0444	1.750		GA-237803
0450		45	GA-233880
0476	1.875		GA-233881
0480		48	GA-233882
0500		50	GA-233883
0508	2.000		GA-233884
0530		53	GA-233885

Size Code	Seal Size		Layout Drawing Number
	Inches	mm	
0539	2.125		GA-233886
0550		55	GA-233887
0571	2.250		GA-233888
0580		58	GA-233889
0600		60	GA-233890
0603	2.375		GA-233891
0630		63	GA-233892
0635	2.500		GA-233893
0650		65	GA-233894
0666	2.625		GA-233895
0698	2.750		GA-233896
0700		70	GA-233897
0730	2.875		GA-233898
0750		75	GA-233899
0762	3.000		GA-233900
0793	3.125		GA-233901
0800		80	GA-233902
0825	3.250		GA-233903
0850		85	GA-233904
0857	3.375		GA-233905
0889	3.500		GA-233906

TYPE 4615

SINGLE METAL BELLOWS SEAL

Big Bore Typical Arrangement

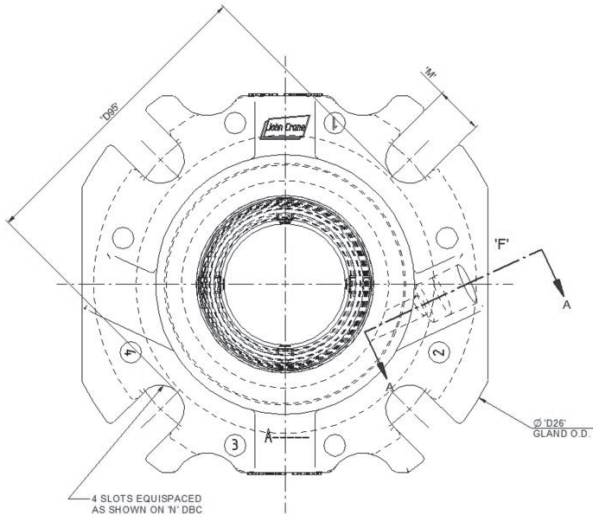

GLAND END VIEW
SIZES 0349, 0444, 0635, 0698

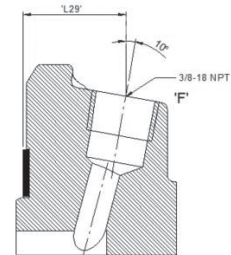
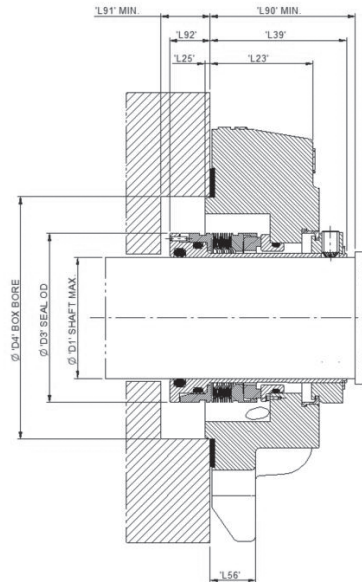

SECTION A-A

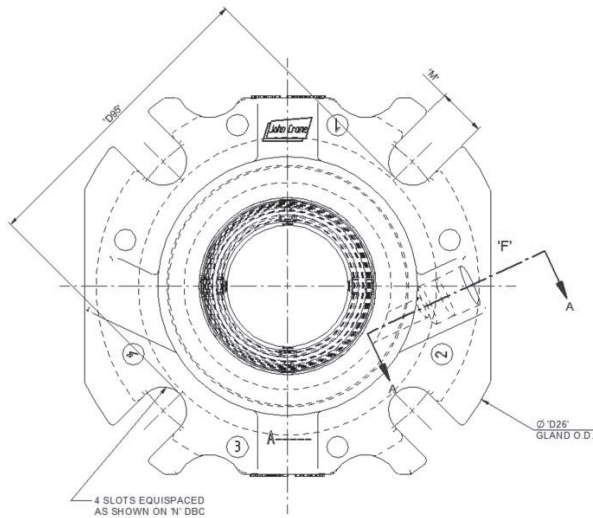

GLAND END VIEW
SIZES 0476, 0666

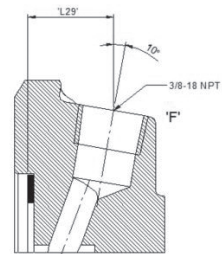
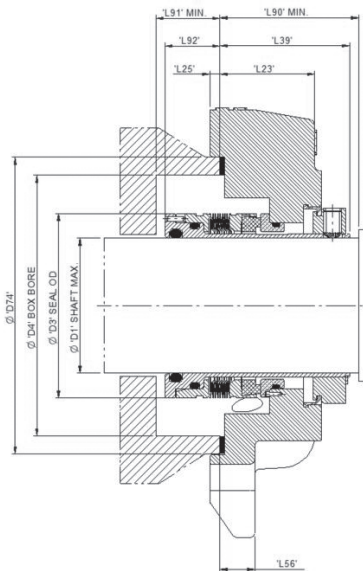

SECTION A-A

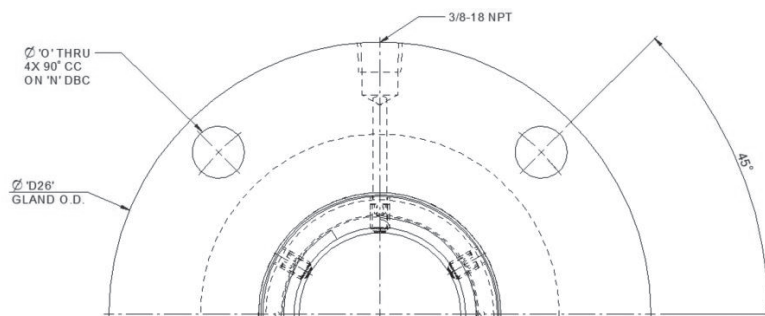

GLAND END VIEW
SIZE 0539

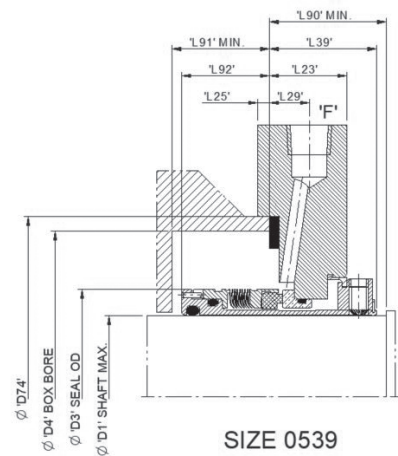

SIZE 0539



TYPE 4615

SINGLE METAL BELLOWS SEAL

Technical Specification

Dimensional Data (Inches)																		
Size Code	D1	D3	D4		D26	D74	D95	L23	L25	L29	L39	L56	L90	L91	L92	M	N	O
			Min.	Max.														
0349	1.375	1.937	2.875	3.023	5.375	N/A	3.500	1.446	0.046	1.017	1.928	0.623	2.053	0.628	0.503	0.562	4.062	N/A
0444	1.750	2.437	3.500	3.925	6.500	N/A	4.403	1.487	0.077	1.058	1.975	0.656	2.100	0.711	0.586	0.687	5.093	N/A
0476	1.875	2.562	3.625	3.734	6.500	4.125	4.403	1.316	0.140	0.885	1.804	0.485	1.929	0.887	0.762	0.687	5.093	N/A
0539	2.215	2.812	2.875	4.187	7.156	4.562	N/A	1.018	0.153	0.526	1.412	N/A	1.537	1.279	1.154	N/A	5.250	0.437
0539	2.215	2.812	2.875	4.336	7.125	4.711	N/A	1.018	0.153	0.526	1.412	N/A	1.537	1.279	1.154	N/A	6.000	0.687
0635	2.500	3.312	4.750	4.875	8.000	N/A	5.375	1.695	0.079	1.266	2.261	0.656	2.386	0.561	0.436	0.687	6.062	N/A
0666	2.625	3.312	4.625	4.740	8.000	5.125	5.375	1.617	0.140	1.185	2.307	0.578	2.432	0.516	0.390	0.687	6.062	N/A
0698	2.750	3.562	4.750	4.875	8.000	N/A	5.375	1.695	0.079	1.266	2.261	0.656	2.386	0.561	0.436	0.687	6.062	N/A

Layout Drawing Numbers		
Size Code	Size (Inches)	Layout Drawing Number
0444	1.75	GA-247299
0476	1.875	GA-247300
0539	2.125	GA-247578
0539	2.125	GA-247301
0635	2.5	GA-247302
0666	2.625	GA-247304
0698	2.75	GA-247305

Pressure Rating Limits

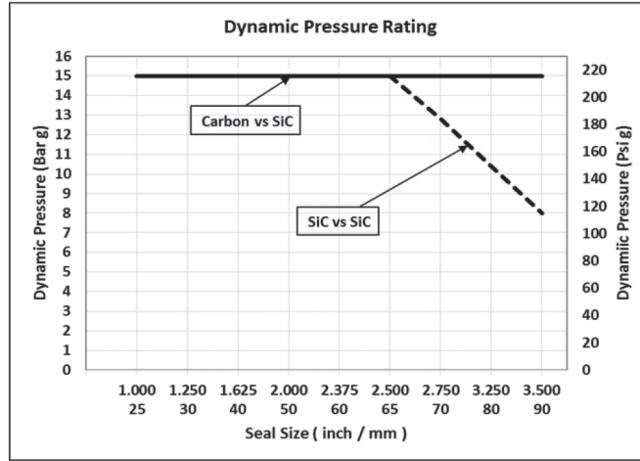

Figure 1: Dynamic pressure rating graph

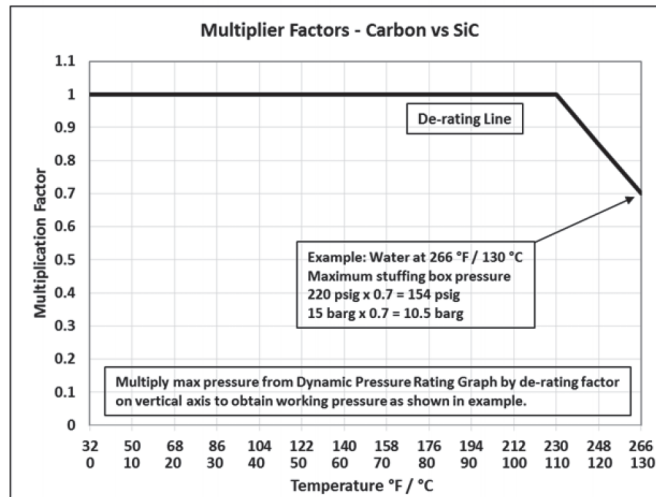

Figure 2: Multiplier factor - Carbon vs SiC

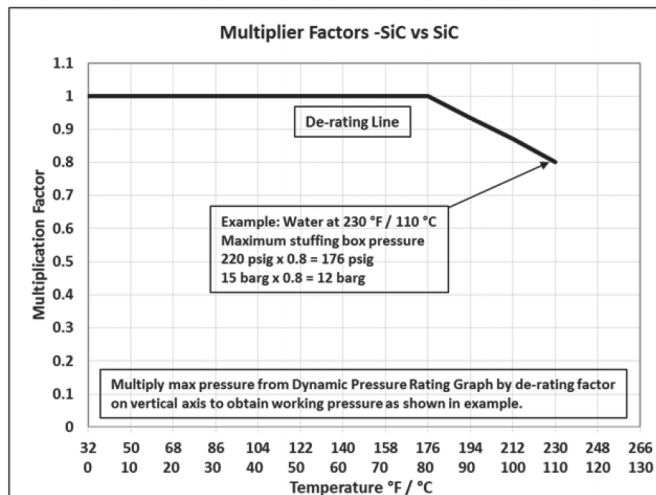

Figure 3: Multiplier factor - SiC vs SiC

Multiplier Factors

	Selection Consideration	Multiplier Factor
Sealed fluid lubricity (applies to SiC vs SiC face combination only)	Petro/Gasoline, kerosene or better	x 1.00
	Water and aqueous solutions	x 0.75
Sealed fluid temperature (applies to Carbon vs SiC face)	Up to 230 °F/110 °C	x 1.00
	> 230 °F to 266 °F/ > 110 °C to 130 °C	x (< 1.0 to 0.7) see Fig. 2
Sealed fluid temperature (applies to SiC vs SiC face)	Up to 175 °F/80 °C	x 1.00
	> 175 °F to 230 °F/ > 80 °C to 110 °C	x (< 1.0 to 0.8) see Fig 3

Example of determining pressure rating limits:

Seal:	2.000 inch/50.8 mm type 4615
Operating temperature:	266°F/130°C
Speed:	1800 rpm
Barrier fluid:	Aqueous solution
Face materials:	Carbon vs. silicon carbide

Using the pressure rating graph Fig. 1, the maximum pressure would be 220 psig/15 barg. From the Multiplier Factors table on the left, apply the multipliers for the specific service requirements to determine the maximum operating pressure for the application.

Max dynamic pressure x Temp MF x Lubricity MF = Max Operating Pressure

220 psig x 0.70 x 1.0 = 154 psig or 15 barg x 0.70 x 1.0 = 10.5 barg

The maximum operating pressure for this 2.000 inch/50.8 mm Type 4615 seal is 154 psig/10.5 barg.

Standard Materials

Seal component	Standard material	Material options
Primary ring	Carbon (9003) Silicon carbide (9221)	—
Mating ring	Silicon carbide (9221)	Tungsten carbide (9205)
Bellows assembly	Alloy 20CB3 SS (0560)	—
Seal Hardware	316 stainless steel (0550)	—
O-ring	Fluoroelastomer (9549)	Ethylene propylene (9561) Neoprene (9523) Nitrile (9501)
Gland gasket	Glass filled PTFE (7510)	—
Centering ring (spacer)	Glass filled PTFE (7517)	—