

- A – Mating Ring
- B – Primary Ring
- C – Drive Ring
- D – Bellows

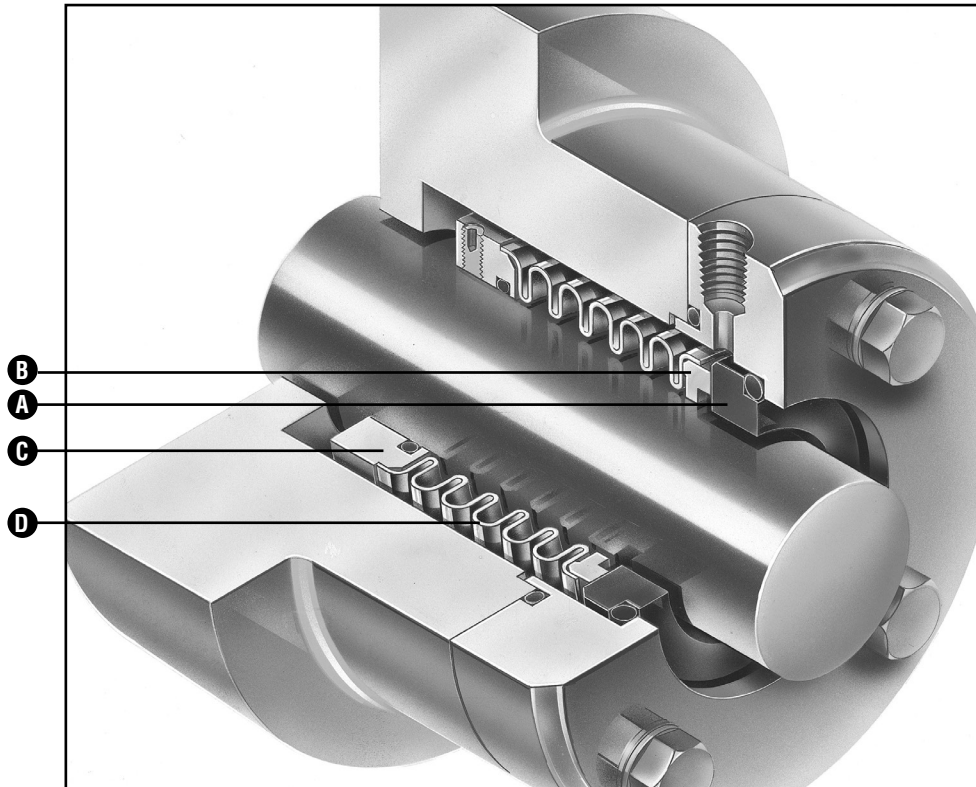

### Product Description

The Type 515E is a formed metal bellows seal with a computer optimised asymmetric bellows profile. General sealing duties include: biotechnology, chemical processing, mining, oil, oil refining, pulp and paper, pharmaceutical, wastewater treatment and water systems. The 515E is ideal where hygiene and purity are essential, such as food preparation and the pharmaceutical industry.

### Typical Applications

- Hygienic and high purity Applications
- Abrasive fluids
- Slurries
- Aqueous solutions
- Chemicals
- Lubricants

### Performance Capabilities

- Temperature: -40°F to 300°F/-40°C to 150°C
- Pressure: up to 20 bar(g)/290 psi(g)
- Speeds: up to 25 m/s/5000 fpm

### Design Features

- The asymmetric bellows profile – provides even stress distribution in the bellows for greater reliability.
- Available with alternative mating rings/seats, primary ring, and secondary seal components to suit your particular installation, product and operating conditions.
- Compact design complies with DIN 24960/L1 (N), ISO 3069 and BS.5257:1975. Inch sizes up to and including 2.625 in. also comply with ANSI B73.1.M.

# TYPE 515E

## ASYMMETRIC FORMED METAL BELLOWS SEAL

### Type 515E Typical Arrangement

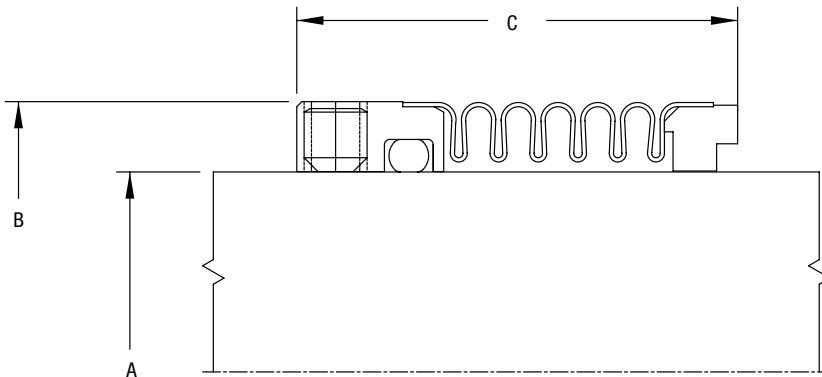

### Type 515E Dimensional Data (inch)

seal size code	$\pm 0.002''/A$	B	C
0190	0.750	1.220	1.240
0222	0.875	1.417	1.457
0254	1.000	1.535	1.476
0285	1.125	1.654	1.496
0317	1.250	1.811	1.693
0349	1.375	1.909	1.693
0381	1.500	2.028	1.654
0412	1.625	2.297	1.850
0444	1.750	2.297	1.850
0476	1.875	2.508	1.831
0508	2.000	2.508	1.831
0539	2.125	2.717	2.224
0571	2.250	2.886	2.224
0603	2.375	3.020	2.224
0635	2.500	3.126	2.224
0666	2.625	3.268	2.618
0698	2.750	3.457	2.579
0730	2.875	3.701	2.579
0762	3.000	3.701	2.579
0793	3.125	3.959	2.953
0825	3.250	3.959	2.953
0857	3.375	4.173	2.953
0889	3.500	4.341	2.953
0920	3.625	4.524	2.953
0952	3.750	4.524	2.953
0984	3.875	4.774	2.953
1016	4.000	4.774	2.953

### Type 515E Dimensional Data (mm)

seal size code	$\pm 0.05/A$	B	C
0180	18	31	31.5
0200	20	31	31.5
0220	22	31	31.5
0240	24	36	36.7
0250	25	36	37
0280	28	39	37.5
0300	30	42	38
0320	32	46	43
0330	33	46	43
0350	35	48.5	43
0380	38	51.5	42
0400	40	54	42
0430	43	58.35	47
0450	45	58.35	47
0480	48	63.7	47
0500	50	63.7	46.5
0530	53	69	56.5
0550	55	71	56.5
0580	58	73.3	56.5
0600	60	76.7	56.5
0630	63	79.4	56.5
0650	65	83	66.5
0680	68	87.8	66.5
0700	70	87.8	65.5
0750	75	94	65.5
0800	80	100.55	75
0850	85	106	75
0900	90	110.25	75
0950	95	114.9	75
1000	100	121.25	75

# TYPE 515E

## ASYMMETRIC FORMED METAL BELLOWS SEAL

### Pressure/Velocity (PV) Limits

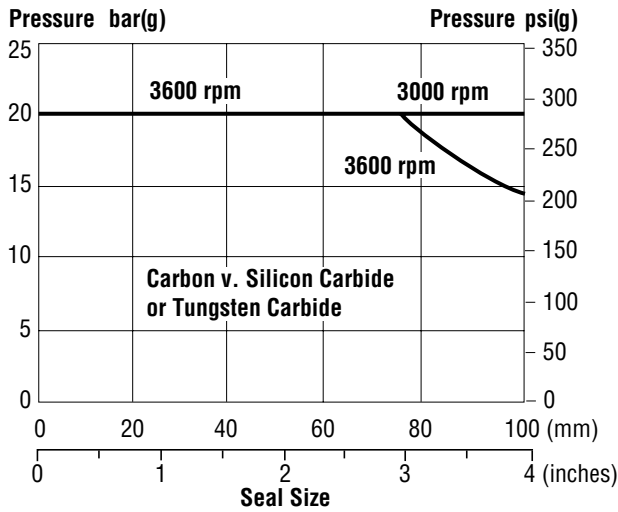

To determine the maximum pressure for the size of Type 515E seal required, multiply the pressure obtained from the chart by the appropriate factors given in chart below.

### Hydrostatic Pressure Limits

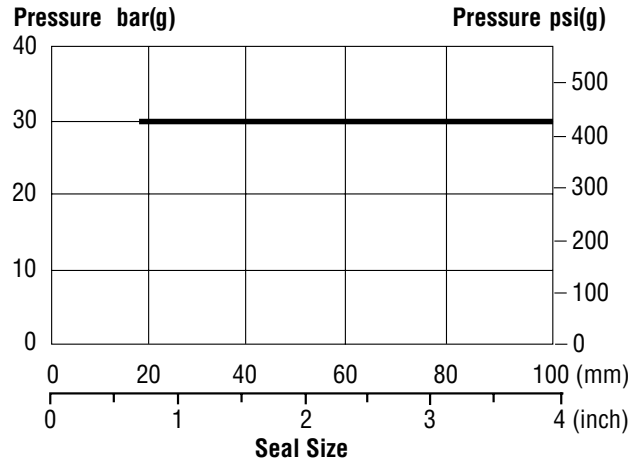

### P V Multiplier Factors

	Selection Considerations	Multiplier Factor
<b>Sealed Fluid Lubricity</b>	Petrol, Kerosene or better Water, Aqueous Solutions, Lighter Hydrocarbons (s.g. <0.65), etc.	x 1.00* x 1.00* x 0.75**
<b>Primary and Mating Ring Materials</b>	Carbon v. Silicon Carbide or Tungsten Carbide Silicon Carbide Coated Graphite v. Silicon Carbide	x 1.00 x 1.00
<b>Sealed Fluid Temperature</b>	200°C/390°F and below	x 1.00
<b>Speed</b>	3600 rpm and below	x 1.00

\* Seal size codes up to and including 65mm/2.625in.

\*\* Seal size codes above 65mm/2.625in.

#### Example for Determining PV Limits:

**Seal:** 80mm diameter Type 515E

**Product:** Water

**Face materials:** carbon v. silicon carbide

**Operating temperature:** 30°C/85°F

**Operating speed:** 3600 rpm

Using chart 3, the maximum pressure would be 19.0 bar(g)/276 psi(g).

From chart 5, apply the multiplier factors for the specific service requirements:

19.0 bar(g)/276 psi(g) x 1.00 x 1.00 x 0.75 x 1.00 = 14.25 bar(g)/207 psi(g).

Therefore, for the example given, the maximum operating pressure is 14.25 bar(g)/207 psi(g).

The operating parameters shown can be exceeded for certain applications: if the required operating pressure is greater than the calculated PV limit, please consult your John Crane representative.

### Secondary Seal Temperature Limits

Material	Temperature
Medium Nitrile	-40°C to +100°C/-40°F to +210°F
Fluorocarbon	-30°C to +200°C/-20°F to +390°F
Ethylene Propylene*	-40°C to +135°C/-40°F to +275°F
Perfluoroelastomer	-20°C to +200°C/-5°F to +390°F
Medium Nitrile (F.D.A.)**	-40°C to +100°C/-40°F to +210°F
Ethylene Propylene (F.D.A.)*	-40°C to +135°C/-40°F to +275°F

\* Not to be used for hydrocarbons or mineral oils.

\*\* Can withstand repeated steam sterilisation at +120°C/250°F without adverse effect.

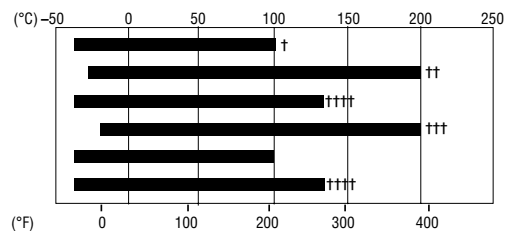

† For hydrocarbon duties the limit is +120°C/250°F.

†† For water duties the temperature should not exceed +135°C/275°F.

††† Although rated to a higher temperature, material should be limited to +200°C/390°F in this seal.

†††† For water/steam duties the limit is +150°C/300°F.

### Criteria for Installation

Shaft/Sleeve	Limits
Surface Finish	1.6 µm/63 µin Ra
Ovality/ Out of Roundness	0.05 mm/0.002 in.
End Play/ Axial Float Allowance	0.08 mm/0.003 in. F.I.M.
Housing Squareness to Shaft	See chart below.

### Operating Limits

Pressure		Temperature	Speed
Operating	Static Test		
Refer to Pressure/ Velocity (PV) Limits	Refer to Hydrostatic Pressure Limits	Refer to Secondary Seal Temperature Limits	25 m/s/ 5000 fpm Maximum

Note: For applications with speeds greater than 25 m/s or 4000 rpm, a rotating seat (RS) arrangement is recommended.

### Material Availability

SEAL COMPONENTS		MATERIALS	
Description		Standard	Optional
Bellows Assembly	Bellows Convolutions	Inconel Nickel Chromium Alloy	—
	Drive Ring	Precipitation Hardening Stainless Steel	Duplex Stainless Steel
	Setscrews	316 Stainless Steel	Alloy C-276
	Primary Ring	Resin Impregnated Carbon Graphite	Silicon Carbide Coated Graphite
Secondary Seal O-ring		Medium Nitrile Ethylene Propylene Fluorocarbon	Medium Nitrile† Ethylene Propylene† Perfluoroelastomer

† Material complies with The USA Federal Drug Administration (F.D.A.) Title 21 Paragraph 177.2600.

### Housing Squareness to Shaft

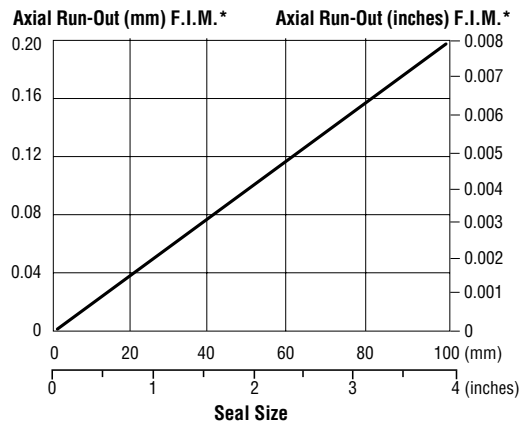

\* F.I.M. = Full Indicator Movement

Inconel is a registered trademark of Inco Alloys International, Inc.

### Recommendations for Viscous Fluids

- 0 - 1,000 cSt: Standard Seal
- 1,000 - 3,500 cSt: Hard Face Material
- 3,500 - 10,500 cSt: Consult John Crane

Note: SSU (Saybolt Universal Seconds) approximately equals  
 $cSt \text{ (centistoke)} \times 4.6347cP \text{ (centipoise)} =$   
 $cSt \text{ (centistoke)} \times \text{specific gravity}.$



**North America**  
 United States of America  
 Tel: 1-847-967-2400  
 Fax: 1-847-967-3915

**Europe**  
 United Kingdom  
 Tel: 44-1753-224000  
 Fax: 44-1753-224224

**Latin America**  
 Brazil  
 Tel: 55-11-3371-2500  
 Fax: 55-11-3371-2599

**Middle East & Africa**  
 United Arab Emirates  
 Tel: 971-481-27800  
 Fax: 971-488-62830

**Asia Pacific**  
 Singapore  
 Tel: 65-6518-1800  
 Fax: 65-6518-1803

If the products featured will be used in a potentially dangerous and/or hazardous process, your John Crane representative should be consulted prior to their selection and use. In the interest of continuous development, John Crane Companies reserve the right to alter designs and specifications without prior notice. It is dangerous to smoke while handling products made from PTFE. Old and new PTFE products must not be incinerated. ISO 9001 and ISO 14001 Certified, details available on request.