

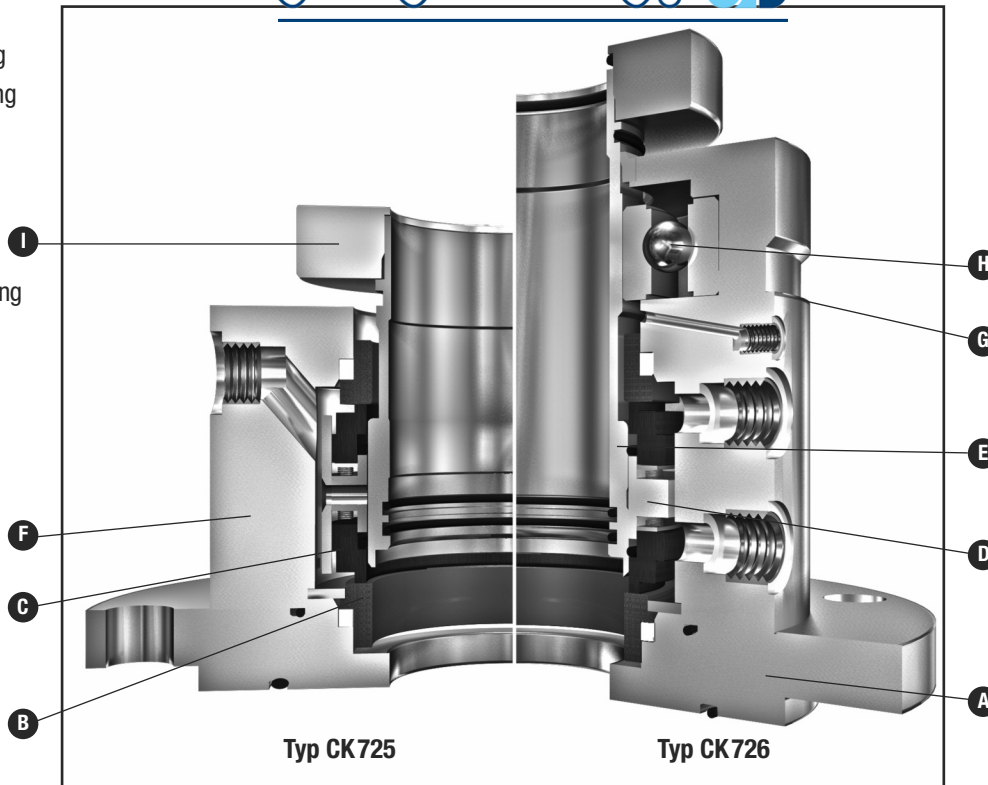

- A – DIN Flange
- B – Seat/Mating Ring
- C – Face/Primary Ring
- D – Retainer
- E – Sleeve
- F – Housing
- G – Gauging Edge
- H – Type CK726 Bearing
- I – Clamp Ring



Product Description

Type CK725 and Type CK726 vessel and agitator seals are dual cartridge seals compliant with vessel seal standard DIN 28138 Parts 1 and 3. They are designed for use on agitator vessels made of steel to DIN 28136, to fit on a mounting flange to DIN 28141 and agitator shaft end dimensions to DIN 28154. A cartridge integrated radial bearing for optimal shaft alignment distinguishes Type CK726 from Type CK725. Both liquid lubricated and dry running versions are available.

All versions are suitable for operation in potentially explosive atmospheres. Depending on individual explosion protection requirements, the seal operating limits may differ from the values given in this data sheet. Consult John Crane for more information.

Performance Capabilities*

- Speed: 0 to 570 rpm (up to 430 rpm for dry running)
- Vessel pressure vacuum to 16 bar(g)
- Barrier pressure: maximum 18 bar(g)
- Temperature: -40°C to +200°C
- Shaft run out: radial: 1.0 mm (CK725) axial: +/- 1.0 mm

*Maximum values (dependant on combination of operating conditions). For details see chart operating limits in family brochure B-DINVesselSeals/Eng. For operating conditions outside these limits consult John Crane.

Design Features

- Dual cartridge seal to DIN 28138 for stainless steel vessels
- Fits mounting flange to DIN 28141 and shaft end dimensions to DIN 28154
- Back-to-back seal arrangement with unbalanced faces
- Liquid lubricated or dry running (D) face versions available
- Reverse pressure capabilities inboard
- Type CK725 without radial bearing
- Type CK726 cartridge incorporates a radial bearing
- Non-standard sizes, special designs and material options are available on request
- Debris well and cooling flange options available
- Suitable for application in explosive areas. Certificates of conformity according to European Directive 94/9/EC (ATEX) Cat. 1, 2 and 3 available on request
- Limits of operation without barrier pressure available upon request

TYPE CK725/CK726

FOR STEEL VESSELS

Type CK725/CK726 Typical Arrangement/Dimensional Data (mm)

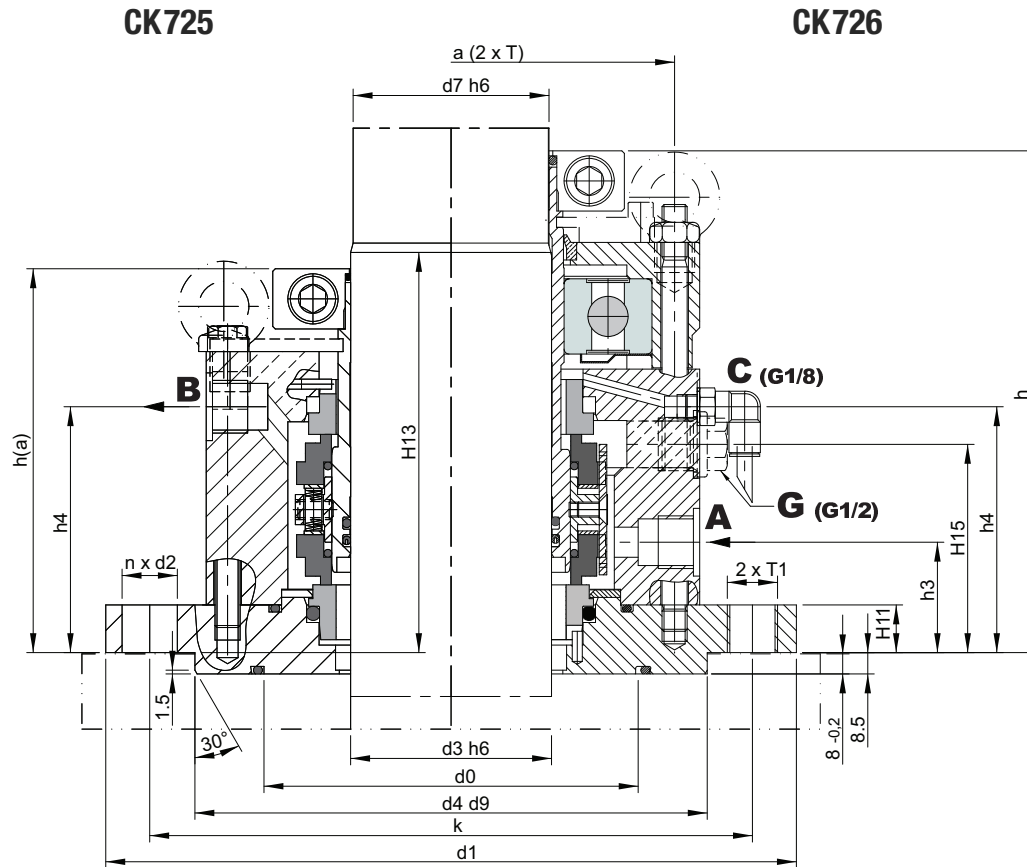

CK725
CK726

Liquid lubricated

CK725 D
CK726 D

Dry running, easy barrier gas supply
with dry nitrogen

Seal Size	Flange Connectivity			Fastening			Cartridge Dimensions							Connections & Mounting				
	d3	d0	d1	d4	k	n x d2	bolt	d7	h(a)	h	h3	h4	H11	H13	H15	A & B	a	T
40	91	175	110	145	4 x 18	M16	38	131.5	169.5	33	91	13	135	80	G 3/8	126	M12	M16
50	107	240	176	210	8 x 18	M16	48	132.5	175.5	35	93	16	140	80	G 3/8	136	M12	M16
60	116	240	176	210	8 x 18	M16	58	144.5	185	36	94	18	150	84.5	G 3/8	145	M12	M16
80	147	275	204	240	8 x 22	M20	78	153	200	44	98	19	160	83	G 1/2	178	M16	M20
100	173	305	234	270	8 x 22	M20	98	164	210	41	108	21	170	94	G 1/2	208	M16	M20
125	198	330	260	295	8 x 22	M20	120	175	235	40	113	20	195	100	G 1/2	235	M20	M20
140	218	395	313	350	12 x 22	M20	135	257	284	53	171	30	200	155	G 1/2	270	M20	M20
160	237	395	313	350	12 x 22	M20	150	275	281.5	55	180	30	205	155	G 1/2	279	M20	M20

Dimensions according to DIN 28138 Parts 1 & 3 and DIN 28154 - special dimensions and designs available.



North America
United States of America
Tel: 1-847-967-2400
Fax: 1-847-967-3915

Europe
United Kingdom
Tel: 44-1753-224000
Fax: 44-1753-224224

Latin America
Brazil
Tel: 55-11-3371-2500
Fax: 55-11-3371-2599

Middle East & Africa
United Arab Emirates
Tel: 971-481-27800
Fax: 971-488-62830

Asia Pacific
Singapore
Tel: 65-6518-1800
Fax: 65-6518-1803

If the products featured will be used in a potentially dangerous and/or hazardous process, your John Crane representative should be consulted prior to their selection and use. In the interest of continuous development, John Crane Companies reserve the right to alter designs and specifications without prior notice. It is dangerous to smoke while handling products made from PTFE. Old and new PTFE products must not be incinerated. ISO 9001 and ISO14001 Certified, details available on request.