

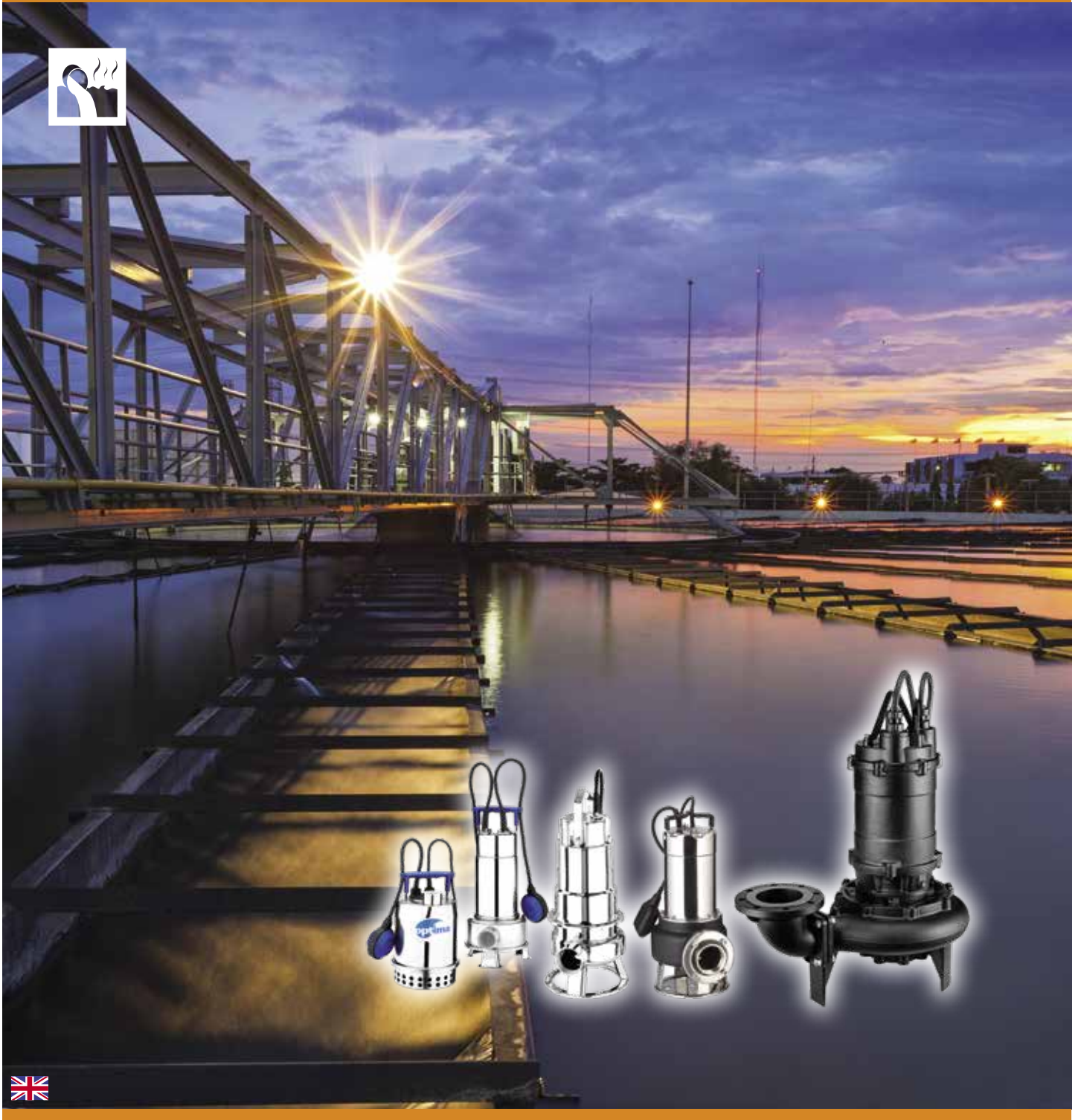



Submersible electric Pumps

Product Catalogue





www.ebara-europe.com

Looking ahead,
going beyond expectations
Ahead  *Beyond*



We have simply thought of everything

Our range of submersed pumps has been designed to meet all needs related to the pumping, treatment and movement of waste waters and clear waters, and in all situations in which the water used contains solid residues.

The different types of submersed pumps, linked to the wide range of accessories available, ensure high performance and versatility of use.

The emptying of wells, garages and cellars or the lifting of rain/waste waters, industrial applications and irrigation of gardens and orchards require different technical and construction characteristics. Our submersed pumps offer the most suitable solutions for different needs ensuring the best possible performance for the specific application and ensuring high reliability of operation.

The flexibility and manageability of the smaller models allows their use in fixed or mobile applications. The vortex impellers, single or semi-open, those equipped with a cutter and those with a grinder-type shredder allows the treatment black water with the presence of solid or filamentous substances.

The accessories available for the different models, such as the magnetic float for clear water or the minimum suction device up to 3 mm, allow completion of the functions of the pumps increasingly adapting to the demands of different uses.



RELIABILITY

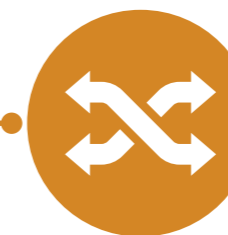

VERSATILITY AND FLEXIBILITY



FREE PASSAGE OF SOLIDS



HIGH EFFICIENCY



Sectors and Areas of Application

- **Emptying of wells, garages and cellars**
For the emptying of domestic premises subject to flooding or water infiltrations.
- **Emptying of tanks and cisterns**
For aspiration from water recovery systems
- **Handling of load liquids of solid or filamentous substances in suspension**
For the drainage of sludge with solid or filamentous particles
- **Civil and industrial waste water evacuation**
For the drainage of discharges of residential or industrial uses
- **Drainage of sublevel areas**
For the extraction of water from lower level areas
- **Emptying of cesspools**
For the emptying residential and industrial sewage systems
- **The lifting of rainwater**
For movement of the water contained in rainwater recovery tanks
- **Irrigation of gardens and vegetable gardens**
For gardening and small-scale agriculture



Technology, performance, quality in two different forms: steel and cast iron

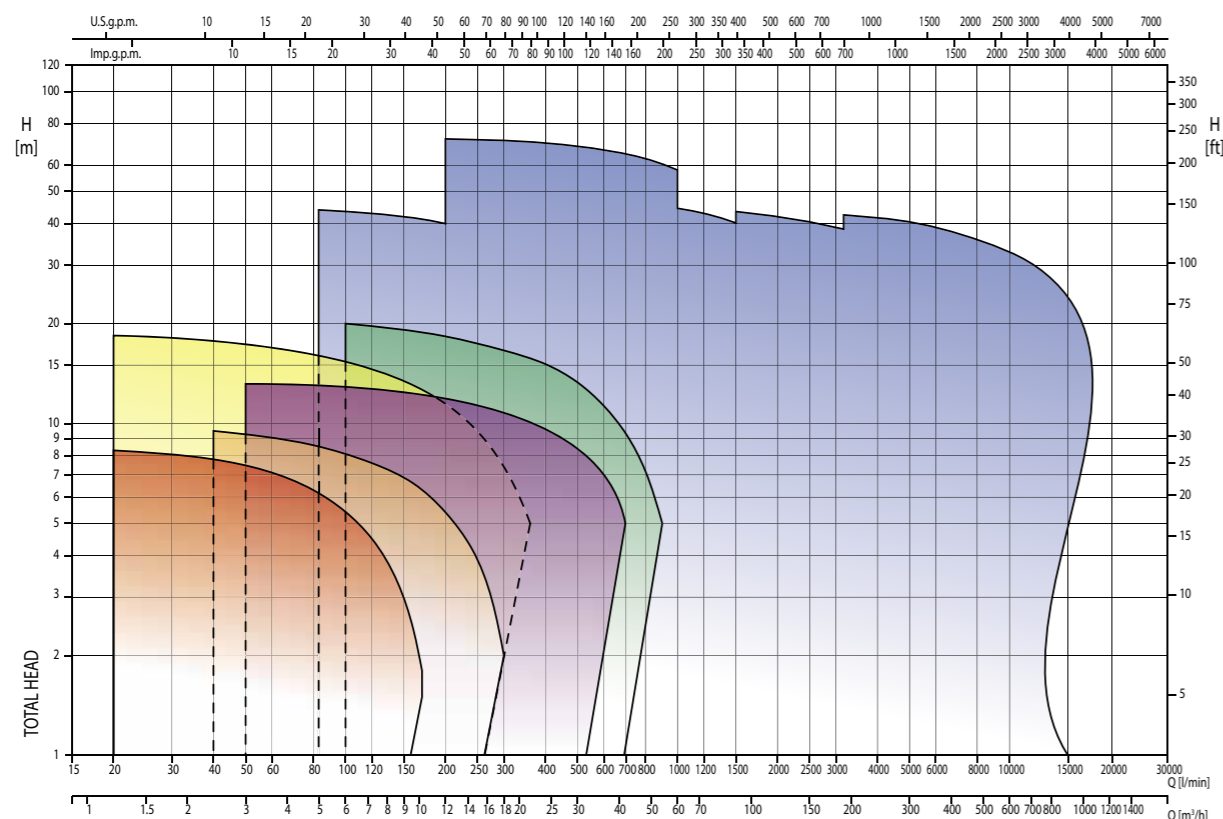

Technology, Performance, Quality: words that can take on different shapes and meanings. For EBARA they assume a **precise meaning**.

They represent the characteristics that distinguish their products and that are also found in the wide range of submersed electric pumps: high technology used in production, performance of a very wide range that covers the most types of use, quality in the details and precision of the technical solutions adopted.

The submersed electric pumps summarise all this in two different families: steel submersibles and cast-iron submersibles. The **steel** range was also conceived and designed to offer high quality standards in the field of domestic applications.

The range of **cast iron** electric pumps, on the other hand, is ideal for residential and industrial uses and ensures high performance even in the most extreme situations.

The same quality, the same technology, the same EBARA imprint in two different forms: Steel and Cast iron.

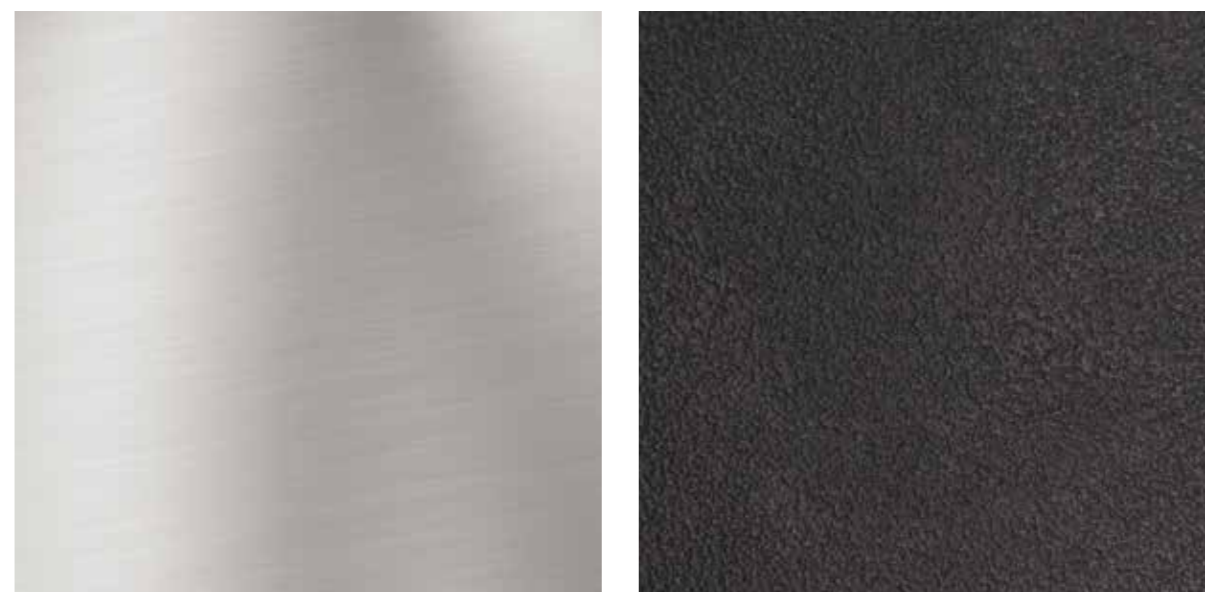

STEEL

STEEL - From long and proven industry experience, high technology comes to small household electric pumps

Small domestic pumps or for large industrial plants, there is no difference. Our goal is to offer the product that best suits requirements, in every situation. For these reasons we offer our experience, gained in more than 100 years in the field of waste water treatment, both for industrial products and for domestic pumps.

The electric pumps are made of stainless steel AISI 304, to ensure maximum reliability and resistance. The technical solutions adopted, as well as the matching accessories, ensure this range of high performance and a variety of solutions that adapt to any need.

The OPTIMA, easy-to-use light-water electric pumps, are part of this range. The BEST ONES, also for clear waters that also feature the vortex type impeller option (BEST ONE VOX version). Following on, with similar constructive characteristics but offering greater performance, are the BEST 2 - 5. The two larger models complete the range of submersed steel pumps: the RIGHTS, suitable for waste water and the DW - DW VOX, used with sewage and also available with a vortex impeller.

The Vox type impellers available on a number of models, as well as the minimal suction device or the magnetic float, are accessories that best express the versatility of domestic pumps. Quality and technological innovation, distinctive signs of EBARA.

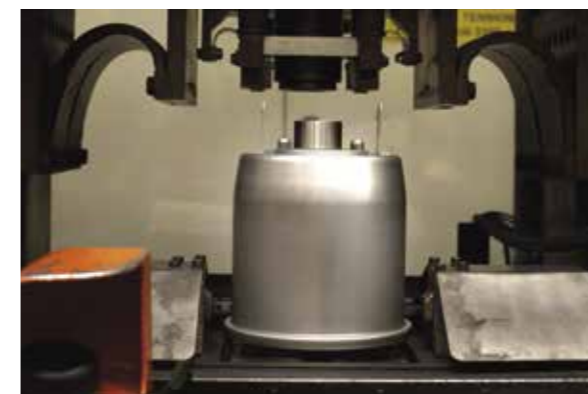
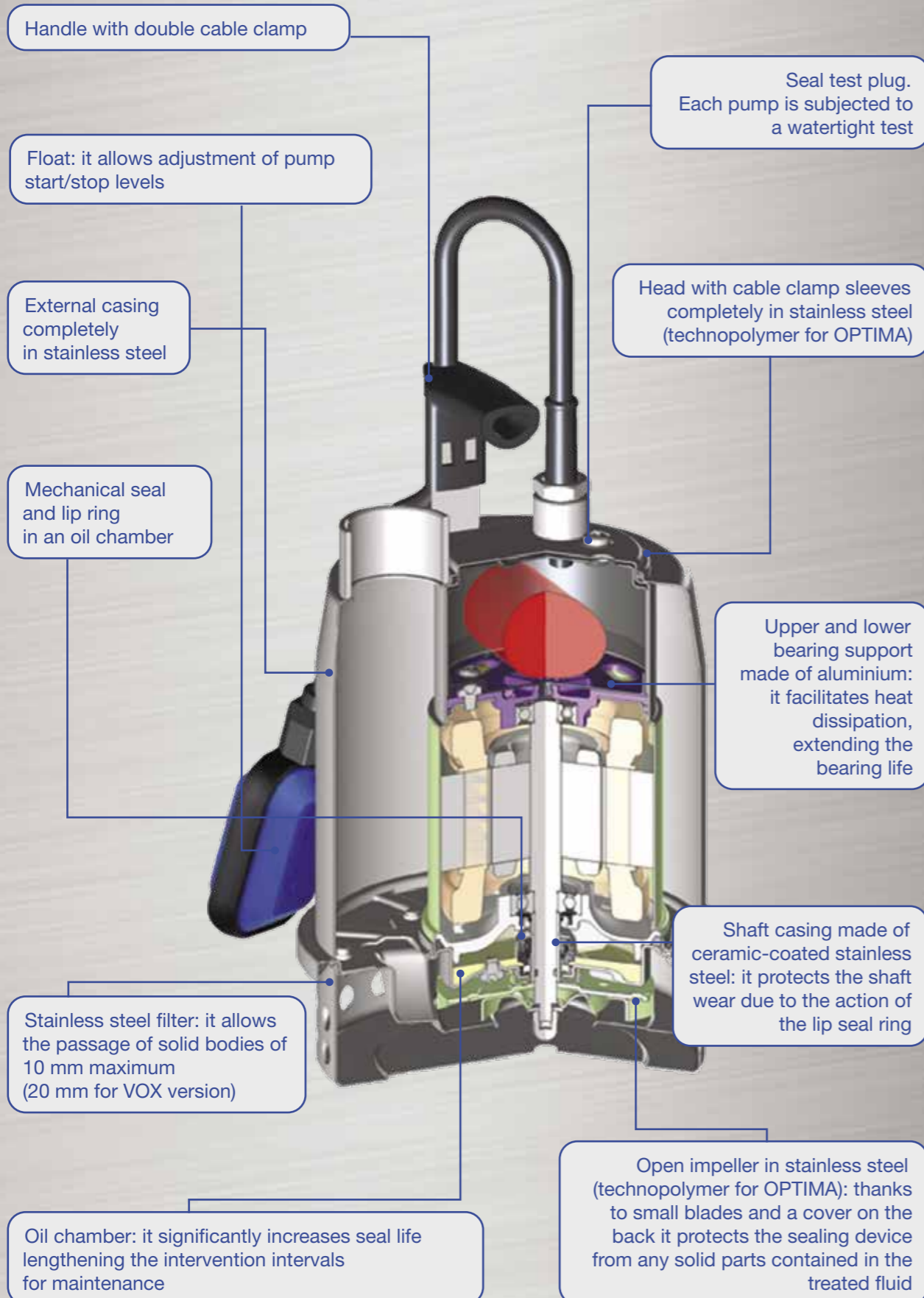

OPTIMA

Submersible pumps in AISI 304

Submersible electric pump for clear water with AISI 304 stainless steel hydraulics.

Pump body, intake grille, seal holder disc and motor casing are in AISI 304.

Impeller in PPE + PS reinforced with glass fibres and shaft in AISI 303.

The mechanical seal is standard (Ceramic/Carbon/NBR)

- MA version (fig.1) with float

- MS version (fig.3) with MS vertical magnetic float with reduced dimensions for clean water

Accessories

• 1"¼ hose connector and relative hose clamp (optional)

• Minimum suction device up to 3 mm (fig. 2)



Practical and easy to use



Possibility of use in fixed and mobile installations



Resistant to corrosion

- Total head from 1.5 to 7.6 m
- Capacity from 1.2 to 9 m³/h
- Maximum immersion 5 m
- Maximum liquid temperature 50°C
- Maximum solid size passage 10 mm



Performance curve

50Hz

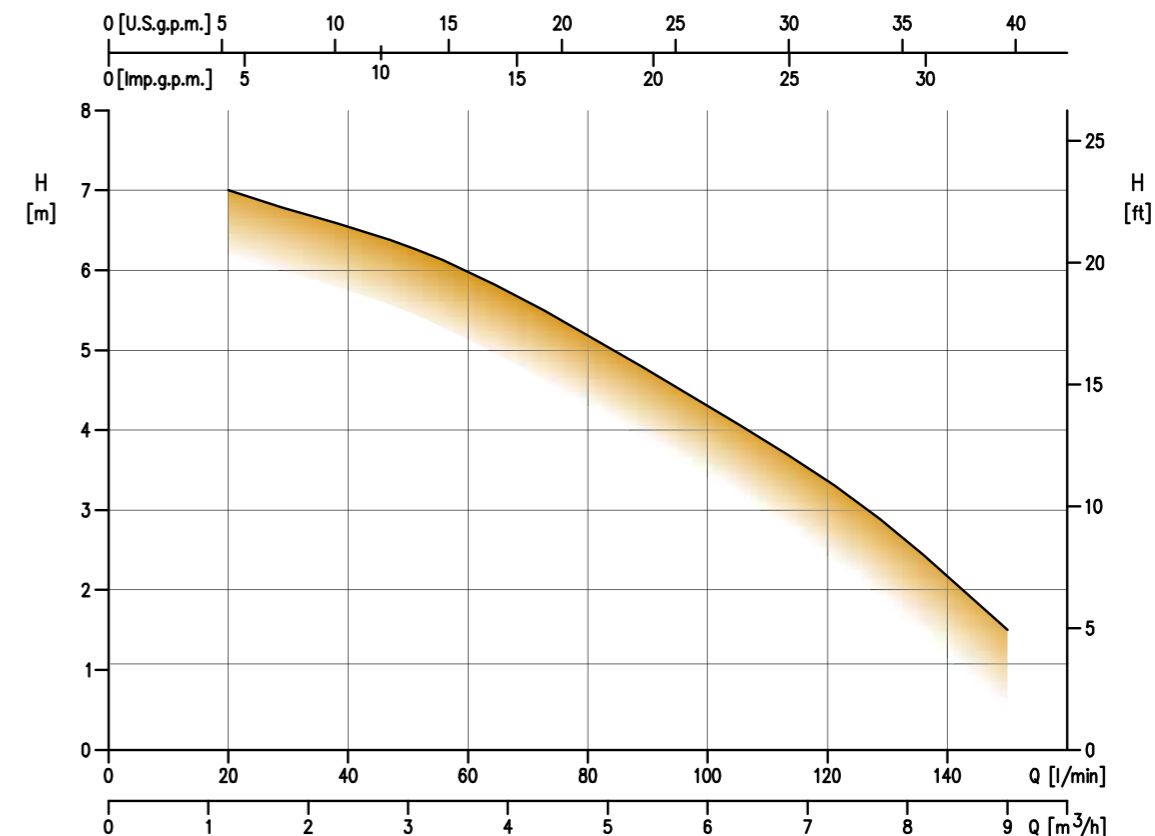

INSTALLATION

The OPTIMA electric pumps have a wide versatility of installation. The possibility of choosing between the vertical magnetic float (small) or the float switch allows choosing of the best option, also based on the space available to insert the pump. Furthermore, the choice of switch type also depends on the water level for which pump start is preferred.

OPTIMA MS

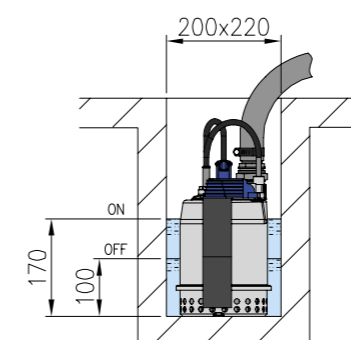

OPTIMA MA

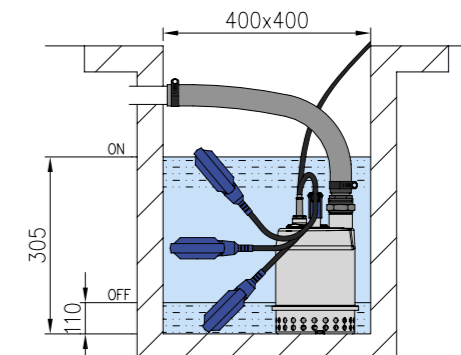

BEST ONE - ONE VOX

Fully submersed electric pumps in AISI 304



Possibility of use in fixed and mobile installations



Resistant to corrosion



Practical and easy to use

Submersible electric pump for clear water with AISI 304 stainless steel hydraulics. Outer casing, impeller, filter, motor cover, seal holder disc and motor case all in AISI 304, shaft in AISI 303. The mechanical seal is standard in Ceramic/Carbon/NBR. Provided with 5 m of power cable type H05 RN - F (single phase), H07 RN - F (three phase) for internal use, with or without float.

Special Versions

- Version MA (fig. 1) with float
- Version VORTEX (VOX) (fig. 2)
- Version MA (fig. 3) with magnetic float MS vertical with reduced dimensions for clean water

Accessories

- 1 1/4" hose connector and relative hose clamp (optional)
- Minimum suction device up to 3 mm (fig. 4)

- Total head from 1.8 to 8.3 m for BEST ONE and from 1.5 to 6 m for BEST ONE VOX
- Capacity from 1.2 to 10.2 m³/h
- Maximum immersion 5 m
- Maximum liquid temperature 50°C
- Maximum solid size passage:
 - 10 mm
 - 20 mm for version VOX (VORTEX)



MS magnetic float (vertical)
It allows the use of floating pumps where space is limited (not compatible with low suction device)

Low suction device
It allows aspiration to 3 mm from the ground (only for M and MA version). Easily mountable with simple pressing.

Performance curve

50Hz

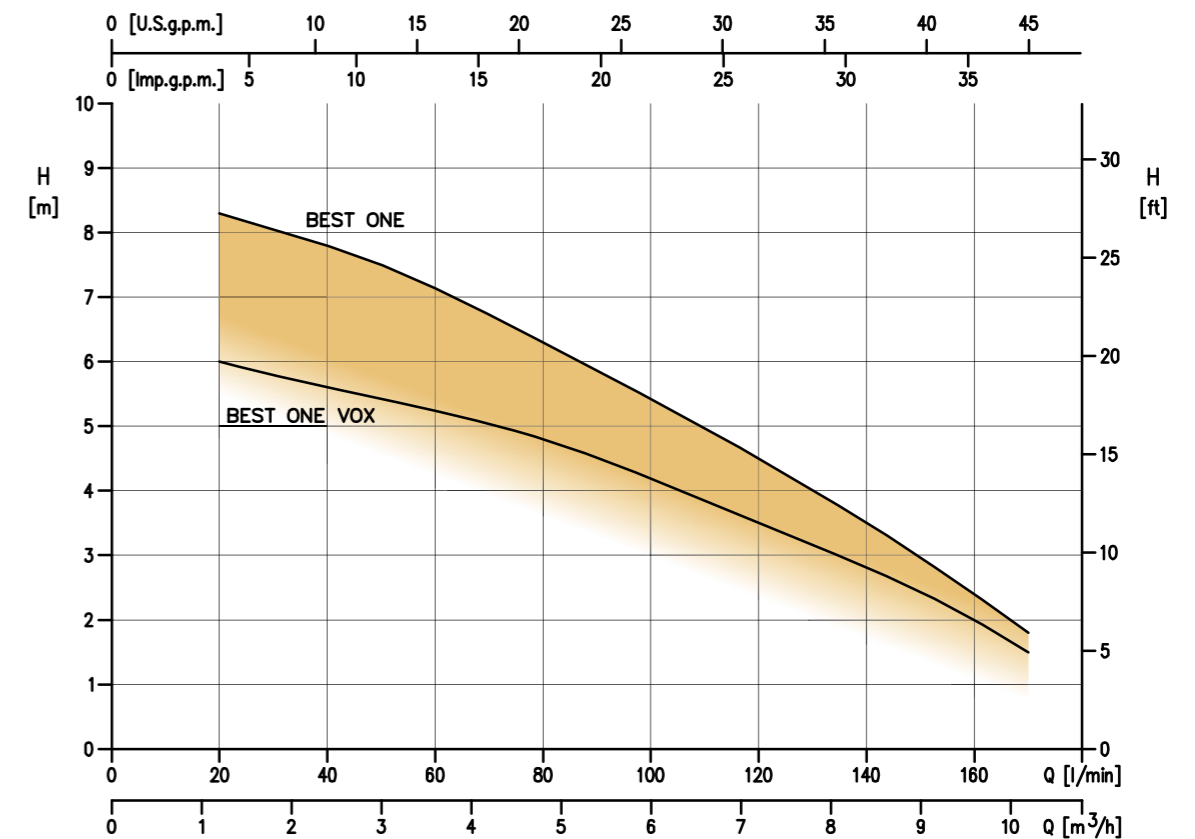

INSTALLATION

The BEST ONE electric pumps have a wide versatility of installation. The possibility of choosing between the vertical magnetic float (small) or the float switch allows choosing of the best option also based on the space available to insert the pump. Furthermore, the choice of switch type also depends on the water level for which pump start is preferred.

BEST ONE MS

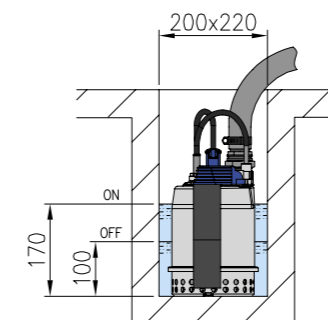

BEST ONE MA

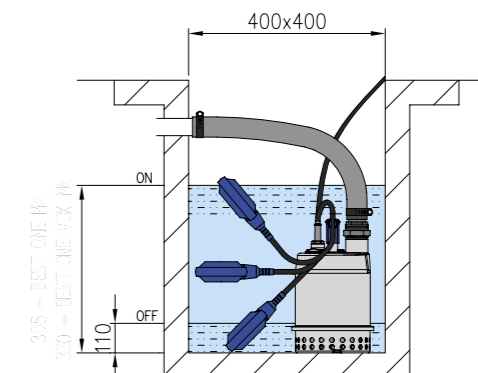

BEST 2-5

Submersible pumps in AISI 304

Submersible electric pump completely in AISI 304 stainless steel.

The pump body, the impeller, the suction grille, the motor cover, the seal holder disc and the motor case are in AISI 304.

The shaft is in AISI 303 (part in contact with the liquid). Double mechanical seal with oil chamber: the upper one in Carbon/Ceramic/NBR (motor side), the lower one in SiC/SiC/NBR (pump side).

Special Versions

- MA Version with float



Possibility of use in fixed and mobile installations



Practical and easy to use

- Total head from 2.9 to 18.4 m
- Capacity from 1.2 to 21.6 m³/h
- Maximum immersion 7 m
- Maximum liquid temperature 35°C
- Maximum solid size passage 10 mm



Performance curve

50Hz

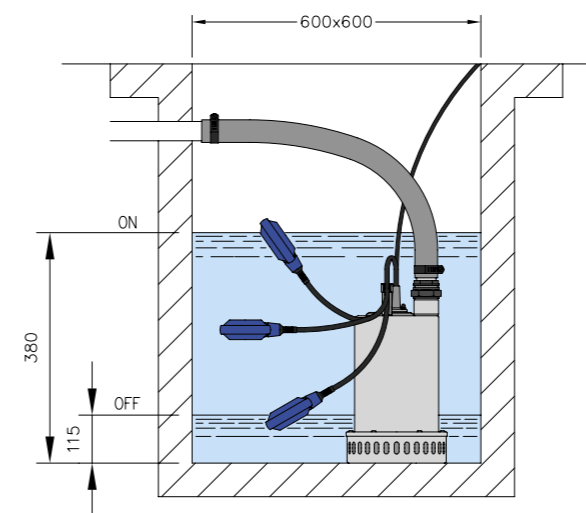
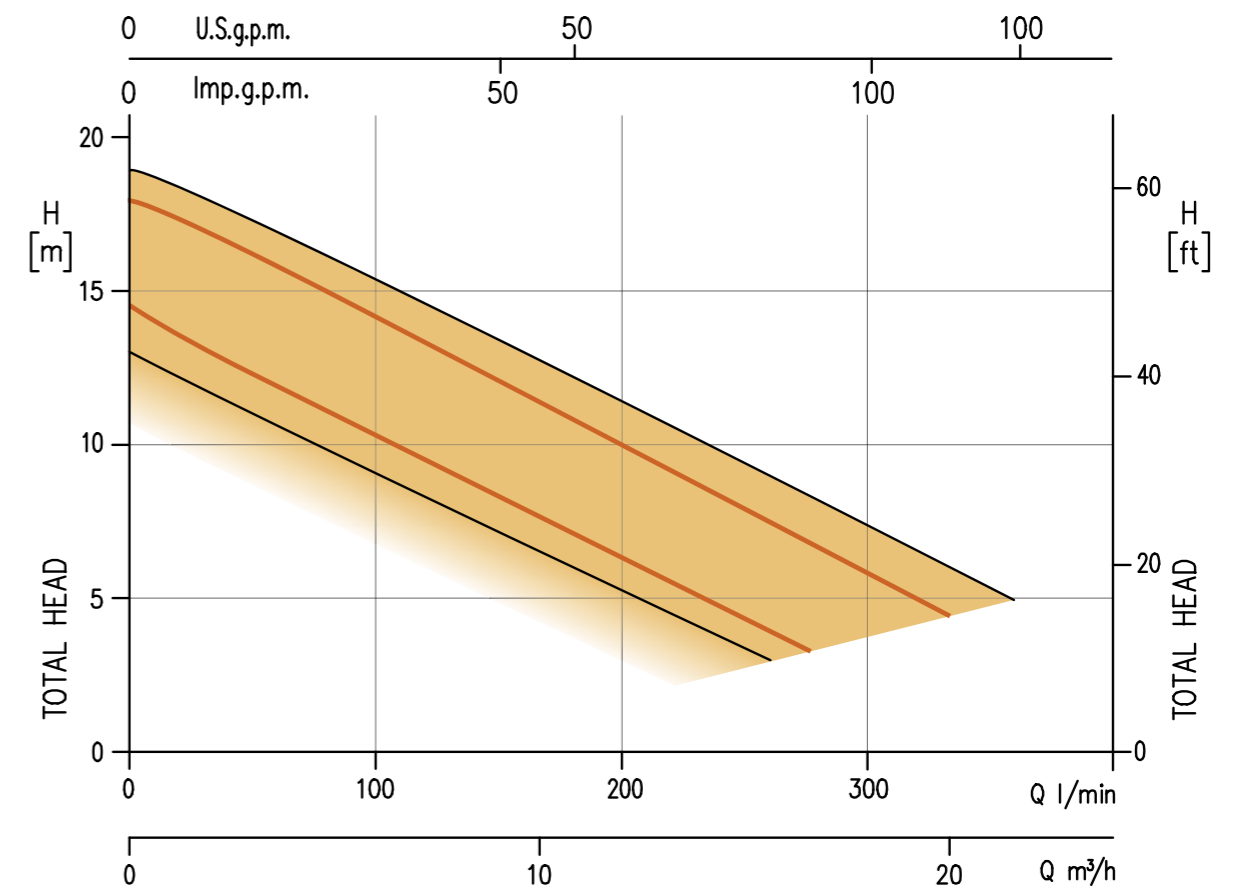

INSTALLATION

The BEST 2 - 5 electric pumps are also available with a float switch, thus increasing the versatility of use. The choice of the use of the float switch requires the respecting of minimum installation spaces to guarantee correct operation of the pump itself.

RIGHT

Submersible electric pumps for waste water in AISI 304

Submersible electric pump for waste water in AISI 304 stainless steel. Pump body, impeller, motor cover, seal holder disc and motor case in AISI 304. Shaft in AISI 303 (part in contact with the liquid). Present the double mechanical seal with oil chamber: the upper one in Carbon/Ceramic/NBR (motor side) and the lower one in SiC/SiC/NBR (pump side).

Special Versions

- MA Version with float
- Version with 10 m of cable



Accessories

Adapter for use of the DW descent kit with RIGHT pumps



Possibility of use in fixed and mobile installations



- Total head from 2 to 9.5 m
- Capacity from 2.4 to 18 m³/h
- Maximum immersion 7 m
- Maximum liquid temperature 50°C
- Maximum solid size passage 35 mm
- Provided with 5 m of power cable type H07 RN - F (on request 10 m of power cable)

Performance curve

50Hz

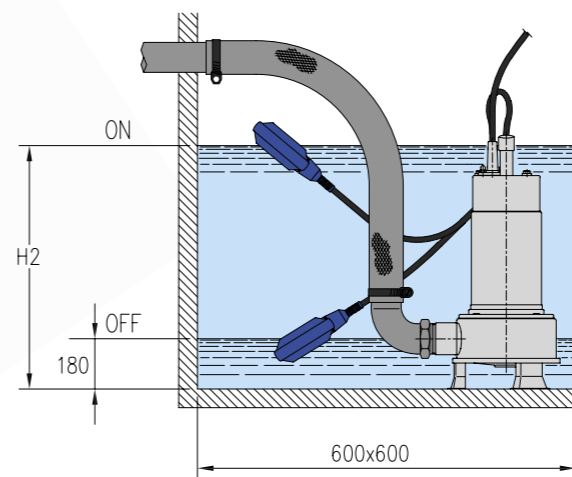
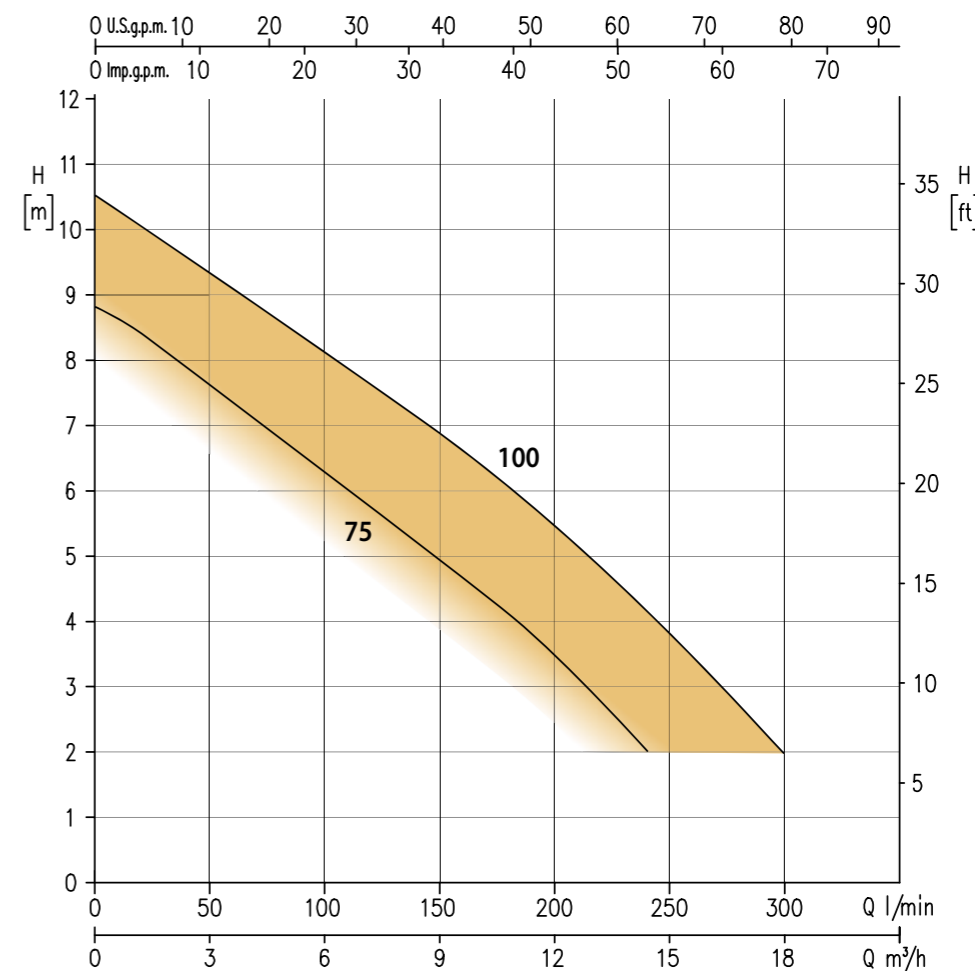

INSTALLATION

The RIGHT electric pumps are also available with a float switch, thus increasing the versatility of use. The choice of the use of the float switch requires the respecting of minimum installation spaces to guarantee correct operation of the pump itself.

DW – DW VOX

Submersible electric pumps for waste water in AISI 304

Submersible electric pumps in stainless steel AISI 304 for waste water. They have a pump body, impeller, motor cover, seal holder disc and motor case in AISI 304, while the shaft is in AISI 303. Double mechanical seal with interposed oil chamber: the upper one in carbon/ceramic/NBR (motor side), the lower one in SiC/SiC/NBR (pump side). G20 cast iron spacer (only for DW – DW VOX 300). Available single-phase versions with or without float.

Special Versions

- Single-channel impeller version (DW)
- Vortex type impeller version (DW VOX)
- Flanged version (DWF/DW VOXF)

Accessories

Descent device kit

- Guide hook DW - DW VOX in cast iron
- Fixed hook DW - DW VOX in cast iron
- On request version with special seal of Tungsten Carbide/Tungsten Carbide + FPM O-Ring

- Total head from 2.2 to 20 m for DW and from 1.6 a 15.7 m for DW VOX
- Capacity from 6 a 54 m³/h for DW and from 6 to 48 m³/h for DW VOX
- Maximum immersion 7 m
- Maximum liquid temperature 40°C
- Maximum solid size passage 50 mm



Possibility of use in fixed and mobile installations



Performance curve

50Hz

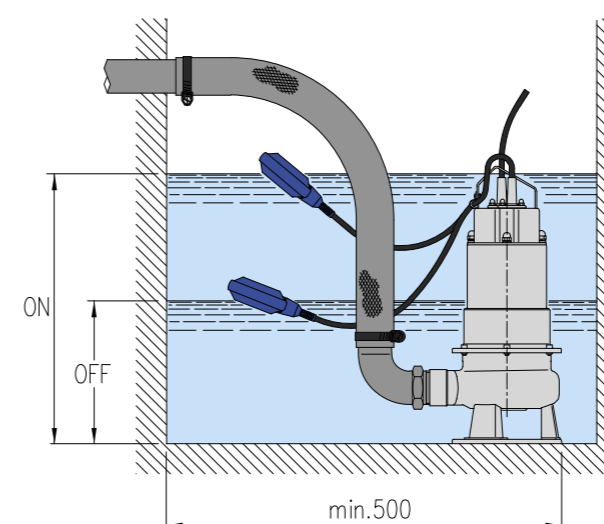
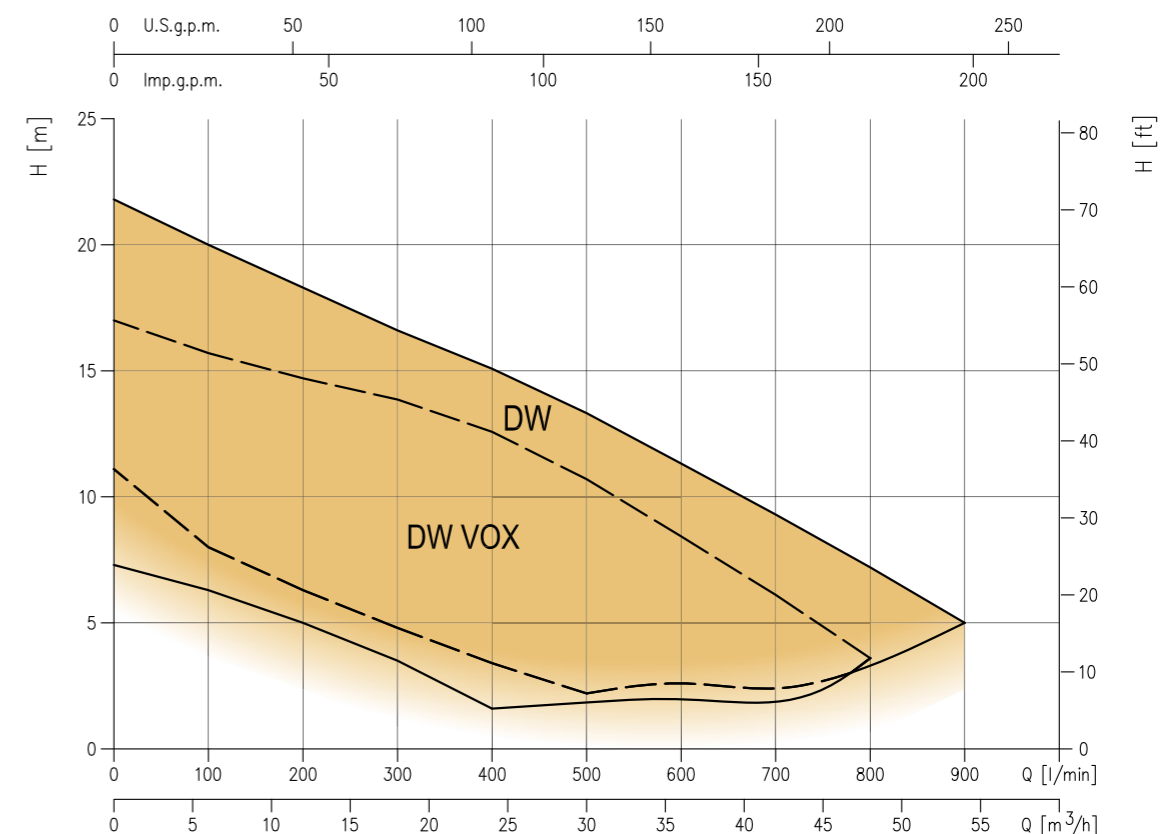

INSTALLATION

The DW - DW VOX electric pumps are also available with a float switch, thus increasing the versatility of use. The choice of the use of the float switch requires the respecting of minimum installation spaces to guarantee correct operation of the pump itself.

DAR

Submersible pumps for wastewater dual-channel or vortex impeller

Submersible electric pumps with **vortex** and **dual-channel impeller**, for **sewage applications**. Suitable for handling liquids containing solid and/or filamentary substances in suspension and for draining sewage water (sanitary fixtures). They are also recommended for draining cesspits and discharging into the sewer.

Mechanical seals in Graphite/Ceramic/NBR (impeller side) e NBR seal ring (motor side) for 50DAR, in Silicium Carbide/Ceramic/NBR (impeller side) NBR seal ring (motor side).



Vortex impeller



Dual-channel impeller

- Total Head from 3,2 to 15 m per 50DAR from 2 to 12,5 m per 65DAR
- Capacity from 3 to 42 m³/h per 50DAR from 3 to 54 m³/h per 65DAR
- Maximum immersion 7 m
- Maximum liquid temperature: 25°C partially submersed pump 35°C totally submersed pump
- Maximum solid size passage: 50-65 mm

Flanged
65DAR

Threaded
50DAR

Curva di prestazione

50Hz

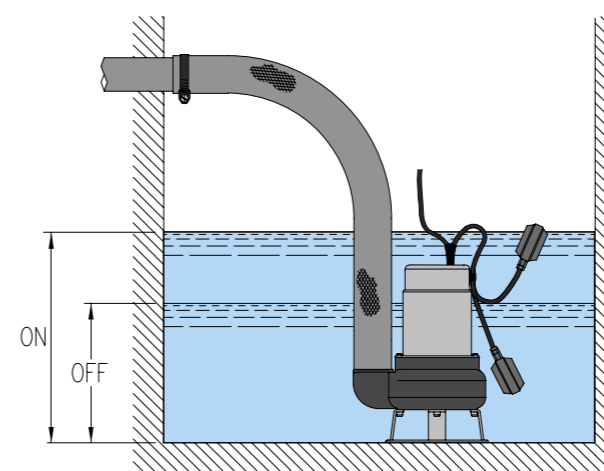
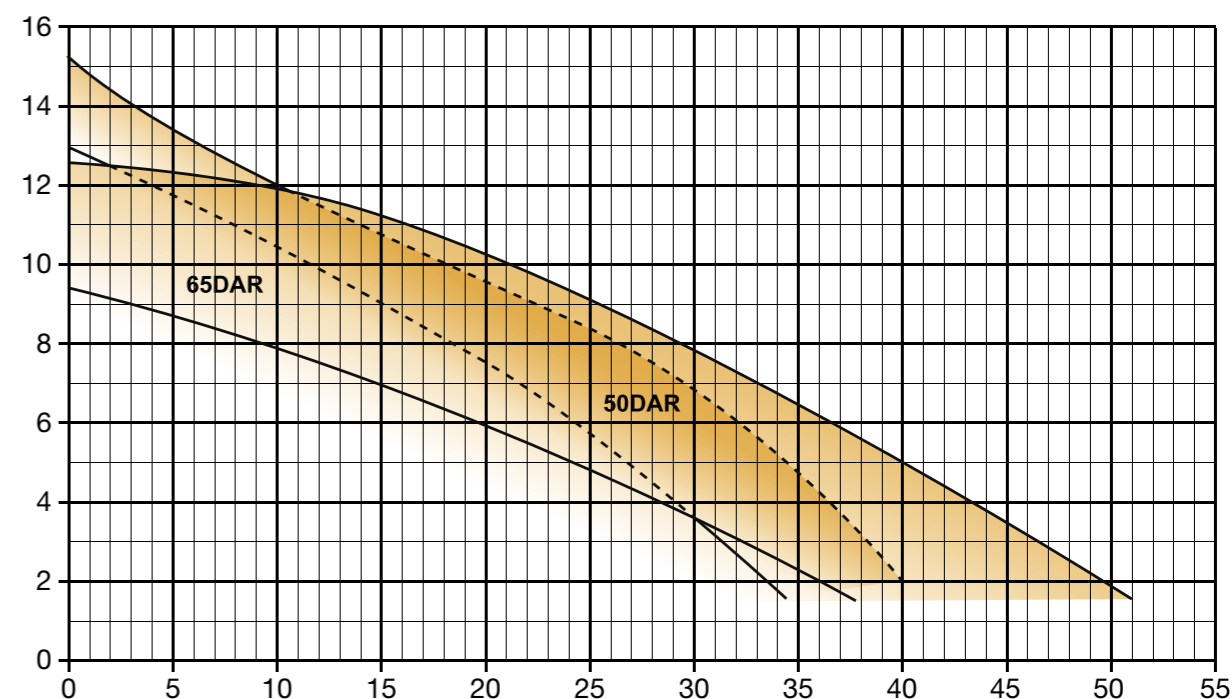

INSTALLAZIONE

The DAR electric pumps are also available with a float switch, thus increasing the versatility of use. The choice of the use of the float switch requires the respecting of minimum installation spaces to guarantee correct operation of the pump itself.

CAST IRON

Thermoprotector included or miniaturised thermal protector

Cable entry: the particular three-way vulcanisation of the power cable prevents the entry of liquids



All the clamping screws in stainless steel

Sealed bearings, lifetime lubrication, resistant to high temperatures

Double mechanical seal in an oil chamber with anti-vortex system

Dry running
The thermoprotector supplied as standard on all EBARA pumps of the D Series and the double mechanical seal with oil chamber, prevent damage from possible dry running of the pump

CAST IRON - Advanced technical solutions and high-level performance in a single name: D Series

D Series. It is the name of the EBARA submersed pumps series designed for large applications and heavy use such as sewers or large residential/industrial complexes.





Specifically conceived and designed for use with clear, meteoric or charge water, they allow the pumping of water with solid and filamentous bodies. They are distinguished by high strength and durability, and are equipped with special construction features, the true strength of the range.

The D Series name includes a wide and differentiated range of products, each of which has a very specific feature.

The DS - DSF are electric pumps with semi-open impeller used for clear or meteoric waters that can also have fibrous bodies (up to 50 mm), the DVS electric pumps, on the other hand, are used in applications with waste water thanks to the semi - vortex cast iron impeller. Also included in this range are the DL - DL W/C available in two versions, with a semi-open anti-clogging impeller (DL) and a single-channel impeller with cutting action (DL W/C). Lastly, there are the pumps suitable for waste water and with suspended solids: the DML (F) with a single-channel impeller with cutting action and the DMLV (F) which instead have a vortex impeller. DRS - DRD with two types of impellers available, the grinder type version for DRS and the multi-channel versions for the DRD electric pumps.



We offer multiple solutions

Model	DS/DSF	DVS	DRS	65DL 51,5 80DL 51,5-53,7 100dl 53,7
Number of poles	2	2	2	4
Nature of liquid	Clear waters and rainwater	Filled water with suspended solids	Filled water with solid and filamentous bodies in suspension	Filled water with solid and filamentous bodies in suspension
rpm	2850	2850	2850	1450
Impeller	Adjustment semi-open 	Anti clogging semi-vortex 	Grinder type aspiration shredder device open impeller 	Open bi-channel 
Max diameter free passages	From 5 to 10 mm	From 21 to 41 mm	From 6 to 7 mm	From 46 to 57 mm

100DL 55.5-18,5 150DL 55.5-22 200DL 55.5-22 250DL 57.5-22 300DL 511-22 80-100DLC/DLB 100DLB W/C 5,5-7,5	DL W/C (with cutter)	DML/DMLF	DMLV/DMLVF	DRD
4	4	4 (DML) 2 (DMLF)	2, 4, 6	2, 4, 6, 8
Filled water with solid and filamentous bodies in suspension	Filled water with solid and filamentous bodies in suspension	Load water with solids in suspension	Filled water with suspended solids	Filled water with suspended solids
1450	1450	1450 (DML) 2850 (DMLF)	950, 1450, 2850	2850, 1450, 950, 750
Semi-open anti-clogging. 	Open single-channel impeller with cutting action 	Single-channel impeller 	Vortex Impeller 	Bi-channel/Tri-channel impeller 
From 46 to 88 mm	From 46 to 60 mm	76 mm (DML) 30 mm (DMLF 1,1kW) 40 mm (DMLF)	From 30 to 150 mm	From 30 to 140 mm

DS – DSF

Submersible electric pumps with semi-open impeller

Submersible electric pumps with semi-open impeller for clear water and rainwater in cast iron.

Pump body, semi-open impeller, cast iron (bend) elbow. Shaft in AISI 403 (DS) and AISI 420B (DSF).

The mechanical seal is:

- SiC/SiC/NBR (impeller side)
- Carbon/Ceramic/NBR (motor side) (from 6 kW and higher for DSF)
- Upper and lower sealing ring for DS



Possibility of use in fixed and mobile installations



Filter anti-clogging.



Adjustment semi-open impeller

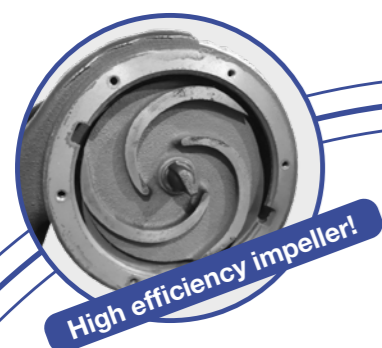

- Total head from 0.8 to 43 m
- Flow rate 5 to 84 m³/h
- Maximum liquid temperature 40°C
- Maximum solid size passage:
 - 5 mm (50DS)
 - 6 mm (65DS) (40DSF 1.5, 1.9 kW)
 - 7 mm (80DS) (40DSF 6 kW)
 - 8 mm (100DS)
- Maximum length of 50mm fibrous bodies (all DS models)

Performance curve

50Hz

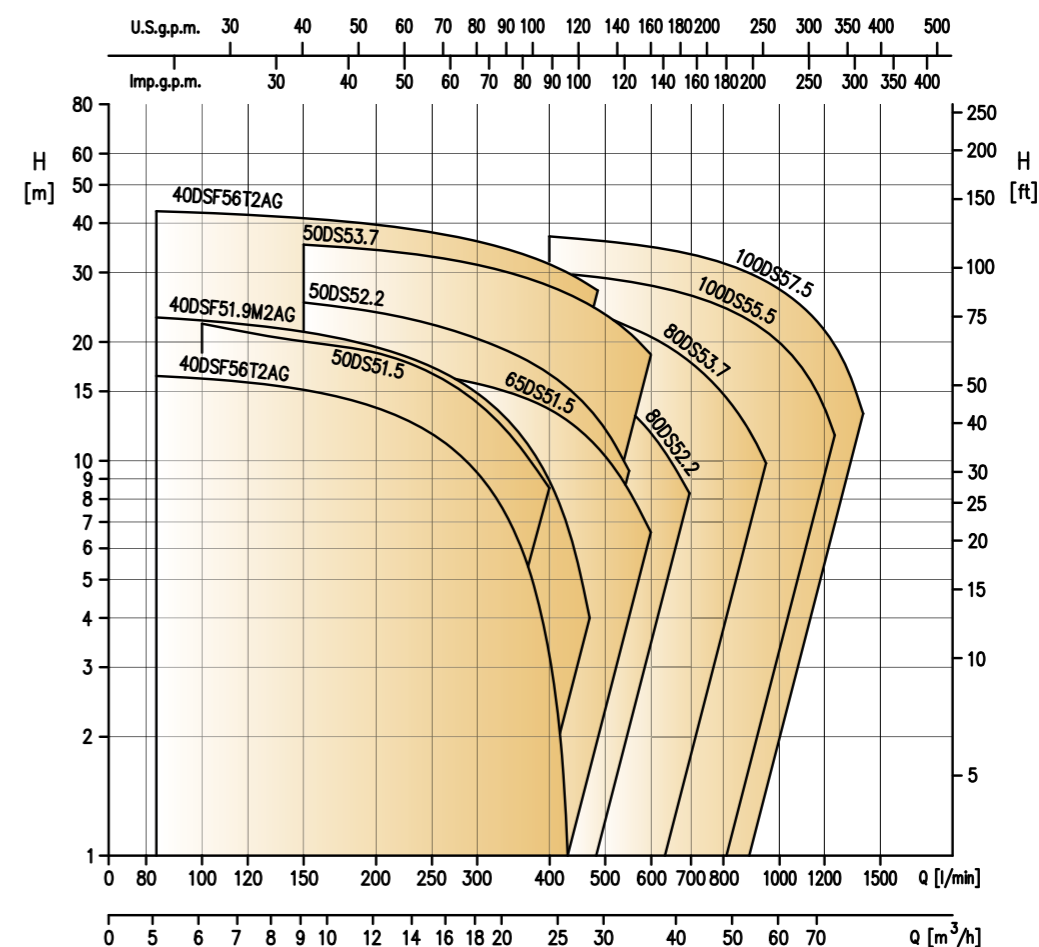

INSTALLATION

The versatility of use of DS - DSF electric pumps makes them installable in different applications: drainage tanks, rainwater lifting, emptying of basins or clear water lifting even with small parts in suspension thanks to the use of the high efficiency semi-open impeller. Moreover, among the features that make these electric pumps adaptable to the various uses, there is also the possibility of use in both fixed and mobile installations.

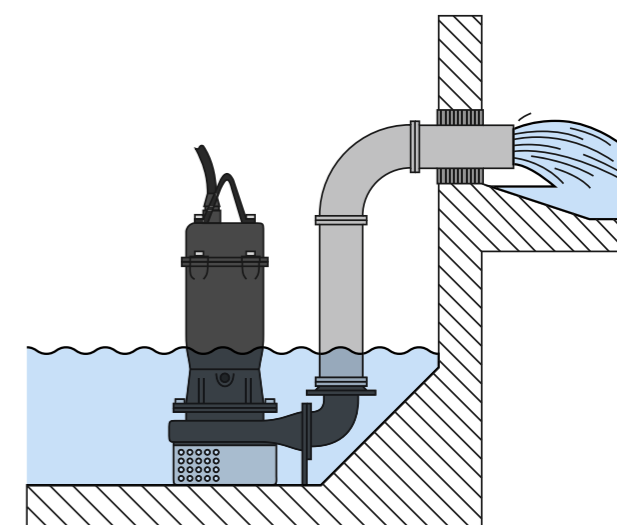

DVS

Submersible electric pumps for semi-vortex load waters

Submersible electric pump for load waters Semi-Vortex cast iron.
With pump body, semi-vortex impeller and cast iron (bend) elbow. The shaft is in AISI 403.

Mechanical seal:

- SiC/SiC/NBR (impeller side)
- Carbon/Ceramic/NBR (motor side)

Only available in three-phase version.

- Total head from 5.3 to 23 m
- Capacity from 6 to 60 m³/h
- Maximum liquid temperature 40°C
- Maximum solid size passage:
 - 21 mm (50DVS)
 - 33 mm (65DVS and 80DVS 1.5 kW)
 - 41 mm (65DVS and 80DVS 2.2, 3.7 kW)
- Maximum length of fibrous bodies:
 - 100 mm (50 DVS)
 - 200 mm (65DVS and 80DVS 1.5 kW)
 - 245 mm (65DVS and 80DVS 2.2, 3.7 kW)



Adjustment semi-open impeller



Semi vortex impeller anti-clogging.



The anti-clogging semi vortex impeller of the DVS allows the pumping **foreign bodies with dimensions up to 70%** of the outlet diameter of the outlet opening



Performance curve

50Hz

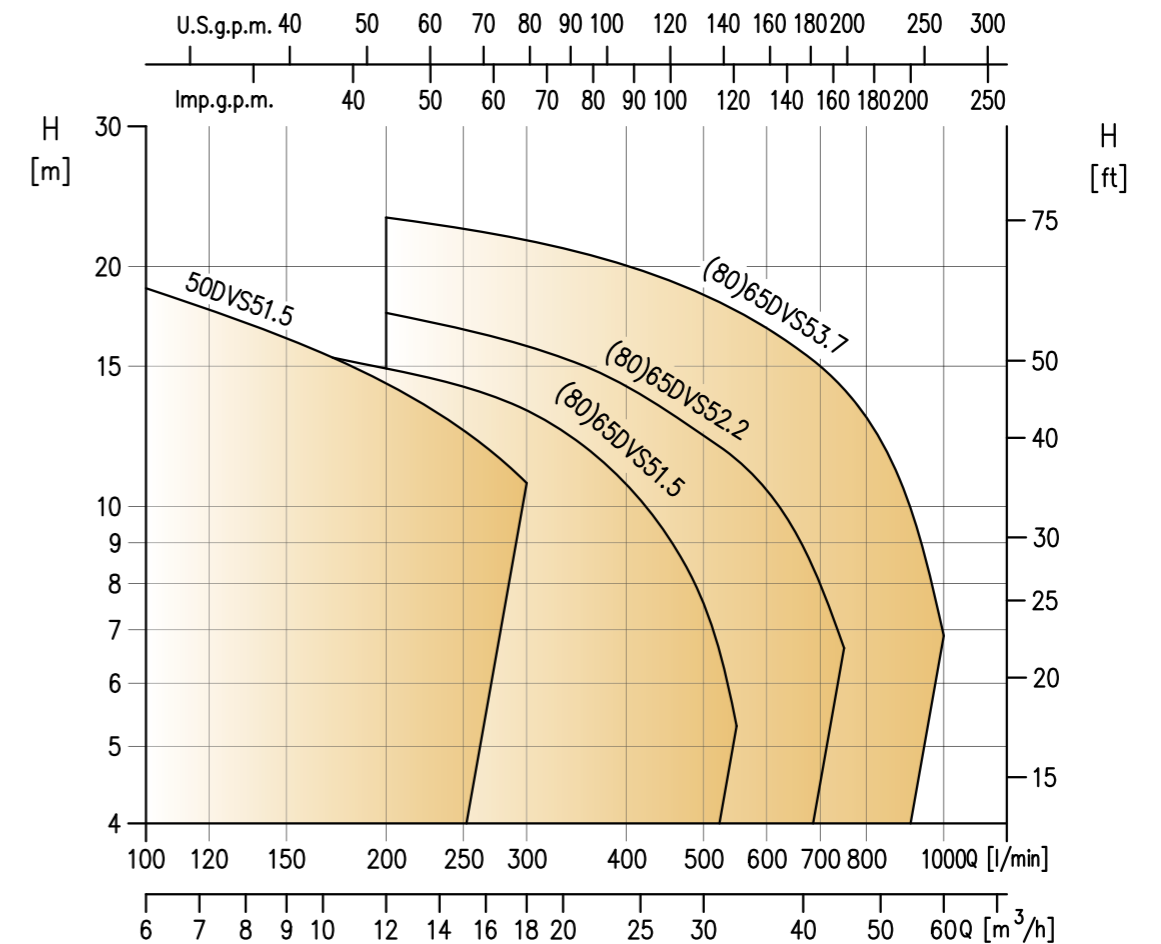

INSTALLATION

The high technical characteristics of the DVS electric pumps make them installable in applications with waste water such as, for example, sewage collection tanks, clear or grey water lifting containing soft or fibrous solids, use in septic tanks or grey water lifting with suspended parts. All this thanks to the use of the anti-clogging semi vortex impeller. Moreover, non-secondary aspect, they are electric pumps that do not require demanding maintenance or frequent checks.

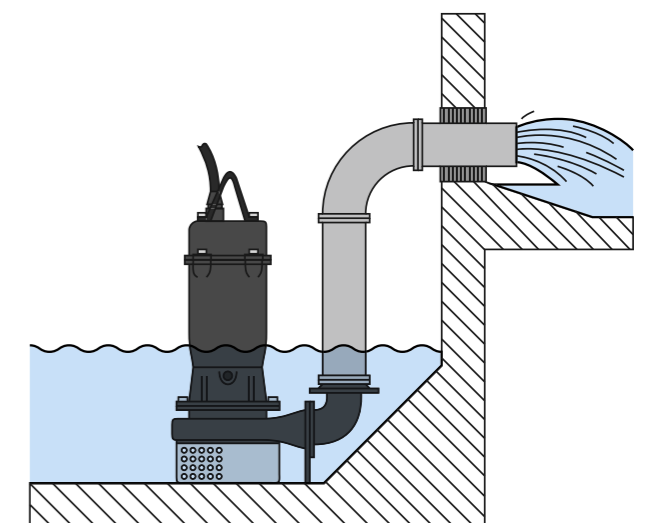

DL – DL W/C

Submersible electric pumps for sewage (DL) with cutter (DL W/C)

Submersible electric pump for waste water in cast iron. Version with cutter (DL W/C). Pump body, impeller, cast iron elbow (curve). Shaft in AISI 403.

Mechanical seal:

- SiC/SiC/NBR (impeller side)
- Carbon/Ceramic/NBR (motor side)

Only available in three-phase version.

Wide range available with diameter of 300 mm and from 65 to 300 mm and power up to 45 kW (DL)



Open bi-channel impeller



Possibility of use in fixed and mobile installations



Impeller open single-channel with cutting action



Semi-open anti-clogging impeller



- Total head from 3 to 43.5 m for DL and from 4 a 20.2 m for DL W/C
- Capacity from 4 to 780 m³/h for DL and from 6 a 150 m³/h for DL W/C
- Maximum solid size passage:
 - 35 mm (65DL)
 - 50 mm (80DL, all DLC)
 - 60 mm (100DL, 100DLB)
 - 70 mm (150DL up to 22kW)
 - 76 mm (200DL up to 22kW)
 - 76 mm (all 30÷45 kW)
 - 82 mm (250DL up to 22kW)
 - 90 mm (300DL up to 22kW)
- Maximum liquid temperature 40°C
- Maximum length of fibrous bodies:
 - 195 mm (65DL)
 - 240 mm (80DL, all DLC)
 - 300 mm (100DL, 100DLB)
 - 400 mm (150DL up to 22kW)
 - 500 mm (200DL up to 22kW)
 - 500 mm (all 30÷45 kW)
 - 550 mm (250DL up to 22kW)
 - 600 mm (300DL up to 22kW)

Performance curve

50Hz

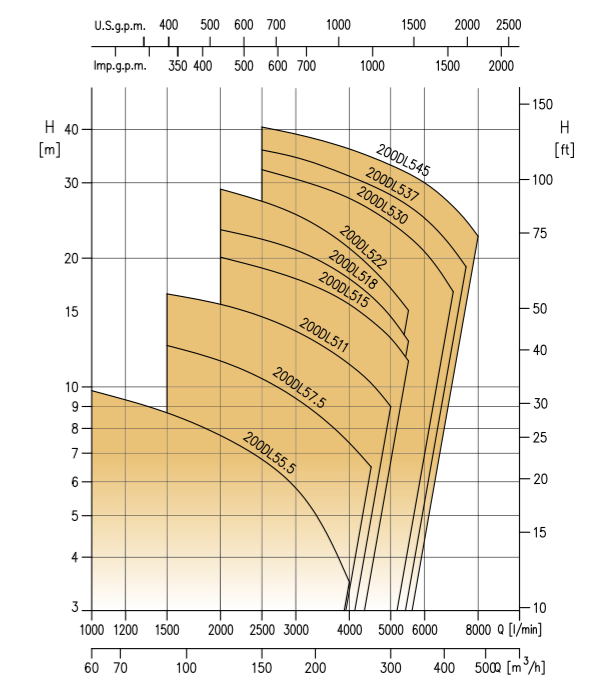
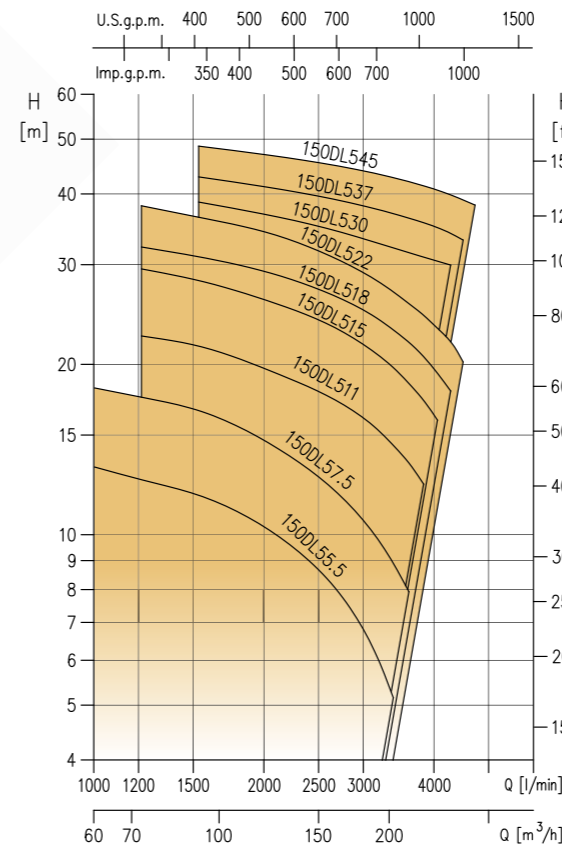
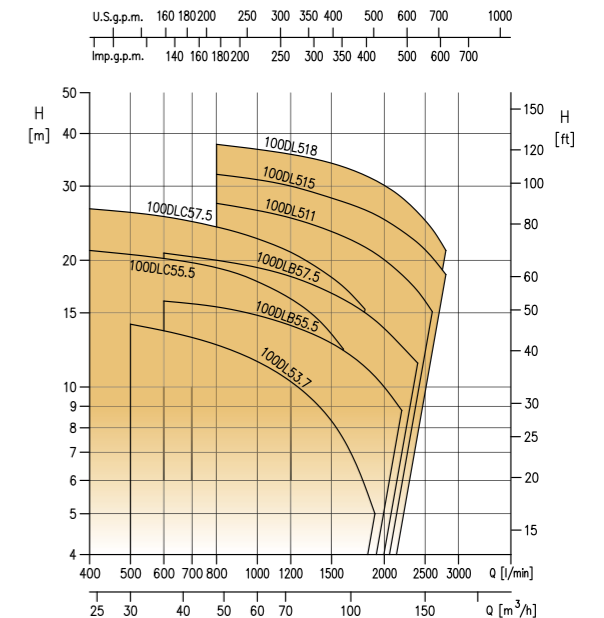
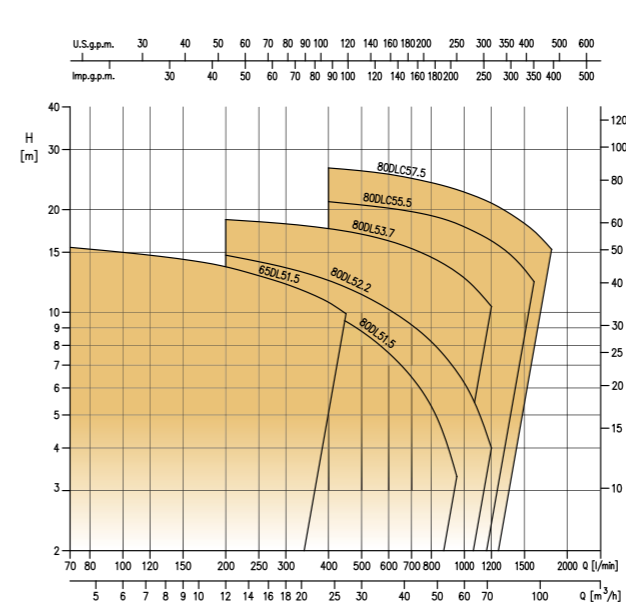

Performance curve

50Hz

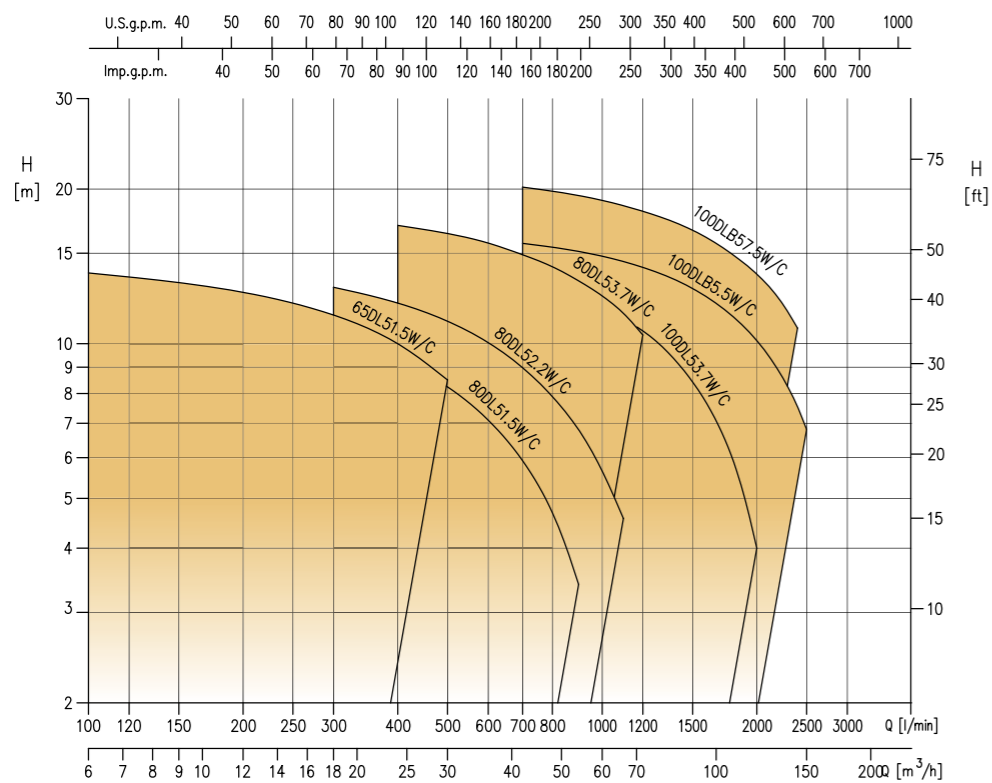
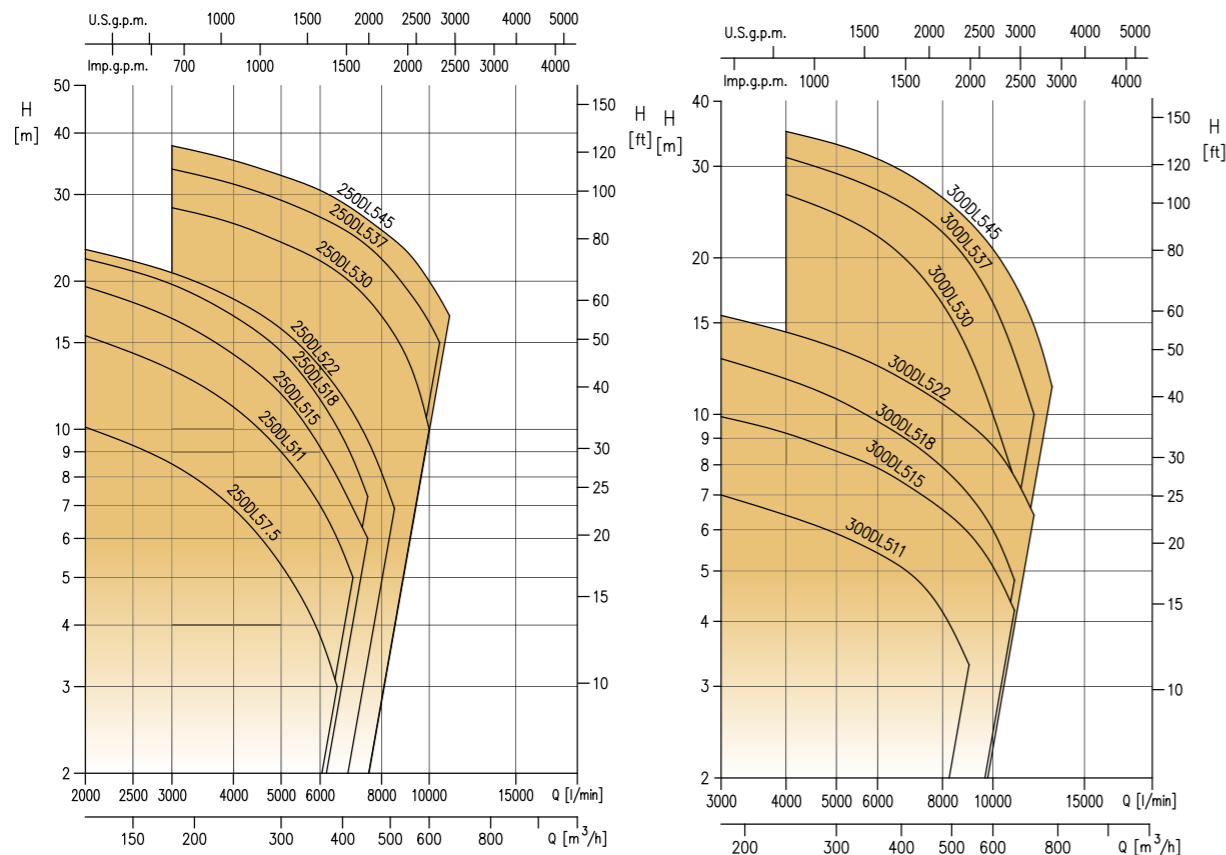

DML(F) - DMLV(F)

Submersible electric pumps with single-channel impeller (DML-DMLF) or with vortex impeller (DMLV-DMLVF) cast iron, for sewage.

Pump body, single-channel impeller, cast iron (bend) elbow. The shaft is in AISI 403 for DML-DMLV and in AISI 420B for DMLF-DMLVF.

Mechanical seal:

- SiC/SiC/NBR (pump side) for DML and DMLF
- Carbon/Ceramic/NBR (motor side) for DML and DMLF
- SiC/SiC/NBR (pump side) for DMLV and DMLVF
- Carbon/Ceramic/NBR (motor side) for DMLV and DMLVF



Open single-channel impeller with cutting action



Impeller vortex



Semi-open anti-clogging impeller



Possibility of use in fixed and mobile installations



- Total head from 4 to 38.5 m for DML
from 2.4 to 16.5 m for DMLF
from 1.4 to 41.3 m for DMLV(F)
- Capacity from 12 to 330 m³/h for DML
from 7 to 45 m³/h for DMLF
from 12 to 200 m³/h for DMLV(F)
- Maximum liquid temperature 40°C
- Maximum solid size passage:
 - 76 mm (DML)
 - 30 mm (DMLF up to 1,4 kW)
 - 40 mm (DMLF)
 - 80 ÷ 100 mm (DMLV)
 - 30 ÷ 80 mm (DMLVF)
- Maximum length of fibrous bodies 400 mm for 80DMLV, 500 mm for 100DMLV and 40 mm for DMLF

Performance curve

50Hz

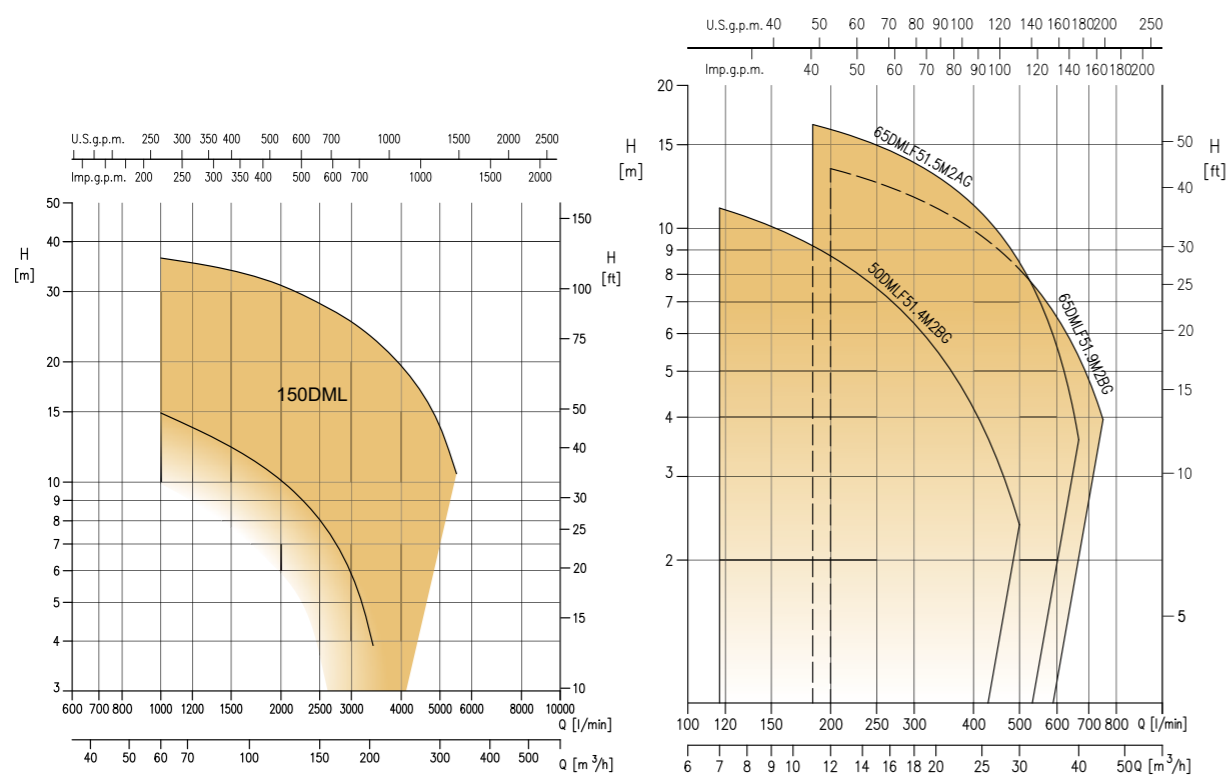
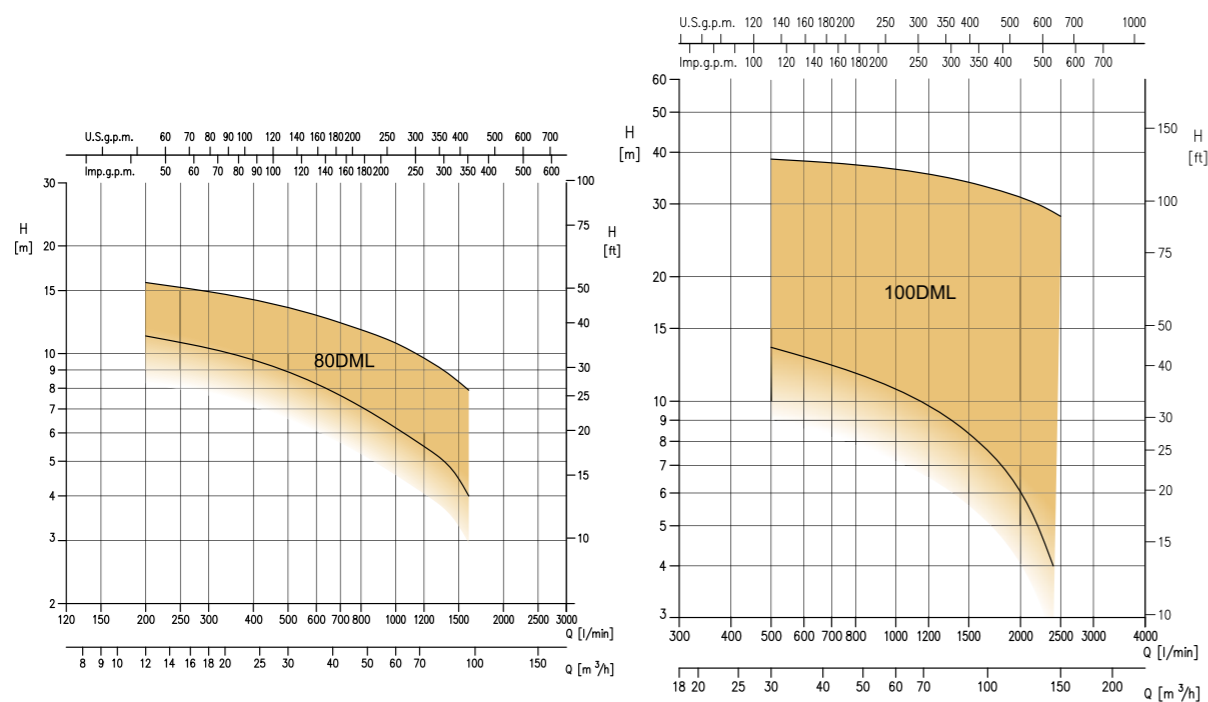

Performance curve

50Hz

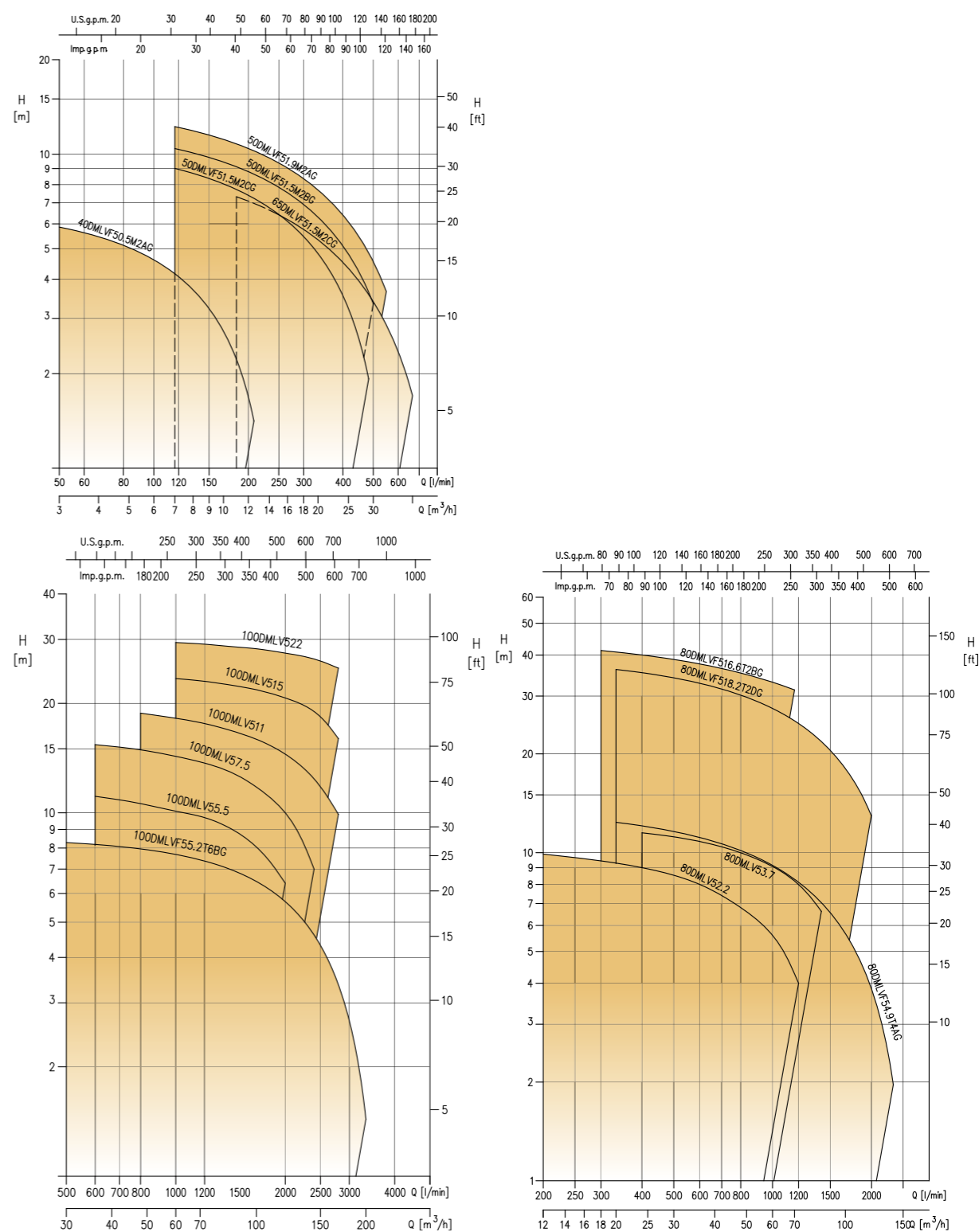

DRS - DRD

Submersible electric pump for sewage with grinder type impeller (DRS) or multi-channel impeller (DRD)

Pump body, impeller, motor case, volute bottom and cast iron top cover. Grinding device in AISI 304 for DRS, with multi-channel cast iron impeller for DRD. Shaft in AISI 420B.

Mechanical seal:

- SiC/SiC/NBR (pump side)
- Carbon/Ceramic/NBR (motor side)



Grinder type shredder adjustment open impeller



Impeller multi-channel DRD



Possibility of use in fixed and mobile installations



- Total head from 0.6 to 72 m for DRS from 0.8 to 57 m for DRD
- Capacity from 4.5 to 60 m³/h for DRS from 12 to 1800 m³/h for DRD
- Maximum liquid temperature 40°C
- Maximum passage of solids 6 ÷ 7 mm for DRS 40, 8 ÷ 10 mm for DRS 65, 30 ÷ 140 mm for DRD

Performance curve

50Hz

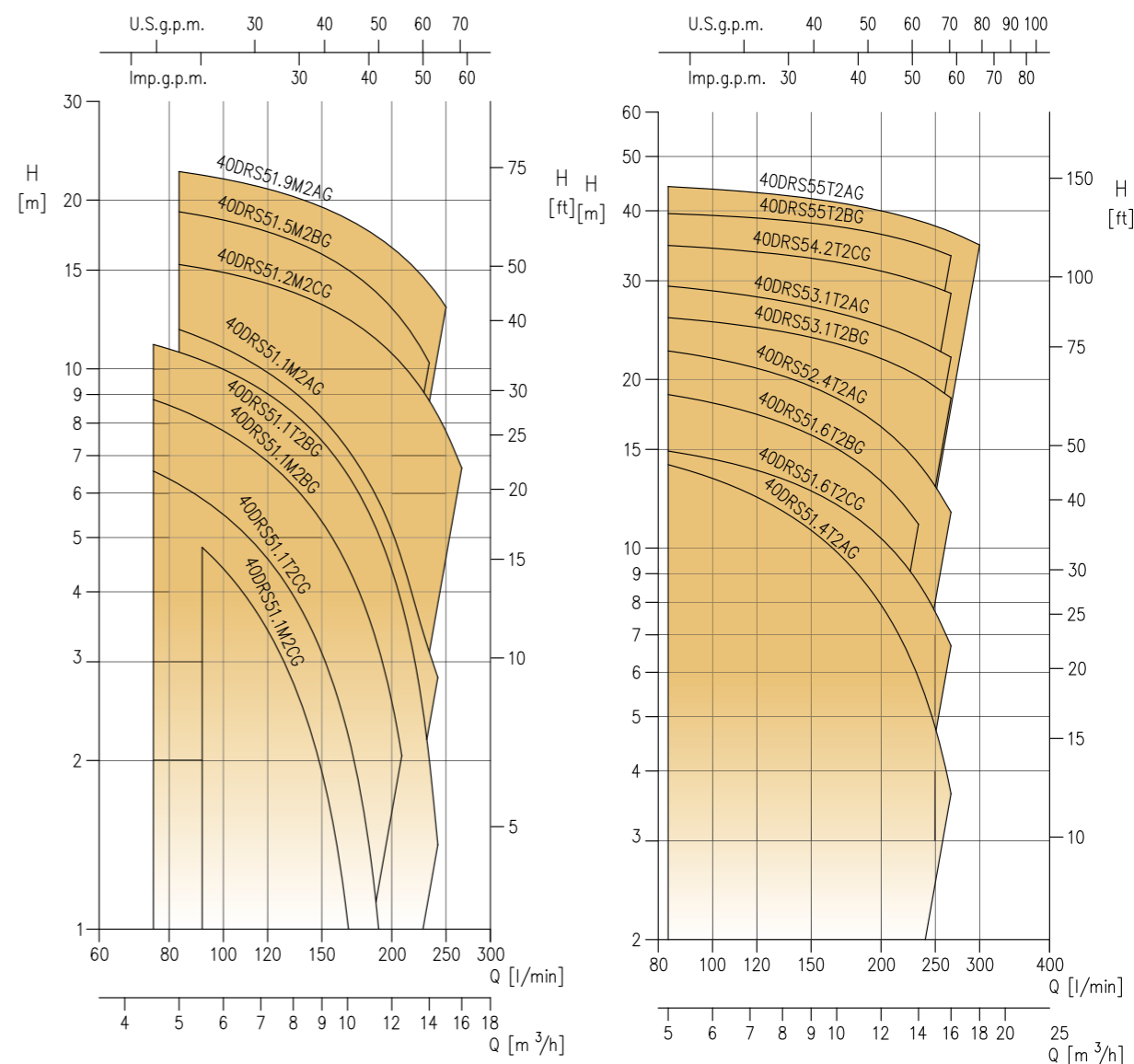

Performance curve

50Hz

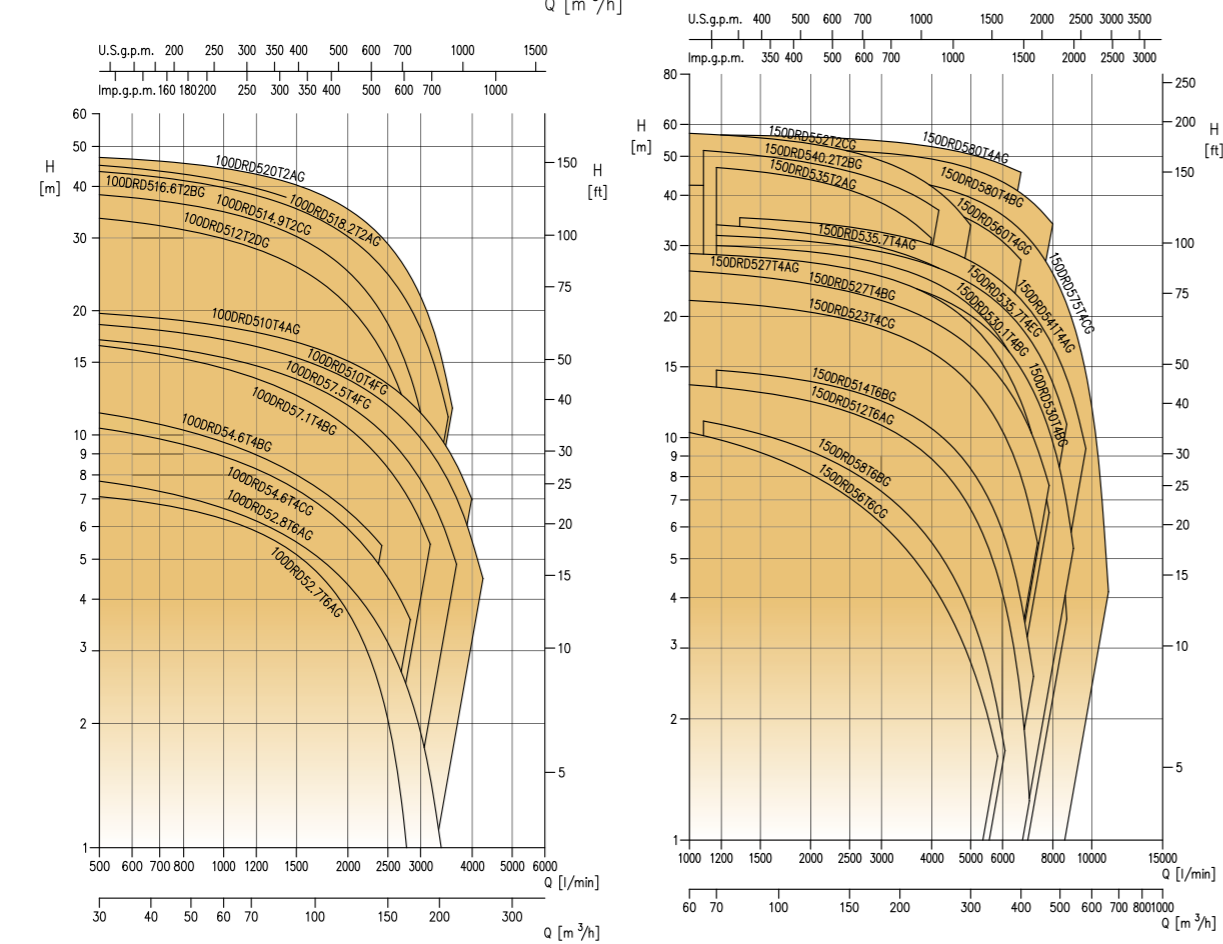
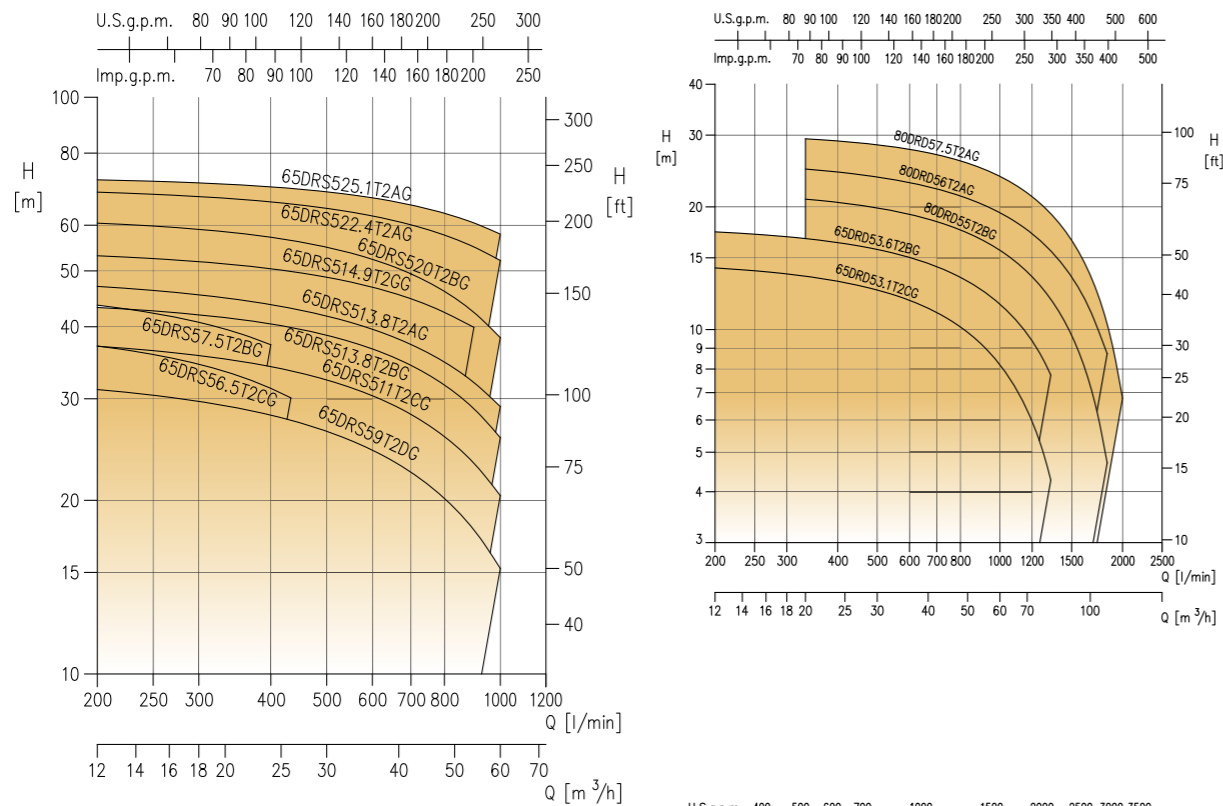

Performance curve

50Hz

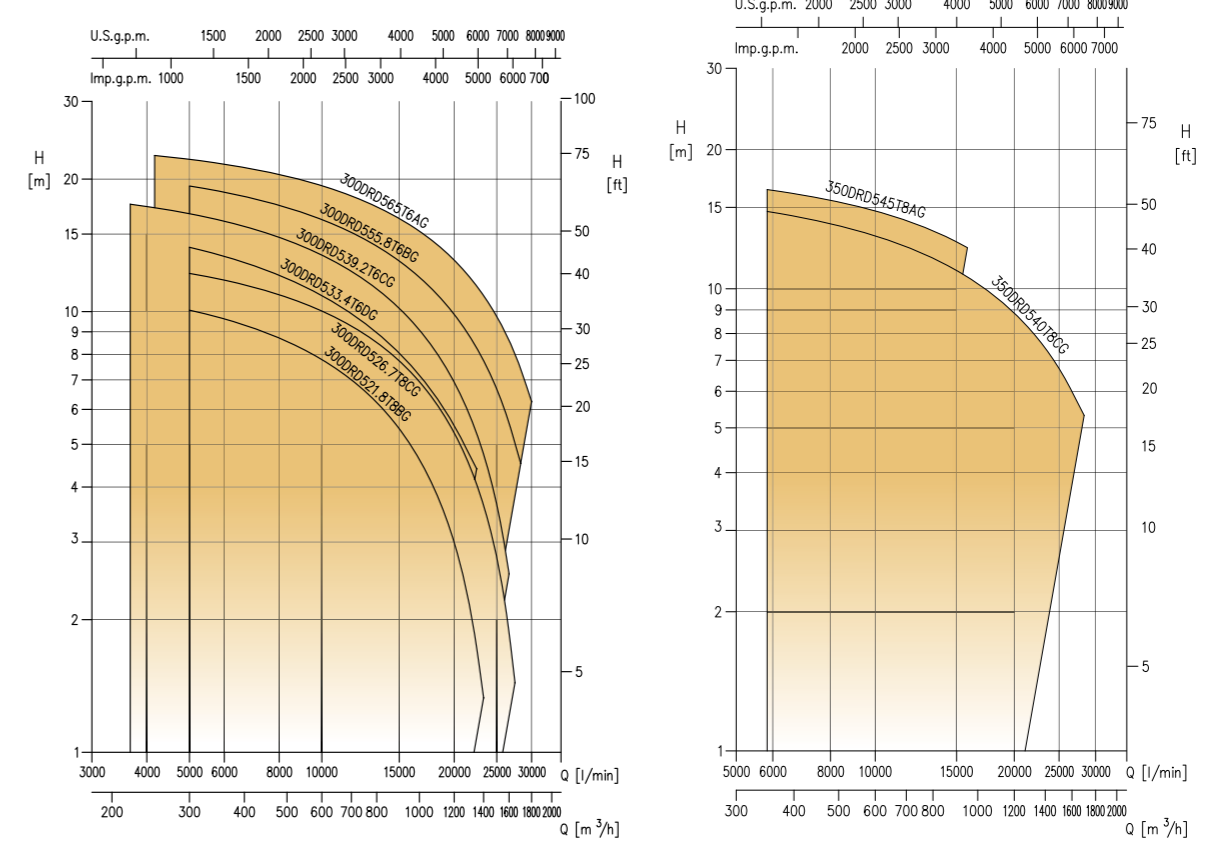
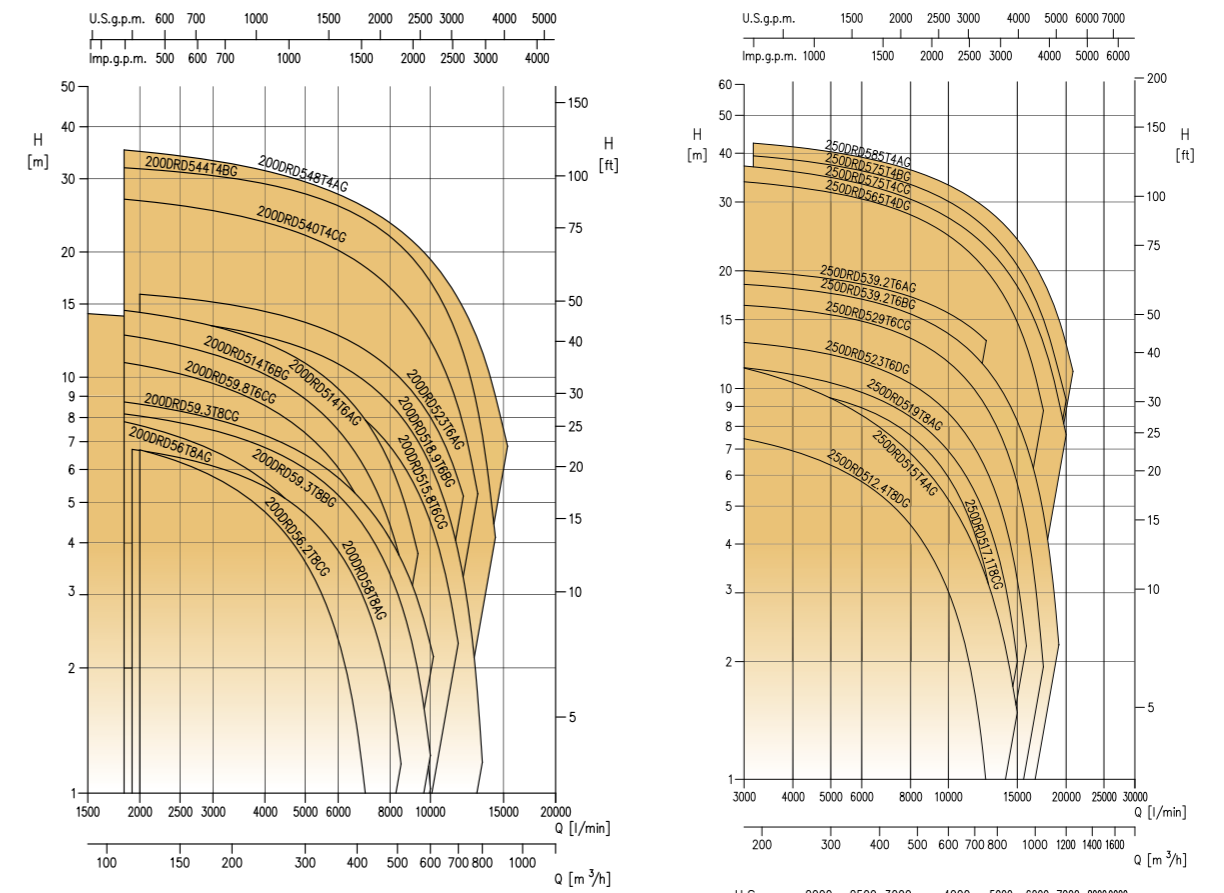

D-TANK

Waste water collection tanks

Waste water collection tanks characterised by a sturdy construction, ease of installation and equipped with a fast passage curve. Polyethylene tank of 100, 200 and 600 litres complete with cover with expanded EPDM gasket and stainless steel AISI 304 bolts. Available in the basic version and in the "E" version.



D-TANK 600 (E)



D-TANK 200 (E)



D-TANK 100 (E)

BEST BOX

Lifting stations

Lifting stations characterised by a robust construction, ease of installation, available with or without electric pump.

BEST BOX L: ideal for lifting water for domestic and bathroom use (sink, dishwasher, washing machine)

BEST BOX D: particularly suitable for shower water, it does not need to be buried thanks to the tank inlet positioned 90 mm from the bottom and to a non-return device

BEST BOX G: rainwater lifting, from washing areas, garage descent, etc.



BEST BOX D



BEST BOX G

Accessories

EBARA not only provides electric pumps, but aims to be a **complete partner** for anyone using pumping systems. Being full partners means providing not only electric pumps but also a range of **complementary products** for installation. This takes on even more significance for the D Series submersed pumps range, where the installation requires special accessories. Among those that EBARA offers are the **descent slide kit** (QDC), the **adapters for JIS/DIN flanges**, the **guide hook** and the **descent slide adapter** 2 guide tubes.



Furthermore, **EBAMIX**, submersed mixers, complete the range. These **mixers** are used for the mixing, homogenization and agitation of heavy sludge and liquids containing solid particles and for the removal of background deposits.

EZ-finder, more than just a simple selector

EZ-finder, a way to look for a model of electric pump?? **Much more.**

It is the ultimate tool to find and select the right product for your needs.

Thanks to the logic of the selector, it is possible to search for a product in **various ways**: according to the point of work, by entering the model name or by selecting the application type. **Simple**, the right product in seconds.

EZ-finder is the **ideal tool** available to the installer, the designer or the engineer.

Discover it at the link <https://ezfinder.ebara.com>



Everything that you need just a click away

visit our website www.ebara.eu



Data book

Complete technical documentation to be consulted to obtain all the data related to the pumps



Instruction manual

The manual with all the information needed for correct installation of our pumps



Kensaku

a system for the selection of spare parts



Ez-finder

The correct pump selection software for every need
<https://ezfinder.ebara.com>



Service

A team of professionals at your disposal to advise you in your choice of pump and to offer post sale assistance

EBARA sales network

EUROPE

EBARA Pumps Europe S.p.A.
Via Torri di Confine 2/1 int. C
36053 Gambellara (Vicenza), Italy
Phone +39 0444 706811
Fax +39 0444 405811
www.ebaraurope.com

Italian Sales (for order only):
e-mail: ordini@ebaraurope.com

Export Sales (for order only):
e-mail: exportsales@ebaraurope.com

Technical Customer Service (TCS):
e-mail: tcs@ebaraurope.com
Phone +39 0444 706869/902/923/833

Marketing:
e-mail: marketing@ebaraurope.com

EBARA Pumps Europe S.p.A. GERMANY
Elisabeth-Selbert-Straße 2
63110 Rodgau, Germany
Phone +49 (0) 6106-660 99-0
Fax +49 (0) 6106-660 99-45
e-mail: info@ebara.de

EBARA Pumps Europe S.p.A. UNITED KINGDOM
Unit A, Park 34
Collett Way - Didcot
Oxfordshire - OX11 7WB, United Kingdom
Phone +44 1895 439027 - Fax +44 1235 815770
e-mail: mktguk@ebaraurope.com

EBARA Pumps Europe S.p.A. FRANCE
555, Rue Juliette Recamier
69970 Chaponnay, France
Phone +33 4 72769482
Fax +33 805101071
e-mail: mktgfr@ebaraurope.com

EBARA POMPY POLSKA Sp. z o.o.
ul. Działkowa 115 A
02-234 Warszawa, Poland
Phone +48 22 3909920
Fax +48 22 3909929
e-mail: mktgpl@ebaraurope.com

EBARA Pumps RUS Ltd.
Prospekt Andropov 18, building 7, floor 11
115432 Moscow
Phone +7 499 6830133
e-mail: mktgrus@ebaraurope.com

EBARA PUMPS IBERIA, S.A.
Poligono Ind. La Estación
C/Cormoranes 6-8
28320 Pinto (Madrid), Spain
Phone +34 916.923.630
Fax +34 916.910.818
e-mail: marketing@ebara.es

MIDDLE EAST

EBARA Pumps Middle East FZE
P.O. BOX 61383
Jebel Ali, Dubai, UAE
Phone +971 4 8838889
Fax +971 4 8835307
e-mail: info@ebarame.ae

EBARA PUMPS SAUDI ARABIA LLC
St. 98, Dammam Second Industrial City, P.O.Box.
9210,
Dammam 34333, Kingdom of Saudi Arabia
Phone 966-138022014

ASIA AND SOUTH-EAST ASIA

EBARA Corporation
11-1, Haneda Asahi-cho, Ohta-ku,
Tokyo 144-8510, Japan
Phone +81 3 3743-6111
Fax +81 3 5736 3100
www.ebara.co.jp

EBARA Corporation Fujisawa plant
4-2-1, Hon-Fujisawa, Fujisawa-shi.
Kanagawa 251-8502, Japan
Phone +81-466-83-8111
Fax +81-466-81-2164

EBARA Machinery (CHINA) CO., Ltd.
Room No.303, Beijing Fortune Plaza, No.7
Dongsanhuan Zhong Road, Chaoyang District
Beijing, 100020 P. R. China
Phone 86-10-65309996
Fax 86-10-6530-8968
e-mail: emc@ebare.cn
www.ebara.cn

EBARA Densan (Qingdao) Technology Co., Ltd.
No.88, Wangsha Road, Chengyang Qingdao,
Shandong Province, P.R.China
Phone 86-532-8965-3382
Fax 86-532-8965-3379
www.edq-ebara.com

EBARA-Densan Taiwan Manufacturing Co., Ltd.
No.7, Nan-Yuen 2nd Road, Chung Li City,
Tao Yuen Hsien, Taiwan
Phone 886-3-451-5881
Fax 886-3-452-7904
www.ebara.com.tw

EBARA Thailand Limited
3rd Floor Achme Build. 125 Phetchburi Road
Tungphayathai, Rajthevee, Bangkok 10400, Thailand
Phone 66-2-216-4935
Fax 66-2-216-4937
e-mail: info@ebara.co.th
www.ebara.co.th/index.php/en/

EBARA Fluid Machinery Korea Co., Ltd.
3rd Fl. Hyun-Seok Tower, 50,
Seolleung-Ro 93-Gil, Gangnam-Gu
Seoul, 135-513 Korea
Phone 82 70 43621100
Fax 82 70 82302030
e-mail: nishikura.ryutaro@efmk-ebara.com

EBARA Pumps Philippines, Inc.
Canlubang Industrial Estate,
Cabuyao 4025, Laguna, Philippines
Phone 0063-49-549-1806
Fax 0063-49-549-1915
e-mail: marketing@ebaraphilippines.com
www.ebaraphilippines.com.ph

P.T. EBARA Indonesia
Jl. Raya Jakarta - Bogor Km. 32
Desa Curug, Cimanggis-Depok
Jawa Barat, 16953 Indonesia
Phone (62-21) 874 0852-53
Fax (62-21) 874 0033
e-mail: marketing@ebaraindonesia.com
www.ebaraindonesia.com

EBARA Pumps Malaysia Sdn. Bhd
6, Jalan TP3, UEP Subang Jaya Industrial Park,
47620, Subang Jaya, Selangor, Malaysia.
Phone 603-8023 6622
Fax 603-8023 9355
e-mail: sales@ebara.com.my
www.ebara.com.my

EBARA Engineering Singapore Pte. Ltd.
No 1, Tuas Link 2, Singapore 638550
Phone 65-6862-3536
Fax 65-6861-0589
e-mail: stdpump@ebrnet.com.sg
www.ebara.com.sg

EBARA MACHINERY INDIA PRIVATE LIMITED
#133, 1st Floor, Velachery Main Road, Guindy,
Chennai 600 032, India
Phone 91-755-0089388

EBARA Vietnam Pump Company Limited
Lai Cach Industrial Zone, Lai Cach Town,
Cam Giang District,
Hai Duong Province, Vietnam
Tel 84-2203-850182
Fax 84-2203-850180
e-mail: info@evpc-vn.com
www.ebarapump.com.vn/en/

AMERICA

EBARA PUMPS AMERICAS CORPORATION
1651 Cedar Line Drive
Rockhill, South Carolina 29730 U.S.A.
Phone 803 327-5005
Fax 803 327-5097
e-mail: info@pumpsebara.com
www.pumpsebara.com

**EBARA Industrias Mecanicas
& Comercio Ltda. (Brazil)**
Rua Joaquim Marques de Figueiredo, 2-31,
Distrito Industrial, CEP 17034-290, Bauru, SP, Brazil
Phone +55 14 4009-0000
Fax +55 14 4009-0044
e-mail: assistencia@ebara.com.br
www.ebara.com.br/ebara/pt/index.php

Thebe Bombas Hidraulicas S.A.
Avenida Manoel Gomes Casaca, 840 Parque Industrial,
Vargem Grande do Sul City, Sao Paulo State, CEP:
13.880-970, Brazil
Phone 55-19-3641-9100
Fax 55-19-3641-9114
www.thebe.com.br

EBARA Bombas Colombia S.A.S.
Autopista Medellin km 7 Celta Trade Park Bodega
02 Lote 116 Funza. Republica de Colombia
Phone 57-1-826-9865

AFRICA

EBARA PUMPS SOUTH AFRICA (PTY) LTD
26 Kyalami Boulevard, Kyalami Business Park,
1684, Midrand, Gauteng
South Africa
Phone: +27 11 466 1844
Fax: +27 11 466 1933

OCEANIA

EBARA Pumps Australia Pty. Ltd.
7, Holloway Drive
Bayswater 3153 Victoria, Australia
Phone 0061-3-97613033
Fax 0061-3-97613044
e-mail: berrett@ebara.com.au
sales@ebara.com.au
www.ebara.com.au/index.html



EBARA Pumps Europe S.p.A.

Via Torri di Confine 2/1 int. C
36053 Gambellara (Vicenza), Italy
Phone +39 0444 706811
Fax +39 0444 405811
ebara_pumps@ebaraeurope.com
www.ebaraeurope.com

EBARA Corporation

11-1, Haneda Asahi-cho, Ota-ku,
Tokyo 144-8510
Japan
Phone +81 3 6275 7598
Fax +81 3 5736 3193
www.ebara.com

