

Water Boosters with One Pump

SUPERDAF SERIES



TECHNICAL MANUAL



SUPERDAF Series

Water Boosters with One Pump

General Specifications



Mas Grup

Application Areas

- Apartments and houses
- Schools, business districts and small industrial facilities

Advantages – Mounting and Start-Up

- SUPERDAF Series pumps are a set of booster containing a vertical, multistage centrifugal pump and in which the motor is mounted on the pump.
- Stage number of the pump is from 4 up to 10.
- Completely stainless steel material option is available.
- Modular type with expansion tank.
- The control switch is provided safety and regularly operation of the booster. It does not require electrical panel.
- It is ready to connection to monophase socket by power cable with plug included in the delivery.
- Sealing is provided by mechanical seal.
- The level floater preventing waterless working, the quiet operated check-valve, the baseplate and the rubber feet preventing vibration are included in the delivery.
- The suction nozzle of the booster should be under from the level of water reservoir and water should reach to pump by its own weight. In different situations, please consult to MAS DAF Makine San. A.Ş.
- Suction line selecting in same diameter with suction nozzle as minimum should connect to booster evenly and as shortest; a strainer and a valve should be used on the suction line.
- Installation loads should not be put in booster.
- The level floater included in delivery should be hung down to the reservoir and by setting it should be fixed.
- Before working of booster, the pump and suction line should be filled with water and its air should be drained.

Standard Material Specifications

Pump Casing	: GG 25
Pump Shaft	: AISI 304
Pump Impeller	: Noryl
Pump Seal	: Mekanik

Technical Specifications

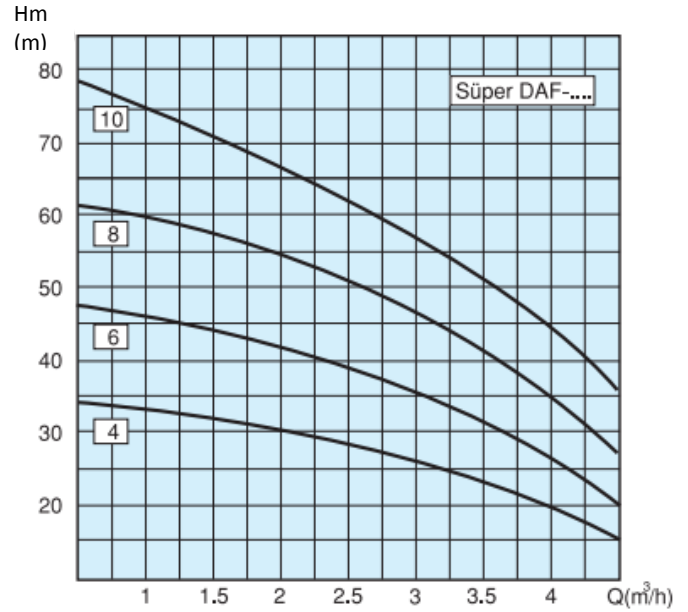

- Capacity Range : 0 - 4 m³/h
- Head Range : 78 m
- Operating Pressure : 8 Bar
- Motor Speed Range : 2900 – 3600 rpm
- Suction Flange : 1 ¼"
- Discharge Flange : 1 ¼"

SUPERDAF Series

Water Boosters with One Pump

Technical Specifications



Mas Grup

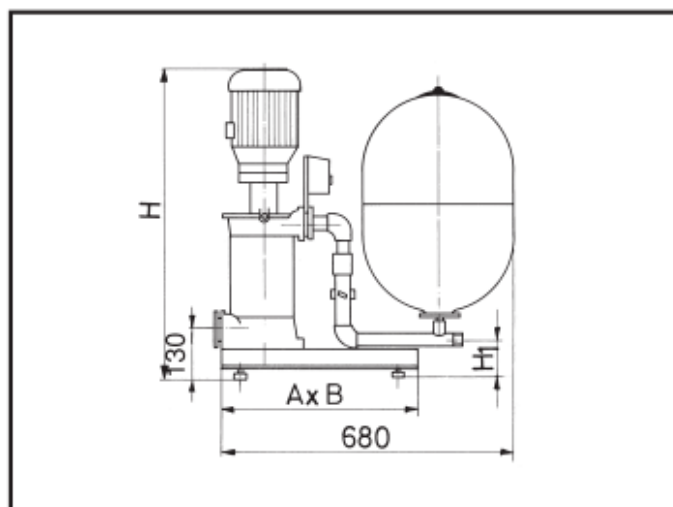

Booster Type	Motor Power (kW)*	Max. Capacity (m ³ /h)	Max. Pressure (m)	Dimensions			
				A	B	H	H1
SUPERDAF-4	0.55	4	34	450	275	652	115
SUPERDAF-6	0.75	4	47	450	275	742	115
SUPERDAF-8	1.1	4	61	450	275	807	115
SUPERDAF-10	1.5	4	78	450	275	905	115
Tank Volume	50 lt.						
Connection (Suction – Discharge)	1 ¹ / ₄ " – 1 ¹ / ₄ "						
Working Temperature	60° C (Max.)						

* Electric motors are 380 V/3 phase/50 Hz.



Mas Grup

Head Office / Service Center:

Aydınlı Mah. Birlik OSB. 1.No'lu Cadde No:17 Tuzla - İSTANBUL / TURKEY
Tel: +90 (216) 456 47 00 pbx Fax: +90 (216) 455 14 24

Ankara Regional Directorate:

Aşağı Öveçler Mah. 1329 Sok. No:6/9 Öveçler ANKARA / TURKEY
Tel: +90 (312) 472 81 60-67 Fax: +90 (312) 472 82 51

Factory:

1. Organize Sanayi Bölgesi Parsel 249/5 Beyköy - DÜZCE / TURKEY
Tel: +90 (380) 553 73 88 Fax: +90 (380) 553 71 29