

RELY ON EXCELLENCE

## M2N

Mechanical seals | Mechanical seals for pumps | Pusher seals



### Features

- For plain shafts
- Single seal
- Unbalanced
- Conical spring rotating
- Dependent on direction of rotation

### Advantages

- Economical seal solution
- No damage of the shaft by set screws
- Short installation length possible (G16)

### Operating range

Shaft diameter:  
d1 = 6 ... 38 mm (0.25" ... 1.5")  
Pressure: p1 = 10 bar (145 PSI)  
Temperature:  
t = -20 °C ... 140 °C  
(-4 °F ... 355 °F)  
Sliding velocity:  
vg = 15 m/s (50 ft/s)  
Axial movement: ±1.0 mm

### Materials

Seal face: Carbon graphite resin impregnated (B)  
Seat G9: Silicon carbide (Q1, Q2), Special cast CrMo steel (S), Aluminium oxide (V)

### Standards and approvals

- EN 12756

### Recommended applications

- Pulp and paper industry
- Water and waste water technology
- Building services industry
- Water pumps
- Heating circulation pumps

## RELY ON EXCELLENCE

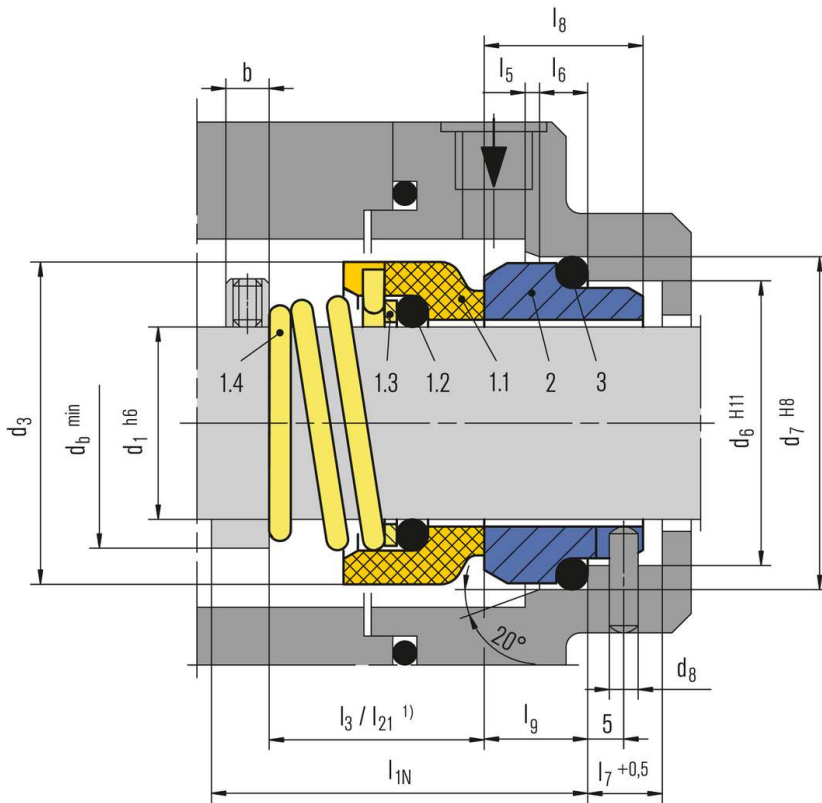

Item	Part no. to DIN 24250	Description
1.1	472	Seal face
1.2	412.1	O-Ring
1.3	474	Thrust ring
1.4	478	Righthand spring
1.4	479	Lefthand spring
2	475	Seat (G9)
3	412.2	O-Ring

RELY ON EXCELLENCE

## Seat alternatives

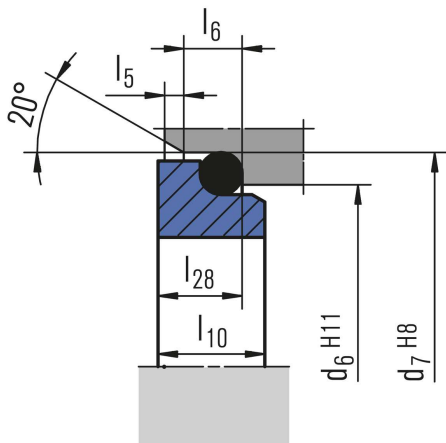

G6 (EN 12756)

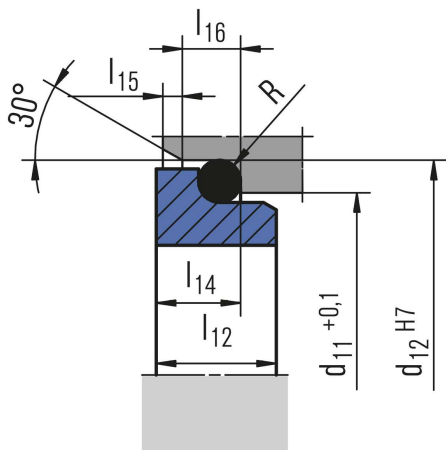

G4

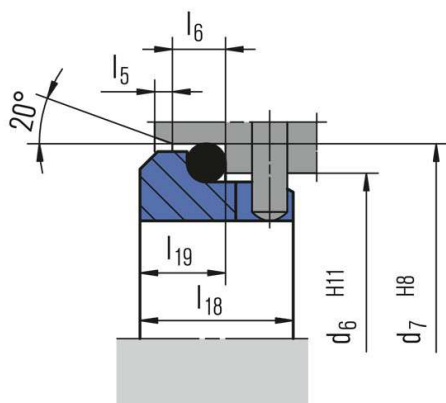

G16 (EN 12756)

## RELY ON EXCELLENCE

### Product variants

#### M2

Rotating unit M2 with seat G4 or G16 (shorter installation length).

Seal face:

Carbon graphite resin impregnated (B)

Seat G4:

Silicon carbide (Q1), Special cast CrMo steel (S)

Seat G16:

Silicon carbide (Q1, Q2), Special cast CrMo steel (S), Aluminium oxide (V)

#### M2N4

Rotating unit M2 with seat G6.

Seal face:

Carbon graphite resin impregnated (B)

Seat G6:

Silicon carbide (Q1), Special cast CrMo steel (S)

### Dimensions

d <sub>1</sub>	d <sub>3</sub>	d <sub>6</sub>	d <sub>7</sub>	d <sub>8</sub>	d <sub>11</sub>	d <sub>12</sub>	d <sub>b</sub>	d <sub>b</sub>	l <sub>3</sub> <sup>1)</sup>	l <sub>5</sub>	l <sub>6</sub>	l <sub>7</sub>	l <sub>8</sub>	l <sub>10</sub>	l <sub>12</sub>	l <sub>14</sub>	l <sub>15</sub>	l <sub>16</sub>	l <sub>18</sub>	l <sub>19</sub>	l <sub>21</sub> <sup>1)</sup>	l <sub>28</sub>	b	R
6	15	-	-	-	11.8	16.0	8	-	-	-	-	-	-	-	6.5	5.6	1.2	3.8	-	-	10.9	-	-	1.2
8	18	-	-	-	15.5	19.2	11	-	-	-	-	-	-	-	8.0	7.0	1.2	3.8	-	-	15.5	-	-	1.2
10	20	17	21	3	15.5	19.2	13	40	17.5	1.5	4	8.5	17.5	7.5	7.5	6.6	1.2	3.8	-	-	15.9	6.6	8	1.2
12	22	19	23	3	17.5	21.6	16	40	17.5	1.5	4	8.5	17.5	7.5	8.0	7.0	1.2	3.8	-	-	16.0	6.6	8	1.2
14	25	21	25	3	20.5	24.6	18	40	17.5	1.5	4	8.5	17.5	7.5	8.0	7.0	1.2	3.8	-	-	16.0	6.6	8	1.2
15	27	-	-	-	20.5	24.6	19	-	-	-	-	-	-	-	7.5	6.6	1.2	3.8	-	-	17.4	-	-	1.2
16	27	23	27	3	22.0	28.0	21	40	19.5	1.5	4	8.5	17.5	7.5	8.5	7.5	1.5	5.0	-	-	19.0	6.6	8	1.5
18	30	27	33	3	24.0	30.0	23	45	20.5	2.0	5	9.0	19.5	8.5	9.0	8.0	1.5	5.0	15	7	20.5	7.5	8	1.5
20	32	29	35	3	29.5	35.0	26	45	22.0	2.0	5	9.0	19.5	8.5	8.5	7.5	1.5	5.0	15	7	22.0	7.5	8	1.5
22	35	31	37	3	29.5	35.0	28	45	23.5	2.0	5	9.0	19.5	8.5	8.5	7.5	1.5	5.0	15	7	23.5	7.5	8	1.5
24	38	33	39	3	32.0	38.0	30	50	25.0	2.0	5	9.0	19.5	8.5	8.5	7.5	1.5	5.0	15	7	25.0	7.5	8	1.5
25	40	34	40	3	32.0	38.0	31	50	26.5	2.0	5	9.0	19.5	8.5	8.5	7.5	1.5	5.0	15	7	26.5	7.5	8	1.5
26	41	-	-	-	34.0	40.0	32	-	-	-	-	-	-	-	9.0	8.0	1.5	5.0	-	-	26.5	-	-	1.5
28	43	37	43	3	36.0	42.0	35	50	26.5	2.0	5	9.0	19.5	8.5	10.0	9.0	1.5	5.0	15	7	26.5	7.5	8	1.5
30	47	-	-	-	39.2	45.0	37	-	-	-	-	-	-	-	11.5	10.5	1.5	5.0	15	7	25.0	-	-	1.5
32	48	-	-	-	42.2	48.0	39	-	-	-	-	-	-	-	13.0	10.5	1.5	5.0	15	7	28.5	-	-	1.5
35	53	-	-	-	46.2	52.0	43	-	-	-	-	-	-	-	13.5	11.0	1.5	5.0	15	7	28.5	-	-	1.5
38	56	-	-	-	49.2	55.0	47	-	-	-	-	-	-	-	13.0	10.3	1.5	5.0	16	8	32.0	-	-	1.5

Dimensions in Millimeter

1) l<sub>3</sub> valid for M2N, l<sub>21</sub> valid for M2