

Product Description	Technical Features	Operating Range	Material
<ul style="list-style-type: none"> ▶ 1,1-Seal face ▶ 1,2-O-Ring (For rotary seal) ▶ 1,3-Housing ▶ 1,4-O-Ring ▶ 1,5-Spring ▶ 2-Stationary Seat ▶ 3-O-Ring (For stationary seal) 	<ul style="list-style-type: none"> ▶ Single Seal ▶ Unbalanced ▶ Dependent of rotation direction 	<ul style="list-style-type: none"> ▶ $d_1 = 14 - 150\text{mm}$ ▶ $p = 10\text{ bar}$ ▶ $t = -50 / 220\text{ }^\circ\text{C}$ ▶ $V_g = 20\text{ m/sn}$ 	<ul style="list-style-type: none"> ▶ Rotary seal faces: Carbon, Silicon carbide, Tungsten Carbide ▶ Stationary seal faces: Silicon carbide, Ceramic, Tungsten Carbide, Chromuim Nickle 316 ti ▶ Elastomers : Viton (FKM), EPDM, Nitril (NBR) Silicon
Stationary Seat Alternatives			
		▶ G-9 G-4	

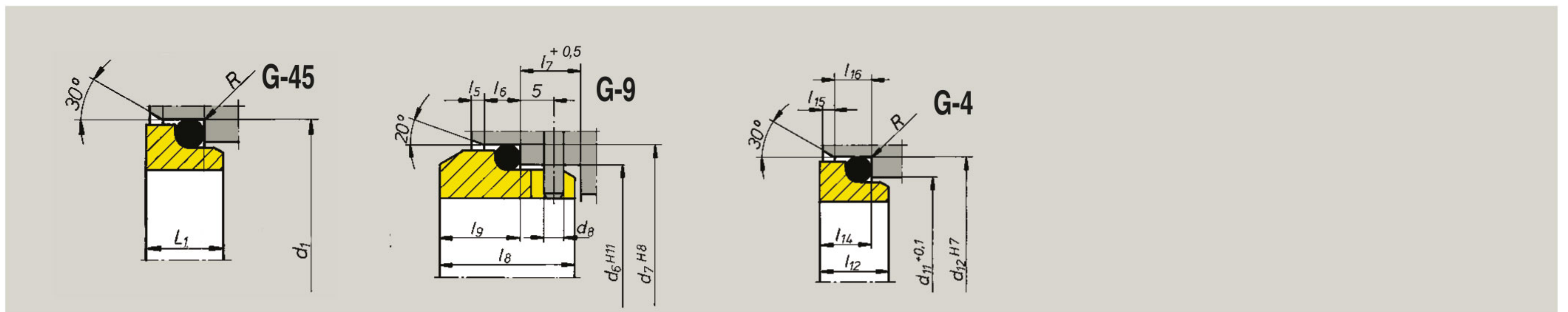

d	L	D1	L1	d	L	D1	L1
14	27	23,1	6	45	51	65,5	11,5
15	27	26,9	7	48	51	65,5	11,5
16	28	26,9	7	50	55	72,5	11,5
18	30	30,9	8	55	57	72,5	11,5
19	30	30,9	8	60	61	79,3	11,5
20	30	30,9	8	65	63	84,5	11,5
22	30	35,4	8	70	63	89,5	11,5
24	32	35,4	8	75	68	94,5	11,5
25	33	38,2	8,5	80	70	99,5	11,5
28	36	43,3	9	85	72	105,5	13,5
30	37	43,3	9	90	75	111,5	13,5
32	37	43,3	9	95	75	116,5	13,5
33	48	53,5	11,5	100	85	119,5	13,5
35	48	53,5	11,5	110	89	132,2	17,5
38	48	60,5	11,5	120	97	142,2	17,5
40	48	60,5	11,5	130	108	153,2	17,5
42	48	60,5	11,5	140	110	164,3	18,5
43	48	60,5	11,5	150	120	174,2	18,5