



Standardized Chemical Pumps to EN 22858/ISO 2858/ISO 5199

Automation products available:

- PumpExpert
- PumpDrive (MM)
- Hyamaster
- hyatronic

Fields of Application

For handling aggressive organic and inorganic fluids in the chemical and petrochemical industries.

They are also used in: refinery off-sites, the paper and cellulose industries, the foodstuffs industry, the sugar industry, sea water desalination plants, absorption equipment in environmental engineering, power stations, etc.

Design

Horizontal, radially split volute casing pump in back pull-out design, with radial impeller, single-entry, single-stage, to EN 22 858/ISO 2858/ISO 5199.

Complemented by pumps of DN 25, DN 200 and above.

Designation

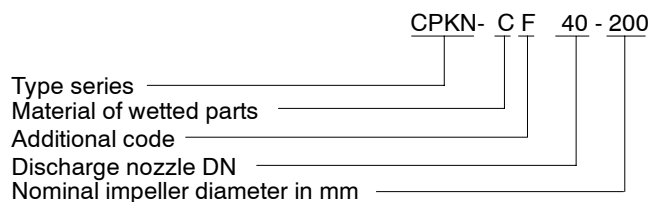

Additional codes:

- H = Heated model
- O = Open impeller
- F = Off-standard flange design
- K = Intensively cooled shaft seal chamber
- X = Special design

Operating Data

Capacity	Q	up to	4150 m ³ /h (1150 l/s)
Heads	H	up to	185 m
Pump sizes	DN		25 to 400
Operating pressures	p	up to	25 bar
Operating temperatures	t		-40 to +400 °C
Operating temperatures	t		-40 to +400 °C

Certification

Certified quality management ISO 9001.

Selection Charts

n = 2900 rpm

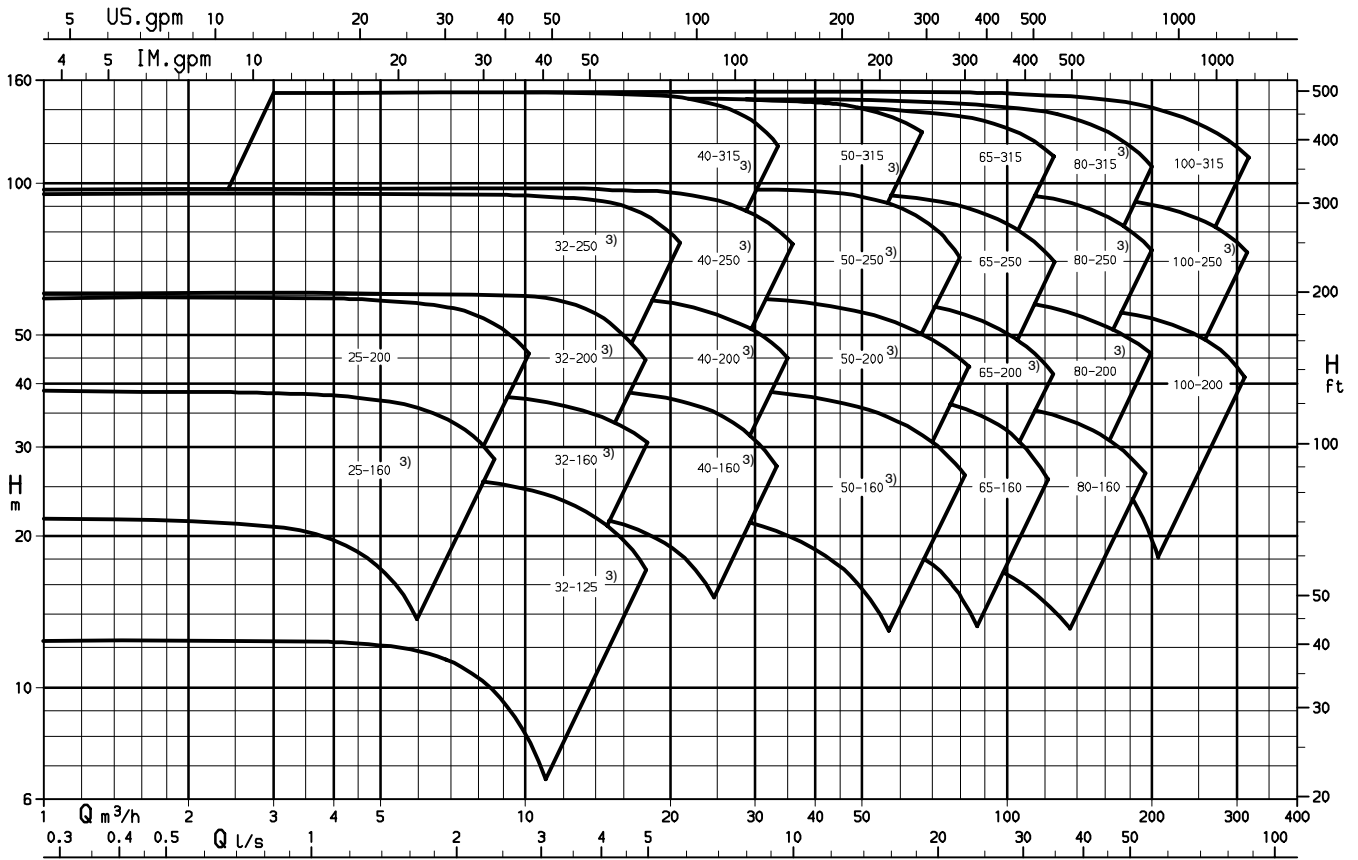

n = 1450 rpm

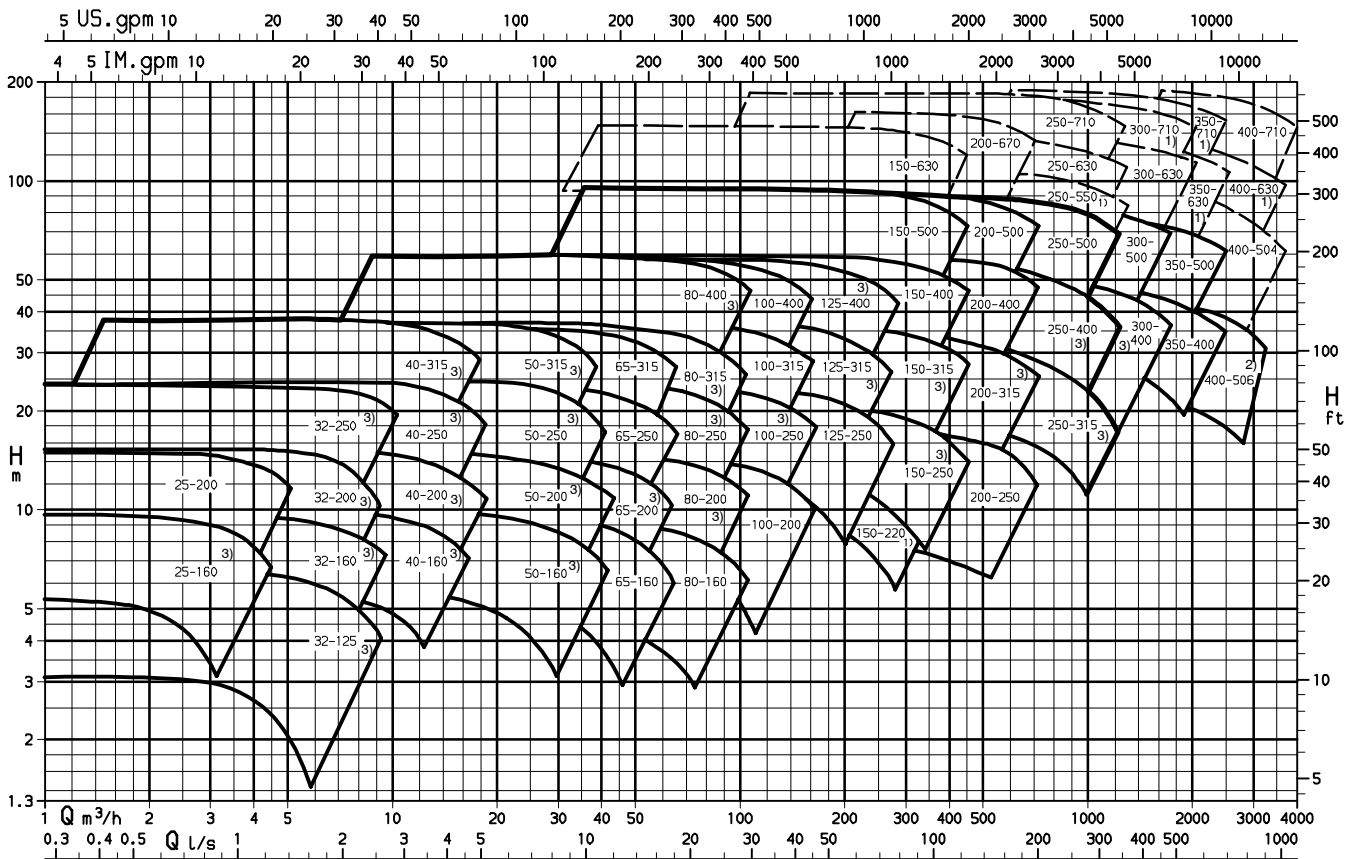

- 1) on request
- 2) n = 960 rpm
- 3) heated model "-CH" possible

Pressure and Temperature Limits

a) Where no special regulations apply (technical codes)

These pumps can be used for all fluids, except for hot water and organic heat transfer fluids.

Material variants S1 and S2

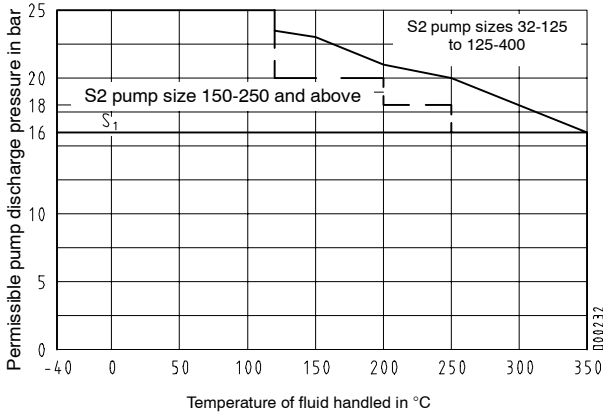

Material variants C1, C3 and E

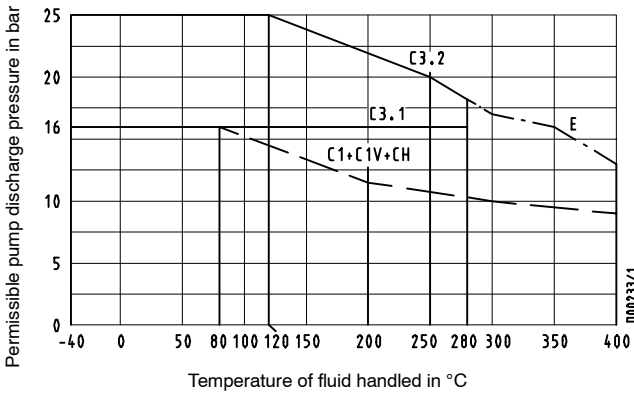

b) Hot water applications

This applies to pumps not installed in hot water generation plants, i.e. pumps which are not subject to the regulations valid for such applications.

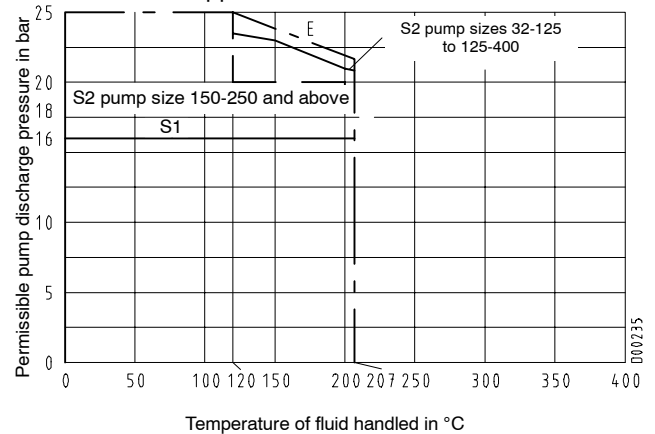

c) Where special regulations apply

In case of special regulations, different safety factors are required, which usually leads to a reduction of the limits stated in a).

Information about the revision of the application limits has to be requested for each individual case, stating the acceptance specifications.

d) Heated model, CPKN-CH

Design	Heated by			
	Hot water/ saturated steam		Thermal oil	
	t _{max}	P _{max}	t _{max}	P _{max}
Lantern (344) JL1040 ¹⁾ O-ring (412.01)- material EPDM	183 °C	10 bar	--	--
Lantern (344) JS1025 ²⁾ O-ring (412.01)- material PTFE/alloyed steel	250 °C	20 bar ⁴⁾	300 °C	6 bar
Welded casing cover	300 °C	20 bar ⁴⁾	300 °C	6 bar

1) except for pump sizes 250-315, 80-400 and 200-400:
P_{max} = 12 bar, for higher pressures please contact KSB.

e) Pressure and temperature limits for shaft seals

The application limits of shaft seals depend on the circumferential speed, the material and the fluid handled. They have to be checked in each individual case on the basis of the manufacturer's documentation, taking into account the actual operating conditions.

Materials ¹⁾

Part description	Material variant - standard programme			
	C1/C1.V ²⁾ / CHs ²⁾	S1/S2	E	C3.1/C3.2
Volute casing	1.4408	JS1025 ³⁾	GP240GH+N	Noridur 1.4593
Casing cover	1.4408	GP240GH+N / JS1025 ⁴⁾	GP240GH+N ⁴⁾	Noridur 1.4593
Support foot	S235JRG2 ⁵⁾	S235JRG2 ⁵⁾	S235JRG2 ⁵⁾	S235JRG2 ⁵⁾
Shaft	C 45+N ⁶⁾	C 45+N ⁶⁾	C 45+N ⁶⁾	C 45+N ⁶⁾
Impeller	1.4408	JL1040 ⁷⁾⁸⁾	JL1040 ⁷⁾⁸⁾	Noridur 1.4593
Bearing bracket	JL1040 ⁸⁾	JL1040 ⁸⁾	JL1040 ⁸⁾	JL1040 ⁸⁾
Bearing bracket lantern	JL1040 ⁸⁾⁹⁾	JL1040 ⁸⁾⁹⁾	JL1040 ⁸⁾⁹⁾	JL1040 ⁸⁾⁹⁾
Seal cover	1.4571	1.4571	1.4571	1.4539
Casing wear ring	-	JL1040 ⁸⁾	-	-
Shaft protecting sleeve - gland packing	1.4571	1.4122	1.4122	1.4539
Shaft protecting sleeve - mechanical seal ¹⁰⁾	1.4571	1.4571	1.4571	1.4539
Impeller nut	1.4571	1.4571	1.4571	1.4539

1) Special materials available, depending on the fluid handled

2) C1.V in compliance with VDMA 24276

3) EN 1563: GJS-400-18-LT

4) for pump design with conical seal chamber: P250GH

5) from bearing bracket UP05 JS1030

6) for wet shaft or
T < -10 °C: 1.4462
T < -40 °C: 1.5680
T > 250 °C: 1.7709VS

7) on bearing bracket UP04: JS1025
at T > 350 °C or circumferential speed > 48 m/sec: 1.4408

8) EN 1561: GJL-250

9) for hot water > 183 °C, for organic heat transfer fluid > 200 °C, for all T > 350 °C and if special regulations apply: JS1025 (EN 1563: GJS-400-18-LT)

10) not fitted on wet shaft

Benefits at a Glance

Reliable
thanks to well-proven hydraulic system

Easy to replace
thanks to standardized design and flange variants

Universal
installation chamber for standardized and cartridge-type mechanical seals

Reduced shaft deflection
due to reinforced shaft with or without shaft protecting sleeve

Reliable operation
due to sturdy bearing assembly and oil lubrication; Bearing life of more than 25,000 operating hours

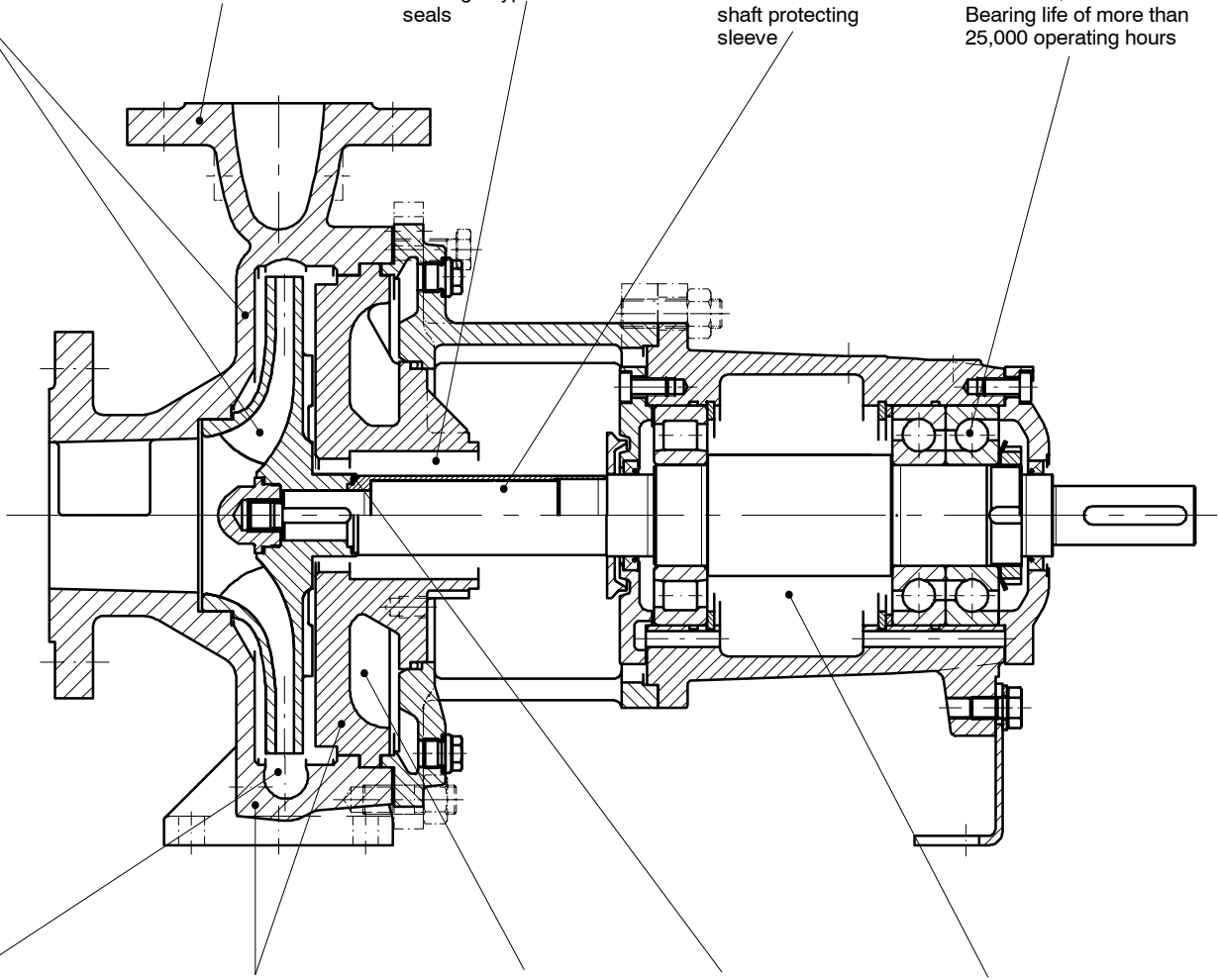

Long service life
of bearings and mechanical seals due to low radial forces

Small stock of spare parts
due to the modular design system

Wide variety of applications
due to a wide range of pump materials and many variants, e.g. cooled discharge cover

Safety
thanks to impeller attachment with metal-to-metal contact

Easy maintenance
due to constant-level oiler: constant lubrication, easy to check

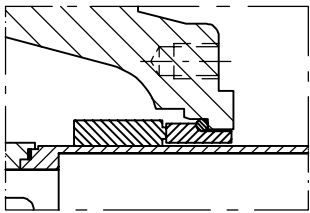

D00458

Conical seal chamber (A-type cover)

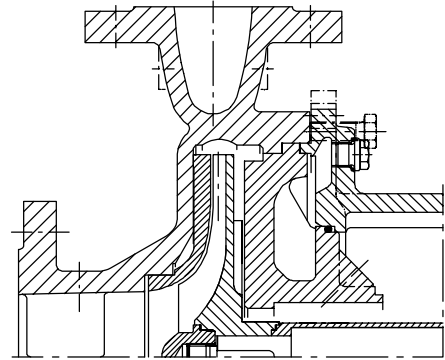

001165

Model with open impeller (CPKNO)

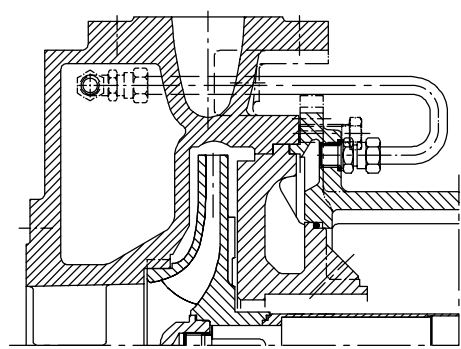

001166

Heatable model (CPKN-CHs)

Technical Data

Pumps on bearing brackets UP02 up to UP04

		Pump sizes																																				
		Units		25-160	25-200	32-125	32-160	32-200	40-160	40-200	50-160	50-200	32-250	40-250	40-315	50-250	50-315	65-160	65-200	65-250	80-160	80-200	80-250	100-200	65-315	80-315	80-400	100-250	100-315	100-400	125-250	125-315	125-400	150-250				
Bearing bracket		UP02												UP03						UP04																		
General	corrosion allowance	mm	3												3						3																	
	Impeller outlet width	mm	6	6	8	7	7	9	7	15	12	6	7	8	10	8	20	16	13	27	22	17	29	10	14	11	23	19,5	15	32	26	20	46					
	impeller inlet diameter	mm	45	45	52	52	52	65	65	82	82	52	65	65	84	84	89	96	96	100	114	114	122	96	129	118	129	135	129	154	154	154	180					
	max. impeller diameter	mm	See individual curve																																			
	min. impeller diameter	mm	See individual curve																																			
Shaft diam.	in stuffing box housing	mm	28 / 33 ¹⁾												38 / 43 ¹⁾						48 / 53 ¹⁾																	
	at bearings	pump end	mm	35												55						55																
		motor end	mm	35												55						55																
	at coupling	mm	24												32						42																	
Shaft prot. sleeve	Packing	mm	35												45						55																	
	Mechanical seal (Standard)	mm	KU 33 / KB 33												KU 43 / KB 43						KU 53 / KB 53																	
Bearings	pump end	No.	NU 307												NU 311						NU 311																	
	motor end	No.	2 x 7307 BUA												2 x 7311 BUA						2 x 7311 BUA																	
Shaft deflection			At 0.05 mm at the shaft seal, max. shaft deflection is in compliance with ISO 5199																																			
Pressure limit	max. operating pressure	bar	See diagram, page 3																																			
	max. test pressure	bar	1.5 x max. permissible pump discharge pressure																																			
Temp.li.	max. product temperatur	°C	See diagram, page 3																																			
Drive	P/n-value		Depends on material and temperature - on request																																			

Pumps on bearing brackets UP05 up to P12s

		Pump sizes																																				
		Units		150-315	150-400	150-500	200-250	200-315	200-400	200-500	250-315	250-400	250-500	150-630	200-670	300-400	300-500	350-400	350-500	250-630	250-710	300-630	300-710	400-504	400-506	350-630	350-710	400-630	400-710									
Bearing bracket		UP05												UP06		P08s				P10as				P12s														
General	corrosion allowance	mm	3												3		3				3				3													
	Impeller outlet width	mm	38	29	23	62	50	40	32	73	63	43	21	25	68	58	115	72	40	38	46	46	81	106	58	53	76	68										
	impeller inlet diameter	mm	190	190	190	190	222	222	222	270	294	280	202	250	294	320	337	340	290	275	326	326	373	400	360	360	400	400										
	max. impeller diameter	mm	See individual curve																																			
	min. impeller diameter	mm	See individual curve																																			
Shaft diam.	in stuffing box housing	mm	60 / 65 ¹⁾												65 / 75 ¹⁾		80				100				120													
	at bearings	pump end	mm	65												80		80				120				120												
		motor end	mm	65												95		95				120				120												
	at coupling	mm	48												60		75				90				110													
Shaft prot. sleeve	Packing	mm	70												80		100				120				140													
	Mechanical seal (Standard)	mm	KU 65/KB 65												KU75/K B70		KU 95/KB 90				KU 110/KB 110				KU 130/KB 130													
Bearings	pump end	Nr.	NU 313												NU 416		NU 416				NU 324				NU 324													
	motor end	Nr.	2 x 7313 BUA												2x7319B UA		2 x 7319 BUA				2 x 7324 BUA				2 x 7324 BUA													
Shaft deflection			At 0.05 mm at the shaft seal, max. shaft deflection is in compliance with ISO 5199																																			
Pressure limit	max. operating pressure	bar	See diagram, page 3																																			
	max. test pressure	bar	1.5 x max. permissible pump discharge pressure																																			
Temp.li.	max. product temperatur	°C	See diagram, page 3																																			
Drive	P/n-value		Depends on material and temperature - on request																																			

1) Model with "wet shaft" (optional)

Pump Size / Bearing Bracket Combinations

Dis-charge nozzle DN	Nominal impeller diameter											Bearing bracket	
	125	160	200	250	315	400	500	504	506	630	670		710
25		x ¹⁾⁵⁾	x ¹⁾⁵⁾										UP 02
32	x	x ¹⁾	x ¹⁾	x ¹⁾									UP 03
40		x ¹⁾	x ¹⁾	x ¹⁾	x ¹⁾								
50		x ¹⁾	x ¹⁾	x ¹⁾	x ¹⁾								
65		x ¹⁾	x ¹⁾	x ¹⁾	x ¹⁾³⁾								UP 04
80		x ¹⁾	x ¹⁾²⁾	x ¹⁾²⁾	x ¹⁾²⁾	x ¹⁾³⁾							UP 05
100			x ¹⁾²⁾	x ¹⁾²⁾	x ¹⁾²⁾	x ¹⁾²⁾							UP 06
125				x ¹⁾	x ¹⁾	x ¹⁾²⁾							P 08s
150				x ¹⁾	x ¹⁾	x ¹⁾²⁾	x ¹⁾		x				
200				x ¹⁾	x ¹⁾⁴⁾	x ¹⁾	x ¹⁾			x			P10as
250					x ¹⁾	x ¹⁾⁶⁾	x ¹⁾⁶⁾			x		x	
300						x ¹⁾⁶⁾	x ¹⁾⁶⁾			x		x	
350						x ¹⁾⁶⁾	x ¹⁾⁶⁾			x		x	P 12s
400									x	x	x	x	

- Double volute casing
- 1) Casing cover with conical seal chamber possible
- 2) CPKN-C1 standard design without double volute
- 3) CPKN-E/S with double volute
- 4) CPKN-E with double volute
- 5) not as CPKN-S
- 6) Design with conical seal chamber not possible on CPKN-S

Casing

Radially split, consisting of volute casing (on CPKN-S with casing wear ring) and casing cover.

Double volute depending on pump size.

The casing cover and the bearing bracket lantern form a chamber which can be used for heating or cooling with superheated steam or water, respectively (except for pump design with conical seal chamber).

Balancing

Axial thrust is balanced by back vanes, for impeller diameters > 500 with sealing clearance on both sides.

Shaft Seal

The shaft seal can be designed as a gland packing or a mechanical seal.

Conversion from gland packing to single-acting mechanical seal and vice versa is possible without any rework on the casing cover by using the relevant replacement parts.

The pumps use proprietary single or double seals. Preference is given to standardised mechanical seals of various makes to EN 12756 (type of construction L₁K).

Single-acting mechanical seals can be fed with quenching media. A throttling bush, shaft seal ring or secondary mechanical seal can be fitted as outboard seal.

Gland Packing

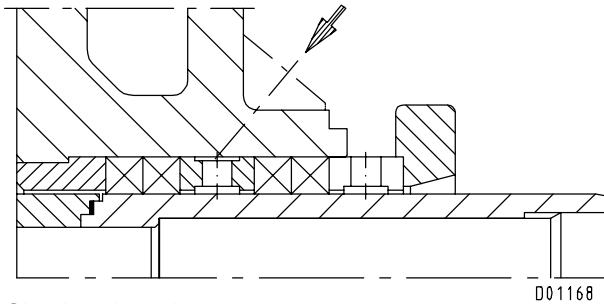

Gland packing design

Examples of Mechanical Seal Arrangements

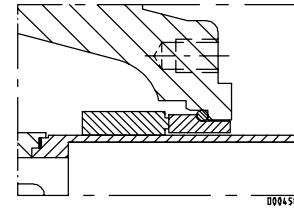

Conical seal chamber (A-type cover)

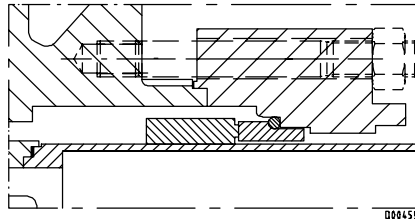

Cylindrical seal chamber

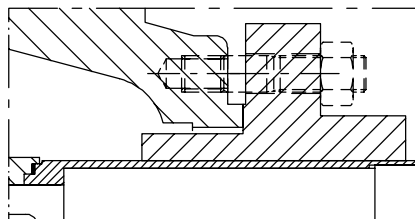

Cartridge seal

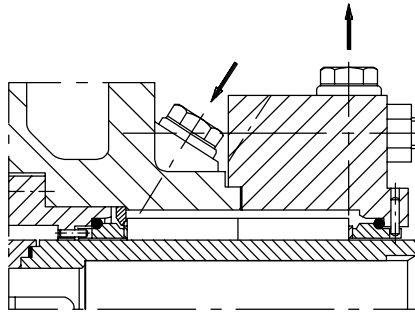

Shaft seal: double-acting mechanical seal (back to back), both sides unbalanced.

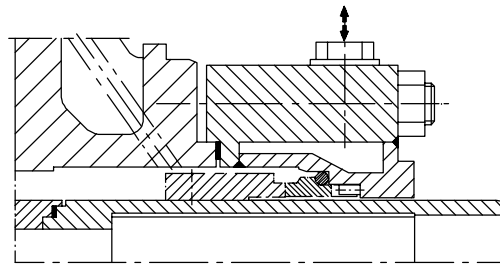

Shaft seal: single-acting mechanical seal; for CPKN-CH with heatable seal cover.

Mechanical Seals Installed in CPKN Pumps

(UP02 - UP06)

Design	Make	Type unbalanced	Type balanced
Single-acting	KSB choice	A ³⁾	H75N
	Burgmann	M7N ³⁾ MG1 - G6 ¹⁾	
Cartridge single-acting	Flowserve	MFL85N	
	Crane	600 ³⁾	610
		59U ³⁾	59B
		502 ³⁾	
		209 V seat ⁴⁾ 10T ⁵⁾	
Cartridge single-acting	Burgmann	Cartex-SN	
	Crane	Cartex-QN 5610 5615	
Double-acting b.t.b.	KSB's choice	A... / A... ²⁾	
	Burgmann	M7N / M7N ²⁾	
	Pacific	600 / 600 ²⁾	
	Crane	59U / 59U ²⁾	
Cartridge double-acting	Burgmann	Cartex-DN	
	Crane	5620 5625	

- 1) For pump design with conical seal chamber only
- 2) Pumping ring possible
- 3) Also possible in conical seal chamber
- 4) For CPKN-CH only
- 5) Acid - mechanical seal - on request

Acceptance Tests / Guarantees

- **Materials tests**
Test report 2.2 on request
- **Product tests**
Inspection certificate 3.1, on request, for:
pressure test of complete pump as per EN 10204
- **Hydraulic tests**

Each pump is subjected to a performance test run, and its duty point is guaranteed according to ISO 9906/2A.

The following acceptance tests can be performed and certified at extra charge:

- Performance test ISO 9906/2A 5 measuring points
- Performance test ISO 9906/1 5 measuring points
(see individual curve)
- NPSH test 1 measuring point

Warranties are given within the scope of the valid delivery conditions.

Recommended Spare Parts Stock for Two Years' Operation to DIN 24296

Part No.	Description	Number of pumps (incl. standby pumps)						
		2	3	4	5	6+7	8+9	10 and more
		Quantity of spare parts						
210	Shaft	1	1	1	2	2	2	20 %
230	Impeller	1	1	1	2	2	2	20 %
320.02	Angular contact ball bearing (set)	1	1	2	2	2	3	25 %
322.01	Cylindrical roller bearing	1	1	2	2	2	3	25 %
433	Mechanical seal, complete	1	1	2	2	2	3	25 %
456.01	Neck bush	1	1	2	2	2	3	30 %
461.01	Gland packing (set)	4	4	6	6	6	8	100 %
502.01	Casing wear ring	2	2	2	3	3	4	50 %
524.01	Shaft protecting sleeve	2	2	2	3	3	4	50 %
--	Gaskets for pump casing (set)	4	6	8	8	9	12	150 %
--	Torque transmission elements (coupling, set)	1	1	2	2	3	4	30 %

Coating and Preservation

(acc. to works standard AN 1865)

CPKN-S, -E	< 150 °C	N	1	1	1	W
	≥ 150 °C	N	7	7	7	W
CPKN-C	< 150 °C	N	0	1	1	U
	≥ 150 °C	N	0	7	7	U

Key:

Treatment of unmachined parts

Coating - pressure-retaining parts

Coating - bearing bracket, baseplate

Coating - motor

Preservation

N = reaction primer, parts in contact with the fluid handled without last paint coat

0 = without top coat

1 = synthetic enamel RAL 5002, ultramarine blue

7 = heat-resistant enamel RAL 9007, aluminium-grey

U = untreated

W = rinsed with water repellent agent; blank parts liable to rust with protective coating

Forces and Moments

CPK pumps are designed for handling forces and moments in accordance with ISO 5199.

Documentation

Printed documentation adapted to CE requirements

- general assembly drawing with list of components
- sectional drawing
- installation plan / dimensions table
- operating instructions

Dimensions and Connections

CPKN

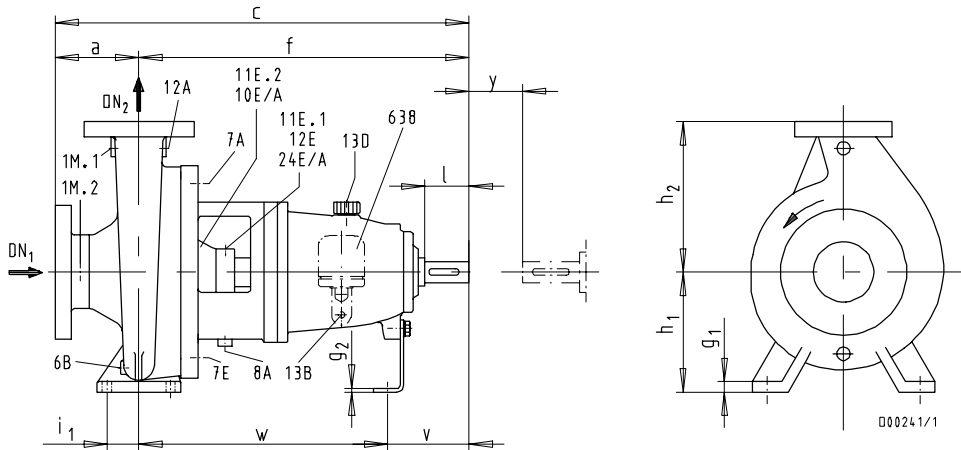

y = clearance for dismantling without removing the motor

CPKN-CH

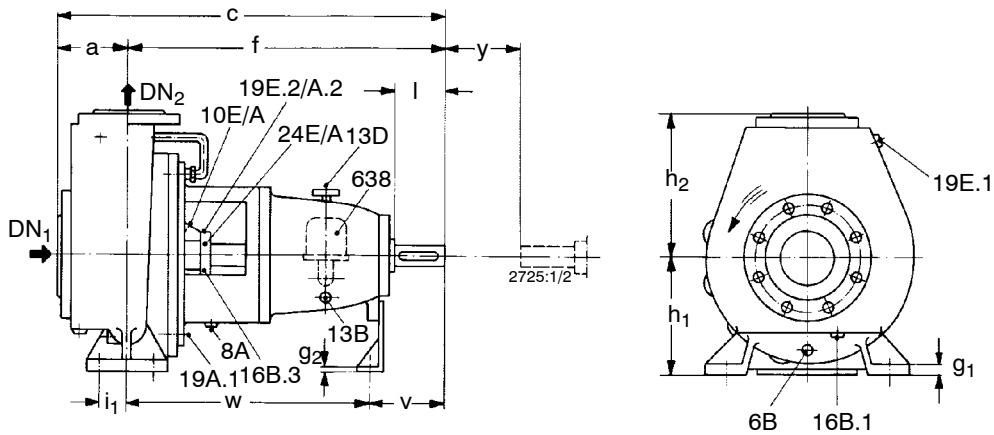

y = clearance for dismantling without removing the motor

CPKN / CPKN-CH

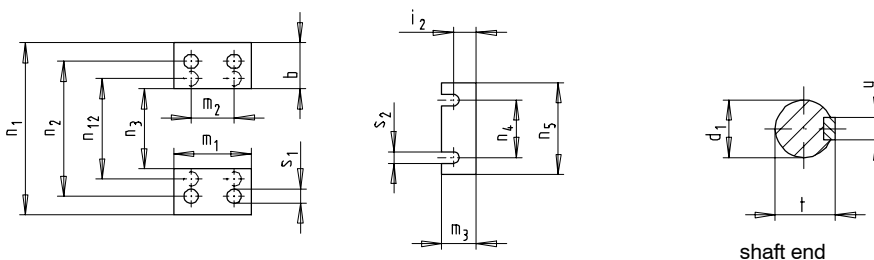
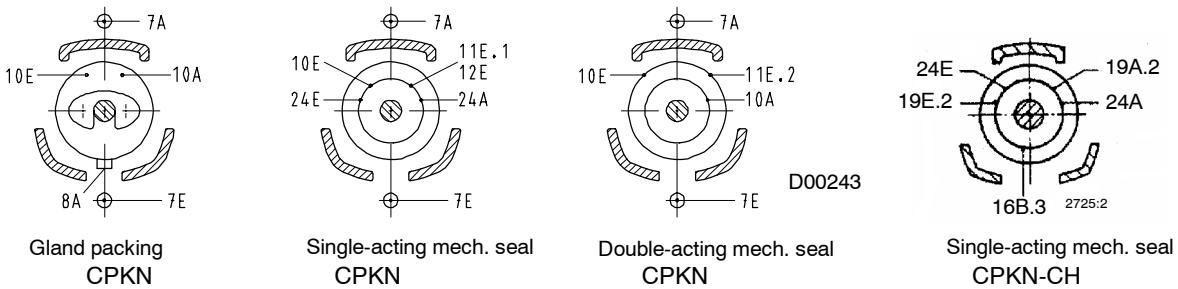

shaft end
key in acc. with DIN 6885/Sh 1

Flange design

CPKN-S1	EN 1092-2, PN 16 ¹⁾
CPKN-C1/C1V/CHs	EN 1092-1, PN 16
CPKN-C3.2	EN 1092-1, PN 25
CPKN-C3.1	EN 1092-1, PN 16
CPKN-S2	EN 1092-2, PN 25
CPKN-E	EN 1092-1, PN 25

1) drilled

General Assembly Drawing with List of Components

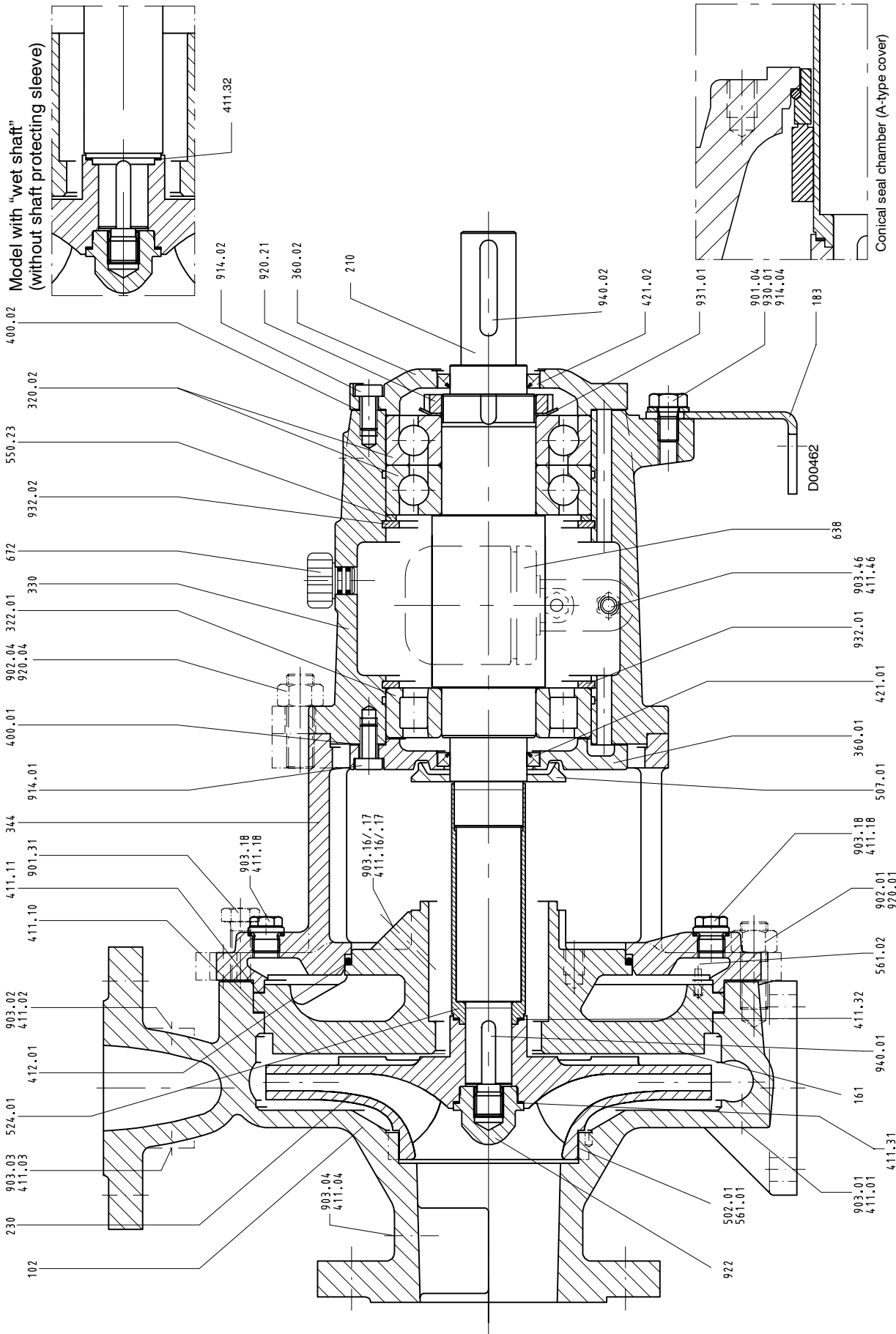

When ordering spare parts, please always specify:

Type series/pump size, works No. (stamped on the name plate and on the suction nozzle flange), motor No. (serial No.), year of construction, quantity required, part No., description, material, fluid handled, general assembly drawing No. and mode of dispatch.

Part No.	Description	Scope of supply
102	Volute casing	with joint ring 411.01/.02/.03/.04, casing wear ring 502.01 ¹⁾ , stud 902.01, screwed plug 903.01/.02/.03/.04, hex. nut 920.01, joint ring 411.10 depending on the application temperature - order separately in spare parts order
161	Casing cover	with joint ring 411.11/.16/.17, O-ring 412.01 ²⁾ , stud 902.02 ⁴⁾ , screwed plug 903.16/.17, hex. nut 920.02
183	Support foot	with hex. head bolt 901.04 ³⁾ , spring washer 930.01
210	Shaft	with keywayed nut 920.21, lockwasher 931.01, key 940.01/.02
230	Impeller	with joint ring 411.32
320.02	Angular contact ball bearing	
322.01	Cylindrical roller bearing	
330	Bearing bracket	
330	Bearing bracket (complete)	with bearing cover 360.01/.02, gasket 400.01/.02, joint ring 411.46, lip seal 421.01/.02, support disc 550.23, constant-level oiler 638, vent plug 672, screwed plug 903.46, hex. socket head cap screw 914.01/.02, circlip 932.01/.02
344	Bearing bracket lantern	with O-ring 412.01 ²⁾ , parallel pin 561.02, screwed plug 903.18, stud 902.04, hex. head bolt 901.31, hex. nut 920.04, joint ring 411.18
360.01/.02	Bearing cover	with gasket 400.01/.02, hex. socket head cap screw 914.01/.02
421.01.02	Lip seal	
433.01	Mechanical seal (compl.) ⁴⁾	
471.01	Seal cover ⁴⁾	with joint ring 411.15, grooved pin 561.03
502.01 ¹⁾	Casing wear ring	with parallel pin 561.01
507.01	Thrower	
524.01	Shaft protecting sleeve	with joint ring 411.32
638	Constant-level oiler	
922	Impeller nut	with joint ring 411.31

1) on CPKN - S only

2) not fitted on pump version with conical seal chamber

3) on bearing bracket LP02: socket head cap screw 914.04

4) not shown in drawing

Impeller diameter 504 and above

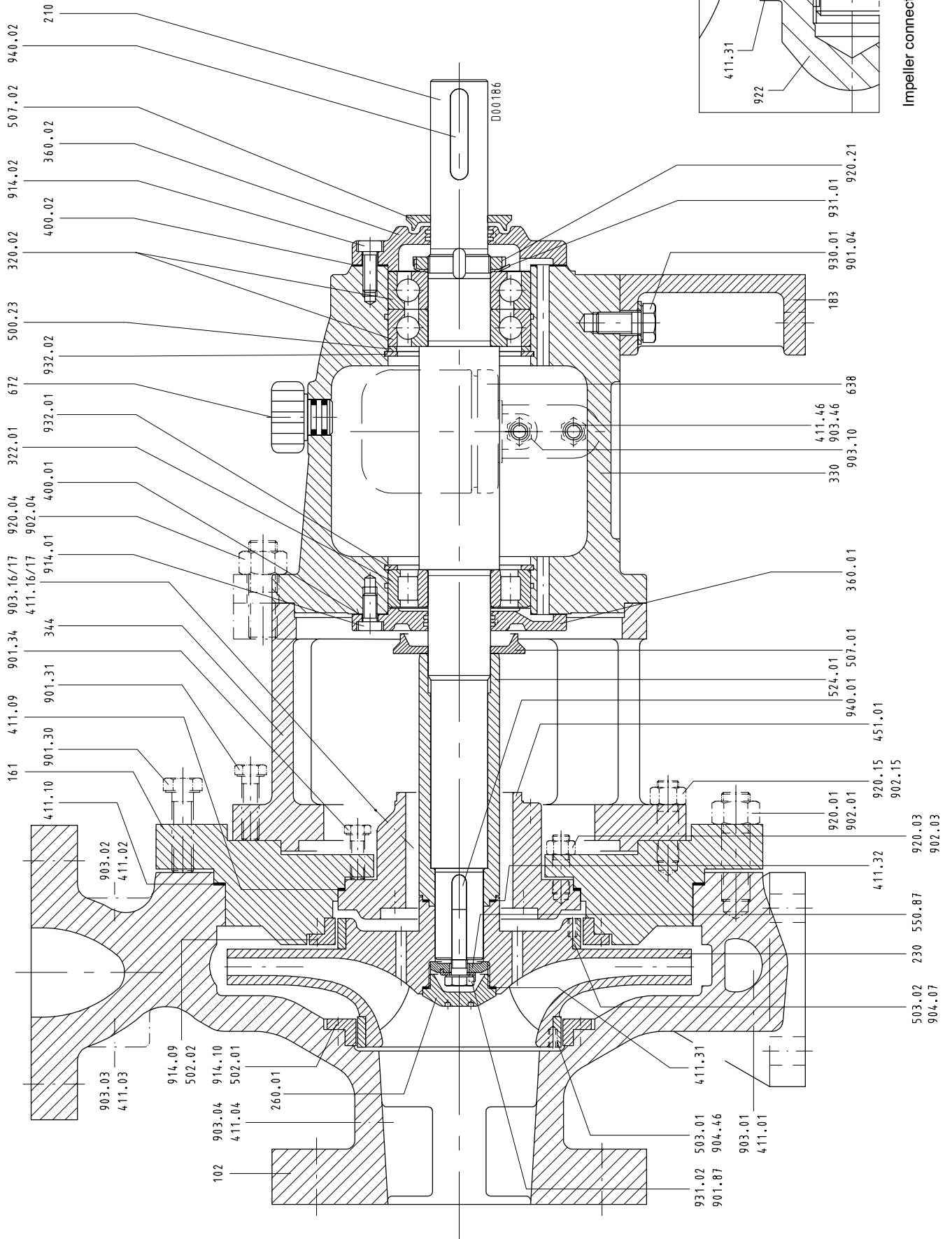

When ordering spare parts please always specify the type series/pump size, works No. (stamped on the name plate and on the suction nozzle flange), motor No. (serial No.), year of construction, quantity required, part No., description, material, fluid handled, sectional drawing No. and mode of dispatch.

Part No.	Description	Scope of supply
102	Volute casing	with joint ring 411.01/.10, casing wear ring 502.01, stud 902.01, screwed plug 903.01, socket head cap screw 914.10, hex. nut 920.01, joint ring 411.10 depending on the application temperature - order separately in spare parts order
161	Casing cover	with joint ring 411.09, casing wear ring 502.02, stud 902.15, socket head cap screw 914.09, hex. nut 920.15
183	Support foot	
210	Shaft	with keywayed nut 920.21, lockwasher 931.01, key 940.01/.02
230	Impeller	with impeller wear ring 503.01/.02 (if fitted)
260.01	Impeller cap	(bearing brackets P 10as, P 12s)
320.02	Angular contact ball bearing	
322.01	Cylindrical roller bearing	
330	Bearing bracket	
344	Bearing bracket lantern	with stud 902.04, hex. nut 920.04
360.01/.02	Bearing cover	
451.01	Stuffing box housing	with stud 902.03, screwed plug 903.16/.17, hex. nut 920.03
502.01/.02	Casing wear ring	
507.01/.02	Thrower	
524.01	Shaft protecting sleeve	
550.23	Support disc	(bearing brackets P 10as, P 12s)
550.87	Disc	
638	Constant-level oiler	
672	Vent plug	
901.04	Hex. head bolt	
901.87	Hex. head bolt	(bearing brackets P 10as, P 12s)
903.46	Screwed plug	
914.01/.02	Socket head cap screw	
914.09/.10	Socket head cap screw	
922	Impeller nut	(bearing bracket P 08s)
930.01	Spring washer	
931.01	Lockwasher	
931.02	Lockwasher	(bearing brackets P 10as, P 12s)
932.01/.02	Circlip	

CPKN-CH

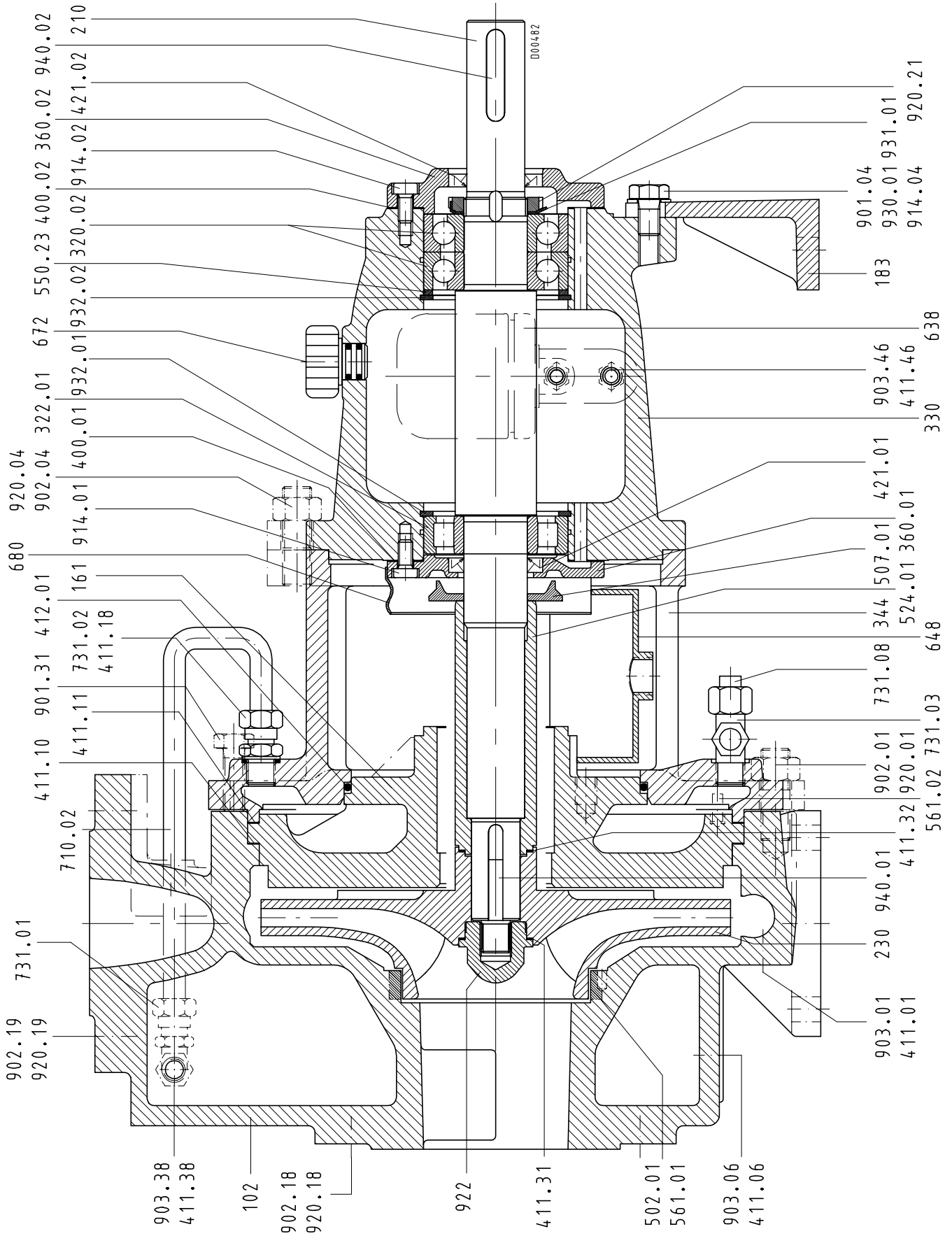

When ordering spare parts please always specify:
the type series, pump size, works No. (stamped on the name plate and on the
suction nozzle flange), motor No. (serial No.), year of manufacture, quantity required,
part No., part designation, material, fluid handled, sectional drawing No. and mode of dispatch.

Part No.	Designation	Scope of supply
102	Volute casing	with joint ring 411.01/06/10/18/38, casing wear ring 502.01, grooved pin 561.01, pipe union 731.01, stud 902.01/18/19, screwed plug 903.01/06/38, hex. nut 920.01/18/19
161	Casing cover	with joint ring 411.11/16 ¹⁾ /17 ¹⁾ , O-ring 412.01, disc 550.01 ¹⁾²⁾ , grooved pin 561.02, pipe union 731.03/08, stud 902.02 ¹⁾ , hex. nut 920.02 ¹⁾
183	Support foot	with hex. head bolt 901.04 ²⁾ , spring washer 930.01
210	Shaft	with keywayed nut 920.21, lockwasher 931.01, key 940.01/02
230	Impeller	with joint ring 411.32
320.02	Angular contact ball bearing	
322.01	Cylindrical roller bearing	
330	Bearing bracket	
330	Bearing bracket complete	with gasket 400.01/02, joint ring 411.46, vent plug 672, screwed plug 903.46, bearing cover 360.01/02, lip seal 421.01/02, support disc 550.23, constantlevel oiler 638, socket head cap screw 914.01/02, circlip 932.01/02
344	Bearing bracket lantern	with pipe union 731.01/02, stud 902.04, hex. head bolt 901.31, hex. nut 920.04
360.01/02	Bearing cover	with gasket 400.01/02, radial shaft seal ring 421.01/02, socket head cap screw 914.01/02
421.01/02	Radial shaft seal ring	
502.01	Casing wear ring	
507.01	Thrower	with joint ring 411.32
524.01	Shaft protecting sleeve	
638	Constant-level oiler	
648	Drip pan	
680	Guard	
710.02	By-pass pipe	with pipe union 713.01/02, joint ring 411.18/32
922	Impeller nut	with joint ring 411.31

1) not illustrated

2) on bearing bracket P 02a/as hexagon socket head cap screw 914.04

