

The Calpeda 4", 6", 8" and 10" submersible motors are built using advanced technology and components of superior quality that they ensure good mechanical strength and excellent electrical reliability. The good performances are guaranteed thanks to strict tests of all the different components during the various production phases.

### Rewindable motor CS-R series

The **CS-R** 6/8/10" motors are in a water bath with the wire being coated with polyvinyl chloride, while the **CS-R** 4" motors have a special food grade dielectric fluid that gives a better lubricant effect, increasing the life of all moving parts and the copper wires. The special design of all our motors allows easy access to the various components, simplifying maintenance and repair.

**CS, CS-R:** Standard construction.  
**I-CS, I-CS-R:** AISI 316 construction.

### Operation data

2-pole induction motor, 50 Hz (n ≈ 2900 rpm).  
 Sized for connection to the pumps according to NEMA Standards (10" excluded).  
 Standard voltages:  
 - single-phase 230 V - up to 2,2 kW for 4" motors.  
 - three-phase 230 V; (5,5 kW excluded) 400 V for 4" motors.  
 - three-phase 400 V; 400/690 V for 6-8-10" motors.  
 Voltage tolerance : ± 10% (+6%/-10% for 4").

In order to limit both current and torque at each starting, for rated motor powers equal to or higher than 7.5kW, one of the following types of starting is necessary: star/delta, soft starter, stator impedance or autotransformer.

Insulation class:  
 - class F for 4" motors,  
 - class E for 6" motors, PVC for I-6" (I-6" 45 kW PE2+PA).  
 - PVC for 8"  
 - PVC for 10" (10" 170kW and 190 kW PE2+PA)

Protection IP 68.  
 Installation below water level: 100 m for 4", 150 m for 6", 500 m for 8,10"  
 Motor suitable operation with frequency converter (with suitable filter dv/dt for 6.8.10") (4" single-phase excluded).  
 Horizontal installation (6" 37-45kW, 8" 92kW, 10" 170-190 kW excluded)

### Operating conditions

Motor	P2	Max. Liquid temperature	Cooling minimum flow velocity	Max. starts per hou
4CS-R	all types	35 °C	0,08 m/s	20
6CS-R	4÷11 kW	30 °C	0,1 m/s	15
	13÷15 kW	30 °C	0,2 m/s	15
	18,5 kW	25 °C	0,2 m/s	15
	22÷30 kW	25 °C	0,2 m/s	13
	37 kW	40 °C	0,1 m/s	13
I-6CS-R	45 kW	40 °C	0,3 m/s	6
	4÷37 kW	30 °C	0,15 m/s	20
8CS-R	45 kW	45 °C	0,15 m/s	20
	all types	30 °C	0,15 m/s	10
10CS-R	75÷150 kW	30 °C	0,15 m/s	10
	170÷190 kW	50 °C	0,15 m/s	10

Continuous duty.

### Special features on request

- Other voltage.
- Frequency 60 Hz.
- Higher liquid temperature.
- Bronze, AISI 904 and Super Duplex version for 6.8.10".
- PT100 temperature sensor
- PE2 / PA winding insulation
- Cooling jackets



kW	4" 1~		4" 3~		6" 3~		8" 3~		10" 3~	
	CS-R	CS-R	CS-R	I-CS-R 316	CS-R	I-CS-R 316	CS-R	I-CS-R 316	CS-R	I-CS-R 316
0,37	•	•								
0,55	•	•								
0,75	•	•								
1,1	•	•								
1,5	•	•								
2,2	•	•								
3		•								
4		•	•	•						
5,5		•	•	•						
7,5			•	•						
9,2			•	•						
11			•	•						
13			•	•						
15			•	•						
18,5			•	•						
22			•	•						
26			•	•						
30			•	•	•	•				
37			•	•	•	•				
45			•	•	•	•				
51					•	•				
59					•	•				
66					•	•				
75					•	•	•	•		
92						•	•		•	•
110									•	•
132									•	•
150									•	•
170									•	•
190									•	•

### Materials

Components	4"	
External frame	Cr-Ni steel AISI 304	
Motor flange	Cast iron GJL 200 EN 1561 nickel-plated	
Shaft end	Cr-Ni-Mo steel AISI 316	
Thrust bearing	Oil wetted	
Components	6", 8", 10" standard	6", 8", 10" AISI 316
External frame	Cr-Ni steel AISI 304	Cr-Ni-Mo steel AISI 316
Motor flange	Cast iron GJL 200 EN 1561 (Cast iron G 25 EN 1561 for 8,10")	Cr-Ni-Mo steel AISI 316
Shaft end	Cr-Ni steel AISI 431 (Steel AISI 420 for 8")	Duplex 1.4462
Thrust bearing	Oscillating pads	Oscillating pads
Bushings	Resin/ Graphite compound (Graphite for 6")	Resin/ Graphite compound

### Cable

Motor 230V - 50Hz - 1~	Section	Length
4CS-R 0,37 ÷ 2,2 kW	3x2 + 1G2 mm <sup>2</sup>	2 m
Motor 400V - 50Hz - 3 ~	Section	Length
4CS-R 0,37 ÷ 1,5 kW	3x2 + 1G2 mm <sup>2</sup>	2 m
4CS-R 2,2 ÷ 5,5 kW	3x2 + 1G2 mm <sup>2</sup>	3 m
6CS-R 4 ÷ 11 kW	3 x (1x2,5) mm <sup>2</sup>	3,5 m
6CS-R 13 ÷ 22 kW	3 x (1x4) mm <sup>2</sup>	3,5 m
6CS-R 26 - 30 kW	3 x (1x6) mm <sup>2</sup>	3,5 m
6CS-R 37 - 45 kW	3 x (1x10) mm <sup>2</sup>	3,5 m
I-6CS-R 4 ÷ 15 kW	3 x (1x4) mm <sup>2</sup>	3,5 m
I-6CS-R 18,5 ÷ 26 kW	3 x (1x6) mm <sup>2</sup>	3,5 m
I-6CS-R 30 kW	3 x (1x10) mm <sup>2</sup>	3,5 m
I-6CS-R 37 ÷ 45 kW	3 x (1x10) mm <sup>2</sup>	4,5 m
8CS-R 30 kW	3 x (1x10) mm <sup>2</sup>	3,5 m
8CS-R 37 ÷ 59 kW	3 x (1x16) mm <sup>2</sup>	3,5 m
8CS-R 66 ÷ 75 kW	3 x (1x25) mm <sup>2</sup>	3,5 m
8CS-R 92 kW	3 x (1x25) mm <sup>2</sup>	4,5 m
10CS 75 ÷ 92 kW	3x(1x25) mm <sup>2</sup>	4,5 m
10CS 110 kW	3x(1x35) mm <sup>2</sup>	4,5 m
10CS 132 kW	3x(1x50) mm <sup>2</sup>	4,5 m
10CS 150 ÷ 170 kW	3x(1x70) mm <sup>2</sup>	4,5 m
10CS 190 kW	3x(1x95) mm <sup>2</sup>	4,5 m

### Cooling jacket

When the submersible motor is installed :

- below the well inlet points (**picture A**);
- in tanks, lakes, basins, etc... (**pictures B and C**)

an external jacket must be installed to create a cooling flow around the motor. Only in this way a safe operation can be assured avoiding any overheating which can damage the motor.

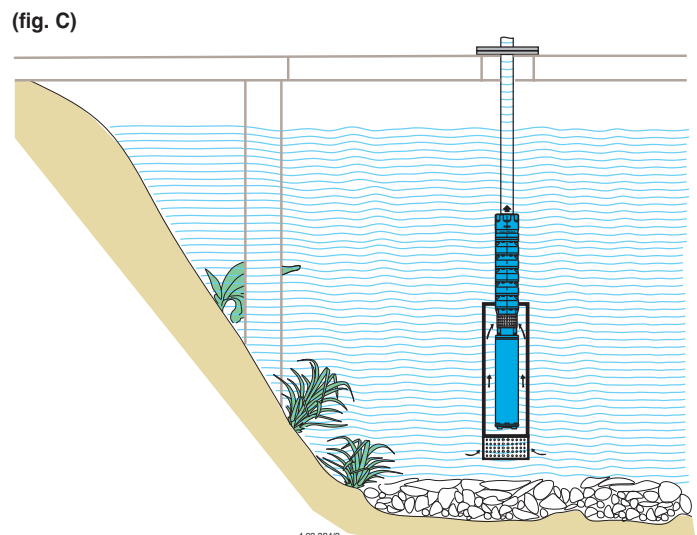
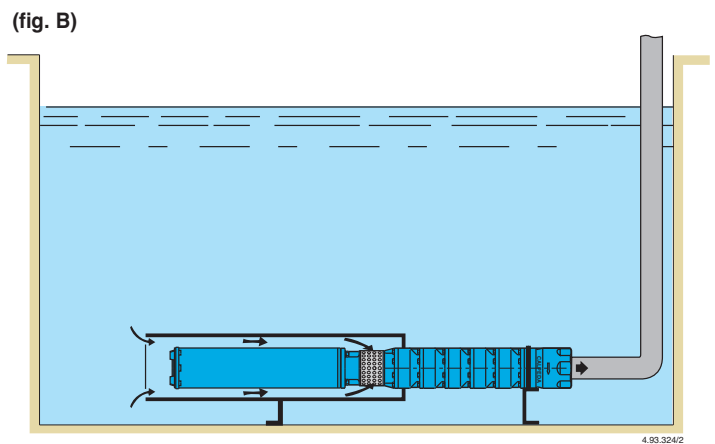
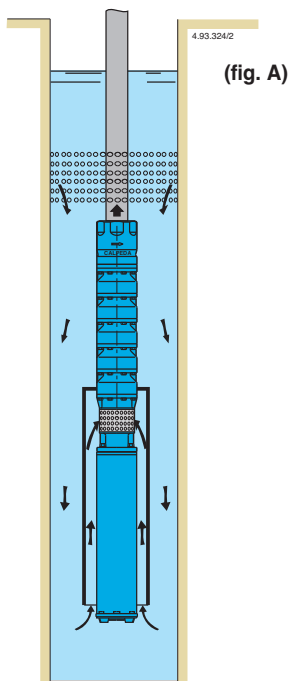

### Performance, dimensions and weights

#### 4"CS-R - 1 ~

Type	PN		IN 230 V A	Power factor cos φ			Efficiency η %			R.P.M.	Direct start		Capacitor 450 Vc μF	Axial thrust N	M mm	Weight kg
	kW	HP		4/4	3/4	2/4	4/4	3/4	2/4		I <sub>A</sub> IN	C <sub>A</sub> CN				
4CS-R 0,37M	0,37	0,5	3.2	0.96	0.93	0.85	53	46	29	≈ 2850	3.8	0.78	16	1500	327	7,6
4CS-R 0,55M	0,55	0,75	4.0	0.99	0.97	0.89	62	54	35		4.6	0.80	25		362	9,4
4CS-R 0,75M	0,75	1	5.6	0.96	0.91	0.80	61	55	36		3.6	0.66	30		362	9,4
4CS-R 1,1M	1,1	1,5	8.0	0.93	0.86	0.71	66	59	38		4.2	0.65	40		402	10,7
4CS-R 1,5M	1,5	2	10.8	0.94	0.89	0.75	64	59	39		3.5	0.75	60		447	12,4
4CS-R 2,2M	2,2	3	14.7	0.96	0.93	0.80	67	64	44		4.2	0.51	70		517	15,7

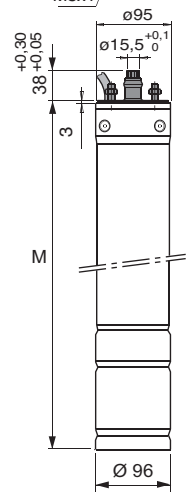
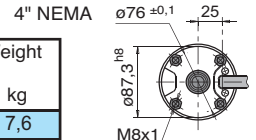

#### 4"CS-R - 3 ~

Type	PN		IN 400 V A	Power factor cos φ			Efficiency η %			R.P.M.	Direct start		Axial thrust N	M mm	Weight kg
	kW	HP		4/4	3/4	2/4	4/4	3/4	2/4		I <sub>A</sub> IN	C <sub>A</sub> CN			
4CS-R 0,37T	0,37	0,5	1.2	0.73	0.64	0.47	63	58	44	≈ 2850	5.6	4.2	1500	327	7,7
4CS-R 0,55T	0,55	0,75	1.5	0.80	0.71	0.53	68	66	52		6.1	4.1		327	7,7
4CS-R 0,75T	0,75	1	2.2	0.77	0.69	0.50	65	63	49		4.2	3		347	8,7
4CS-R 1,1T	1,1	1,5	2.8	0.80	0.71	0.49	72	73	62		4.5	3		362	9,5
4CS-R 1,5T	1,5	2	3.7	0.79	0.70	0.47	76	75	65		5.0	3.1		402	10,8
4CS-R 2,2T	2,2	3	5.5	0.81	0.71	0.47	72	73	62		4.9	2.2		402	11,7
4CS-R 3T	3	4	7.4	0.81	0.72	0.56	73,5	73,5	69		5,7	2,16	481	14,9	
4CS-R 4T	4	5,5	9,4	0,82	0,74	0,60	74,5	75	71		6,3	2,19	546	18,2	
4CS-R 5,5T	5,5	7,5	13	0,81	0,72	0,57	76	76	71		7,8	3,44	646	23	

#### 6"CS-R

Type Standard	PN		IN 400 V A	Power factor cos φ		Efficiency η %		R.P.M.	Direct start		Axial thrust N	M mm	Weight kg
	kW	HP		4/4	3/4	4/4	3/4		I <sub>A</sub> IN	C <sub>A</sub> CN			
6CS-R 4	4	5,5	11	0,80	0,70	70	68	2825	3	1,5	30000	530	30,5
6CS-R 5,5	5,5	7,5	14,5	0,81	0,72	72	72	2815	3,2	1,5	30000	550	33
6CS-R 7,5	7,5	10	18,5	0,80	0,72	76	76	2830	4,1	2	30000	595	38
6CS-R 9,2	9,2	12,5	22	0,80	0,71	78	78	2840	4	1,7	30000	640	41,7
6CS-R 11	11	15	26	0,83	0,76	78	79	2835	5,2	2,5	30000	670	44,4
6CS-R 13	13	17,5	31	0,80	0,69	79	78	2840	5	2,6	30000	700	47,7
6CS-R 15	15	20	35	0,80	0,72	81	81	2855	5	1,95	30000	715	52
6CS-R 18,5	18,5	25	42	0,82	0,74	81	82	2840	5,4	2,5	30000	750	56
6CS-R 22	22	30	49,5	0,83	0,76	81	83	2820	4,5	1,7	30000	790	59,8
6CS-R 26	26	35	57,5	0,82	0,74	83	84	2850	5,3	2	30000	875	70
6CS-R 30	30	40	64,6	0,80	0,74	85	87	2845	5,3	2	30000	1025	85,7
6CS-R 37	37	50	82,5	0,80	0,72	86	87	2870	6	2,4	30000	1227	111
6CS-R 45	45	60	98,9	0,80	0,73	85	85	2860	5,1	2	30000	1287	119

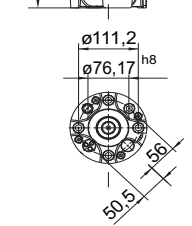
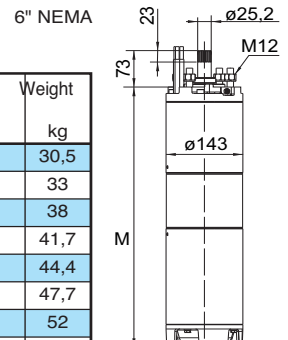

### Performance, dimensions and weights

#### I-6"CS-R

Type AISI 316	PN		IN 400 V A	Power factor cos φ			Efficiency η %			R.P.M.	Direct start		Axial thrust N	M mm	Weight kg
	kW	HP		4/4	3/4	2/4	4/4	3/4	2/4		I <sub>A</sub> IN	C <sub>A</sub> CN			
I-6CS-R 4	4	5,5	9,9	0,80	0,73	0,64	74,8	74,4	67,4	2852	6,8	1,2	25000	597	44
I-6CS-R 5,5	5,5	7,5	13	0,80	0,75	0,67	76,7	75,2	65,2	2839	7,2	1,2	25000	627	47
I-6CS-R 7,5	7,5	10	17	0,81	0,76	0,68	78,4	76,9	73,1	2837	7	1,3	25000	667	51
I-6CS-R 9,2	9,2	12,5	20	0,82	0,77	0,68	79,1	79,4	74,3	2862	7,2	1,2	25000	697	54
I-6CS-R 11	11	15	24	0,84	0,80	0,72	80,8	81,9	78,6	2841	6,9	1,2	25000	767	61
I-6CS-R 13	13	17,5	30	0,82	0,77	0,67	80	79,3	76,7	2863	7,2	1,2	25000	767	62
I-6CS-R 15	15	20	33	0,83	0,77	0,68	81,6	82,8	81,0	2836	7,3	1,4	25000	827	69
I-6CS-R 18,5	18,5	25	40	0,83	0,78	0,69	81,9	82,6	80,3	2853	7,4	1,3	35000	897	74
I-6CS-R 22	22	30	47	0,82	0,75	0,64	83,5	84	82,1	2868	8,4	1,5	35000	967	81
I-6CS-R 26	26	35	54	0,82	0,77	0,66	84,5	86,1	85,2	2864	6,9	1	35000	1027	90
I-6CS-R 30	30	40	62	0,82	0,77	0,66	85	85,7	84,9	2860	8,5	1,6	45000	1167	103
I-6CS-R 37	37	50	79	0,81	0,75	0,63	83,5	84,6	84,1	2856	8,6	2	45000	1297	117
I-6CS-R 45	45	60	98	0,83	0,76	0,63	80,5	83,4	83,8	2827	9,9	2,9	45000	1327	119

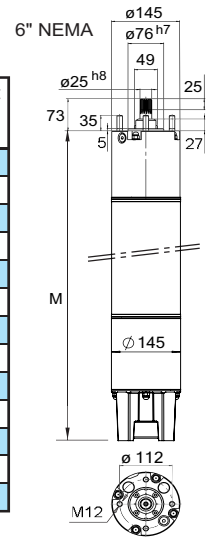

#### 8"CS-R, I-8"CS-R

Type		PN		IN 400 V A	Power factor cos φ			Efficiency η %			R.P.M.	Direct start		Axial thrust N	M mm	Weight kg
Standard	AISI 316	kW	HP		4/4	3/4	2/4	4/4	3/4	2/4		I <sub>A</sub> IN	C <sub>A</sub> CN			
8CS-R 30	I-8CS-R 30	30	40	61	0,85	0,82	0,75	83,9	84,9	82,3	2886	6,3	1	50000	1049	137
8CS-R 37	I-8CS-R 37	37	50	76	0,84	0,8	0,71	84,8	84,7	82,7	2890	6,9	1,2	50000	1119	157
8CS-R 45	I-8CS-R 45	45	60	91	0,84	0,79	0,71	86	86	83,4	2900	7,1	1,1	50000	1229	169
8CS-R 51	I-8CS-R 51	51	70	103	0,85	0,81	0,73	84,9	86,5	85,1	2879	8,1	1,9	60000	1229	170
8CS-R 59	I-8CS-R 59	59	80	116	0,83	0,79	0,69	87,5	88,6	87,4	2898	7,7	1,4	60000	1349	194
8CS-R 66	I-8CS-R 66	66	90	129	0,84	0,81	0,72	87,1	88	87	2883	7,4	2,4	70000	1419	210
8CS-R 75	I-8CS-R 75	75	100	146	0,85	0,81	0,73	86,9	87,7	86,5	2890	7,9	1,5	70000	1609	241
8CS-R 92	I-8CS-R 92	92	125	181	0,83	0,77	0,66	88,5	88,4	87,9	2900	8,6	1,8	70000	1679	251

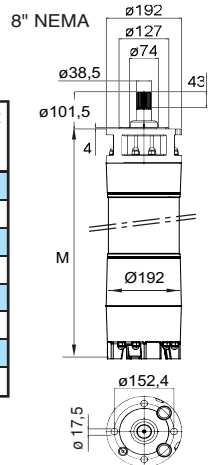

#### 10"CS-R, I-10"CS-R

Type		PN		IN 400 V A	Power factor cos φ			Efficiency η %			R.P.M.	Direct start		Axial thrust N	M mm	Weight kg
Standard	AISI 316	kW	HP		4/4	3/4	2/4	4/4	3/4	2/4		I <sub>A</sub> IN	C <sub>A</sub> CN			
10CS-R 75	I-10CS-R 75	75	100	154	0,83	0,81	0,75	84,8	83,7	81,3	2900	5,2	0,6	80000	1439	316
10CS-R 92	I-10CS-R 92	92	125	184	0,84	0,82	0,78	85,7	84	82	2891	5,2	0,6	80000	1569	349
10CS-R 110	I-10CS-R 110	110	150	217	0,84	0,82	0,76	87,1	87,6	86,5	2907	5,7	0,7	80000	1709	358
10CS-R 132	I-10CS-R 132	132	180	262	0,85	0,83	0,78	87	87,3	85,6	2892	5,6	0,7	80000	1809	417
10CS-R 150	I-10CS-R 150	150	200	294	0,83	0,8	0,73	88,1	88,7	87,1	2907	5,9	0,6	80000	1929	460
10CS-R 170	I-10CS-R 170	170	230	334	0,83	0,79	0,71	87,5	88,4	87,2	2900	6,6	1	80000	2029	484
10CS-R 190	I-10CS-R 190	190	260	374	0,83	0,79	0,7	88,3	89,5	89,2	2904	5,9	0,7	80000	2129	520

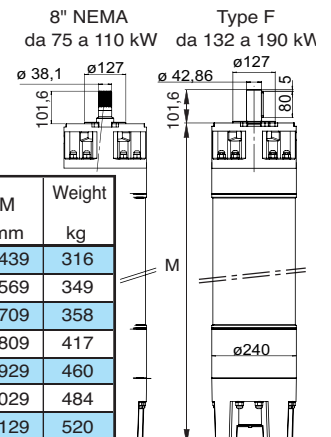

PN Rated power output IN Rated current

$\frac{I_A}{IN}$  Starting current / Nominal current

$\frac{C_A}{CN}$  Starting torque/Nominal torque

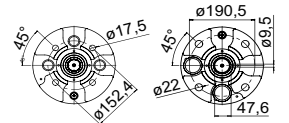

### Relationship between temperature and salinity

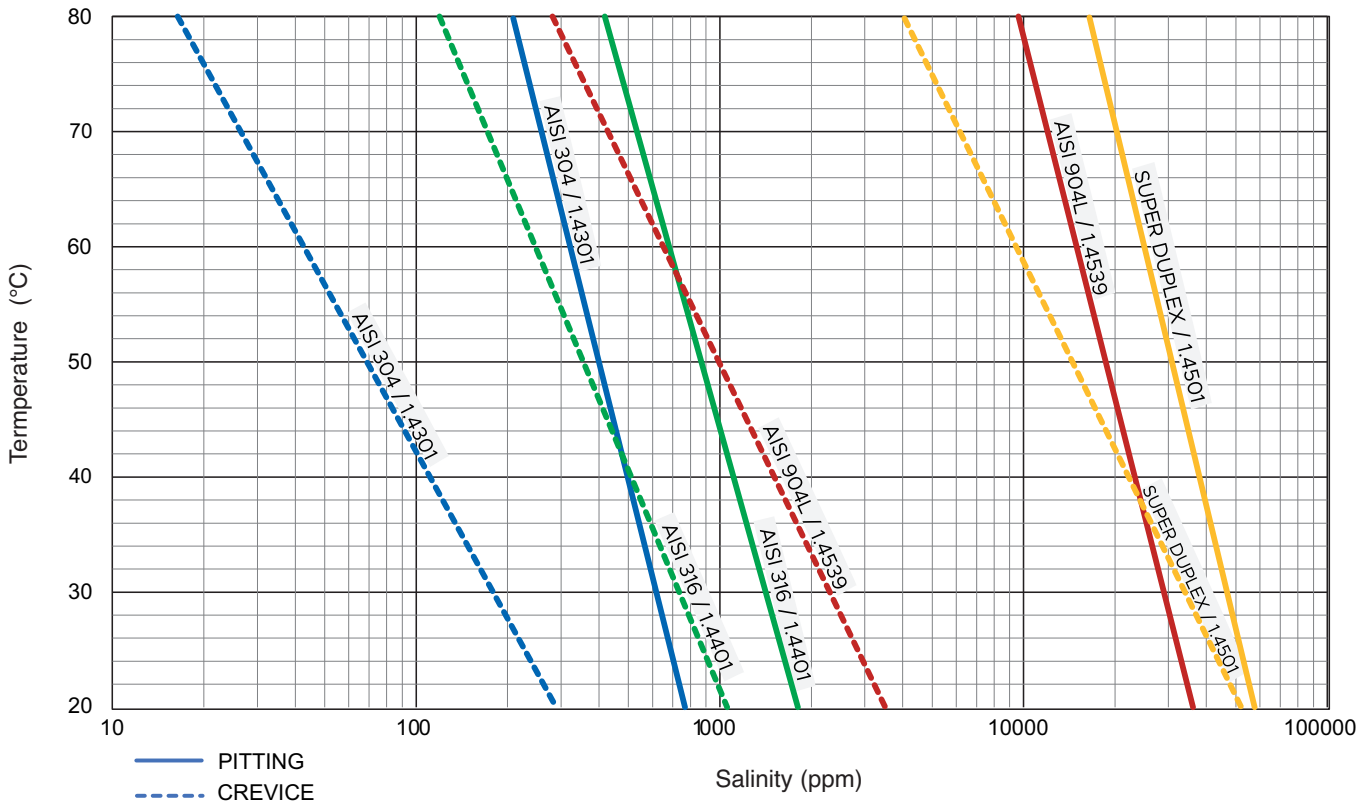

### Coupling flange

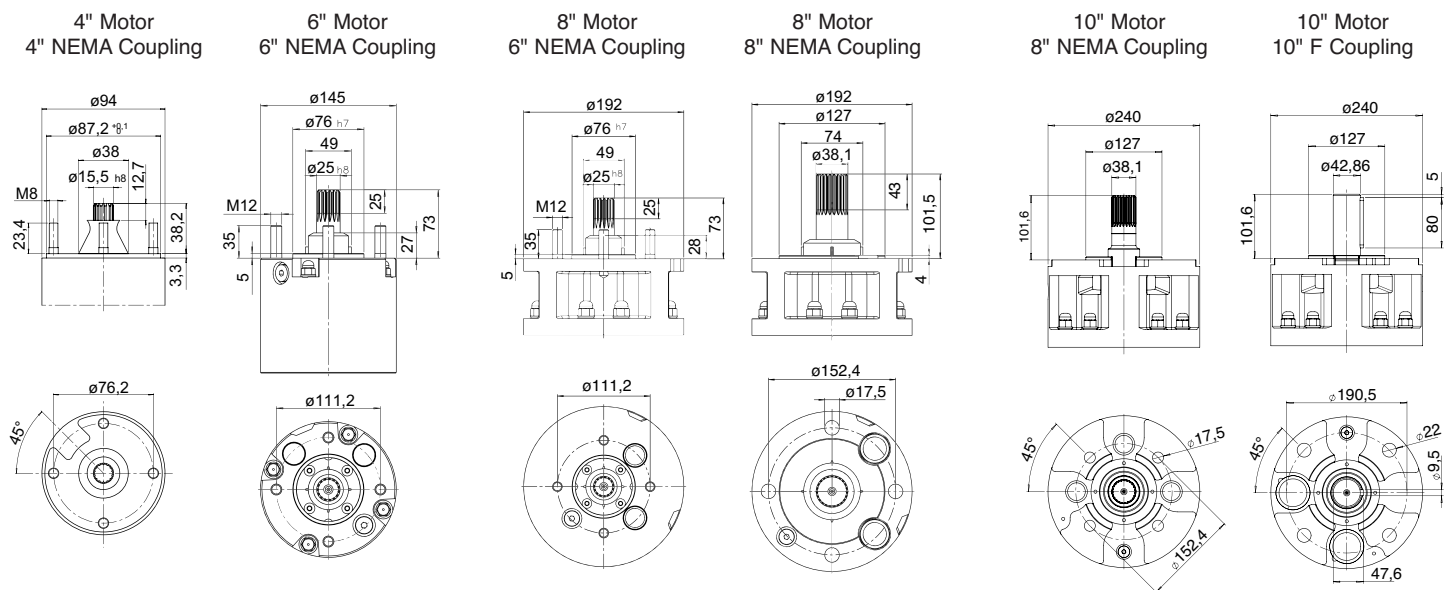

### Maximum length of electric cables

IN A	230 Volt - 50 Hz - 1 ~				
	1 four-wires cable 4 x ....mm <sup>2</sup>				
	1,5	2,5	4	6	10
	cables max m				
2	142	235			
4	71	118	189		
6	47	78	126	189	
8	35	59	94	142	231
10	28	47	76	113	185
12	24	39	63	95	154
14	20	34	54	81	132
16	18	29	47	71	115
18		26	42	63	103
20		24	38	57	92
25			30	45	74
30			25	38	62

Voltage drop 3%.  
Maximum ambient temperature + 30 °C.

### Direct-starting

IN A	230 Volt - 50 Hz - 3 ~																											
	1 four-wires cable 4 x ....mm <sup>2</sup>							4 cables 1 x ....mm <sup>2</sup>																				
	1,5	2,5	4	6	10	16	25	35	50	70	95	120	150															
	cables max m																											
2	164	272																										
4	82	136	218																									
6	55	91	145	218																								
8	41	68	109	164	267																							
10	33	54	87	131	213																							
12	27	45	73	109	178																							
14	23	39	62	94	152	239																						
16	20	34	55	82	133	209																						
18		30	48	73	118	186																						
20		27	44	65	107	167	257																					
25			35	52	85	134	206																					
30			29	44	71	111	171	233																				
35				37	61	95	147	200																				
40				33	53	83	129	175	227																			
45					47	74	114	155	202																			
50						43	67	103	140	181	249																	
60							56	86	116	151	207																	
70								48	73	100	130	178	230															
80									64	87	113	155	201	241														
90										57	78	101	138	179	214													
100											51	70	91	124	161	193	224											
110												64	82	113	146	175	203											
120													58	76	104	134	161	186										
130														70	96	124	148	172										
140															65	89	115	138	160									
150																60	83	107	128	149								
160																	57	78	101	120	140							
170																		53	73	95	113	132						
180																			50	69	89	107	124					
190																				48	65	85	101	118				
200																					45	62	81	96	112			
220																						57	73	88	102			
240																							52	67	80	93		
260																								62	74	86		
280																									58	69	80	
300																										54	64	75

IN A	400 Volt - 50 Hz - 3 ~																																		
	1 four-wires cable 4 x ....mm <sup>2</sup>								4 cables 1 x ....mm <sup>2</sup>																										
	1,5	2,5	4	6	10	16	25	35	50	70	95	120	150	185	240																				
	cables max m																																		
2	285	473																																	
4	143	236	379																																
6	95	158	253																																
8	71	118	190	285																															
10	57	95	152	228																															
12	48	79	126	190	309																														
14	41	68	108	163	265																														
16	36	59	95	142	232																														
18		53	84	127	206	323																													
20			47	76	114	185	290																												
25				61	91	148	232	358																											
30					51	76	124	194	298																										
35						65	106	166	256	347																									
40							57	93	145	224	304																								
45								82	129	199	270																								
50									74	116	179	243	316																						
60										97	149	203	263																						
70											83	128	174	225	309																				
80												112	152	197	270																				
90													99	135	175	240	311																		
100														89	122	158	216	280																	
110															110	143	197	255	305																
120																101	132	180	233	279															
130																	121	166	216	258	299														
140																		113	155	200	239	278													
150																			105	144	187	223	259	302											
160																				99	135	175	209	243	283										
170																					93	127	165	197	229	267									
180																						88	120	156	186	216	252	297							
190																							83	114	147	176	205	239	281						
200																								79	108	140	168	195	227	267					
220																										98	127	152	177	206	243				
240																											90	117	140	162	189	223			
260																													108	129	150	174	206		
280																														100	120	139	162	191	
300																															93	112	130	151	178

### Maximum length of electric cables

#### Star-delta starting

IN A	230 Volt - 50 Hz - 3 ~ Y/Δ													
	2 four-wires cables 4 G ....mm <sup>2</sup>							7 cables 1 x ....mm <sup>2</sup>						
	1,5	2,5	4	6	10	16	25	35	50	70	95	120	150	
cables max m														
30	19	31	50	76	123	193								
35		27	43	65	105	165								
40		24	38	57	92	144								
45		21	34	50	82	128	198							
50			30	45	74	116	178							
60				38	62	96	148	201						
70				32	53	83	127	173	224					
80					46	72	111	151	196					
90					41	64	99	134	174					
100						58	89	121	157	215				
110						53	81	110	143	196				
120						48	74	101	131	179				
130						44	68	93	121	166	214			
140							64	86	112	154	199			
150							59	81	105	143	186			
160							56	76	98	134	174	208		
170							52	71	92	127	164	196		
180								67	87	120	155	185		
190								64	83	113	147	175	204	
200									78	108	139	167	194	
220										98	127	152	176	
240										90	116	139	161	
260										83	107	128	149	
280										77	100	119	138	
300										72	93	111	129	

IN A	400 Volt - 50 Hz - 3 ~ Y/Δ													
	2 four-wires cables 4 G ....mm <sup>2</sup>							7 cables 1 x ....mm <sup>2</sup>						
	1,5	2,5	4	6	10	16	25	35	50	70	95	120	150	
cables max m														
30		33	55	88	131	214	335							
35			47	75	113	183	287							
40			41	66	99	160	251							
45				58	88	143	223	344						
50				53	79	128	201	310						
60					66	107	167	258	350					
70					56	92	144	221	300					
80						80	126	193	263	341				
90						71	112	172	234	303				
100						64	100	155	210	273	374			
110						58	91	141	191	248	340			
120							84	129	175	228	312			
130							77	119	162	210	288	373		
140								111	150	195	267	346		
150								103	140	182	249	323		
160								97	131	171	234	303	362	
170									124	161	220	285	341	
180									117	152	208	269	322	
190									111	144	197	255	305	354
200										137	187	242	290	337
220											170	220	264	306
240											156	202	242	280
260												186	223	259
280												173	207	240
300												162	193	224

- Against short-circuits and overloads to the electric pumps system we advise to follow the usually applied normative.
- To avoid a possible dry working of the electric pump in is better to install a level control.
- In order to avoid overheatings, tension drops above 3%, we advise to use suitable starting motors systems.
- All the cable wave to respect the usually applied normative and to present excellent insulation characteristics.

The tables show the maximum length of the cable depending on the current absorbed by the motor and the cross section area of the cable, at different voltages. The maximum voltage drop equal to 3%, cable temperature of 80°C, water installation similar to air installation at a temperature of 30°C.



### Choice of electric cable by calculation

For dimensioning the phase cross section area for the submersible motor need the following information:

- V: Rated voltage (V)
- I: Motor current (A)
- L: Length of cable (km)
- cos φ: power factor
- Ambient temperature (°C)

The choice of the minimum cross section area of the phase conductor is determined by the rated motor current and the values reported in Table 1.

Table 1

Type of cable*	Cable cross section mm <sup>2</sup>	Maximum cable current		Resistance R at 80°C ohm/km <sup>4)</sup>	Reactance X at 50Hz ohm/km <sup>4)</sup>
		1 Ader A <sup>1)</sup>	2 Ader A <sup>3)</sup>		
four-wires cable	1.5	18		15.1	0,142
four-wires cable	2.5	24		9.08	0,131
four-wires cable	4	32		5.63	0,121
four-wires cable	6	41		3.73	0,115
four-wires cable	10	57		2.27	0,103
four-wires cable	16	76		1.43	0,098
four-wires cable	25	96		0.91	0,097
four-wires cable	35		119	0.65	0,094
single-wire cable	50		167	0.473	0,121
single-wire cable	70		216	0.328	0,116
single-wire cable	95		264	0.236	0,118
single-wire cable	120		308	0.188	0,113
single-wire cable	150		356	0.153	0,112
single-wire cable	185		409	0.123	0,109
single-wire cable	240		485	0.094	0,110

<sup>1)</sup> IEC 60364-5-52:2009 Tab.B52.4 / C

<sup>2)</sup> IEC 60364-5-52:2009 Tab.B52.6

<sup>3)</sup> 1)×0,85 IEC 60364-5-52:2009 Tab.B52.17 ITEM2

<sup>4)</sup> UNEL 35023-70

\* Up to 35 mm<sup>2</sup> sections four-wire cable are used, from 50 mm<sup>2</sup> single core cables are recommended as well.Tab.1

The maximum current of the cables listed in Table 1 are for ambient temperature of 30 ° C.

When the temperature is different, the maximum current of the cables should be corrected by a factor given in Table 2.

Table 2 (IEC 60364-5-52:2009 Tab.B.52.14)

Ambient Temperature °C	10	15	20	25	30	35	40	45	50	55	60
Correction factor	1,22	1,17	1,12	1,06	1	0,94	0,87	0,79	0,71	0,61	0,5

The cross section area of the phase conductor is chosen by checking the voltage drop along the line , through the following equation:

$$DU\% = 1,73 \cdot I \cdot L \cdot (R \cdot \cos \varphi + X \cdot \sin \varphi) / (V \cdot 1000)$$

DU% the voltage drop should not be greater than 3%

R, X = cable resistance and reactance in ohms/km (indicated in Table 1)

$$\sin \varphi = \sqrt{1 - (\cos \varphi)^2}$$

In case of star / delta starting the rated current of the motor should be divided by 1.73.

Determination of minimal sections of the protective conductor PE.

Table 3 (CEI 64-8:2007 Tab.54F)

Phase cross section area S mm <sup>2</sup>	PE cross section area S <sub>PE</sub> mm <sup>2</sup>
S ≤ 16	S
16 < S ≤ 25	16
S > 25	S/2



### Electric control panels

#### M COMP Control panel for 1 single-phase submersible pump



Type	Protector max A	Capacitor 450Vc	Motor 230V - 1~ kW	Dimensions HxBxP mm
M COMP 4-16	4,5	16 µF	0,37	220x210x110
M COMP 4-20	4,5	20 µF	0,55	220x210x110
M COMP 5-20	5	20 µF	0,55	220x210x110
M COMP 5-25	5	25 µF	0,55	220x210x110
M COMP 6-20	6	20 µF	0,75	220x210x110
M COMP 6-35	6	35 µF	0,9	220x210x110
M COMP 7-25	7	25 µF	0,9	220x210x110
M COMP 7-30	7	30 µF	0,9	220x210x110
M COMP 8-25	8	25 µF	1,1	220x210x110
M COMP 8-30	8	30 µF	1,1	220x210x110
M COMP 10-35	10	35 µF	1,1	220x210x110
M COMP 10-40	10	40 µF	1,1	220x210x110
M COMP 12-35	12	35 µF	1,5	220x210x110
M COMP 12-50	12	50 µF	1,5	220x210x110
M COMP 12-60	12	60 µF	1,5	220x210x110
M COMP 16-70	16	70 µF	2,2	220x210x110

#### Construction

Control panel with ON-OFF switch and capacitor for 1 submersible pump with single-phase motor. Suitable for use with LVBT board for level control.

Protection is provided by means of a main bipolar switch with a phase protected against overload by means of a thermal element.

#### PFC-M Control panel for 1 submersible pump with single-phase motor, PF control



Type	Setting A	Capacitor 450Vc	Motor 50/60Hz 220V-240V - 1~ kW	Dimensions HxBxP mm
PFC-M 18-16	1 - 18	16 µF	0,37	220x210x110
PFC-M 18-20	1 - 18	20 µF	0,55	220x210x110
PFC-M 18-25	1 - 18	25 µF	0,55	220x210x110
PFC-M 18-30	1 - 18	30 µF	0,75	220x210x110
PFC-M 18-35	1 - 18	35 µF	0,75	220x210x110
PFC-M 18-40	1 - 18	40 µF	1,1	220x210x110
PFC-M 18-50	1 - 18	50 µF	1,5	220x210x110
PFC-M 18-60	1 - 18	60 µF	1,5	220x210x110
PFC-M 18-70	1 - 18	70 µF	2,2	220x210x110

#### Construction

Control panel for controlling one submersible pump with single-phase motor. Electronic control of the operation and dry-running protection through the power factor (PF) control.

The installation of level probes into the well is not required.

It stops the pump in case of lack of air cushion in the pressure vessel (patented system).

Displayed operating data and alarms available in four languages.

#### QML/A 1 D Control panel for 1 pump with single-phase motor, direct starting



Type	Motor 230V - 1~ kW	Setting A	Dimensions HxBxP mm
QML/A 1 D 12A-FA	0,25 - 1,5	1 - 12	250x205x105
QML/A 1 D 12A-FA 20	0,25 - 1,5	1 - 12	250x205x105
QML/A 1 D 12A-FA 25	0,25 - 1,5	1 - 12	250x205x105
QML/A 1 D 3 FT	2,2 - 3	13 - 18	400x300x160

#### Construction

Control panel for 1 pump with single-phase motor, direct starting for pressure booster sets, with a patented working time-measuring system that stops the pump in case of lack of air cushion in the pressure vessel.

Arranged for the capacitor internal connection (for pumps without built-in capacitor).

Pump operation controlled by an electronic board type MPS 3000 with microprocessor which allows three different modes of operation of the pump: standard, emergency and timed.

#### T COMP Control panel for 1 submersible pump with three-phase motor



Type	Protector A	Motor 230V - 3~ kW	Motor 400V - 3~ kW	Dimensions HxBxP HxBxP mm
T COMP 8	1 ÷ 8	0,37 ÷ 1,5	0,5 ÷ 2,2	170x145x85
T COMP 10	7 ÷ 10	---	3 ÷ 3,7	230x180x155
T COMP 12	9 ÷ 12	2,2	4	230x180x155
T COMP 16	11 ÷ 16	3	5,5	230x180x155
T COMP 20	14 ÷ 20	3,7 - 4	7,5	230x180x155

#### Construction

Control panel and protection for 1 submersible pump with three-phase motor.

Arranged for the LVBT level control internal connection against dry running (T COMP8 model has the level control as a standard).

Control pumps with pressure switch and float-type switch.

### Electric control panels

#### PFC-T Control panel for 1 submersible pump with three-phase motor, PF control



Type	Motor 400V - 3~ kW	Setting A	Dimensions HxBxP mm
PFC-T 16/A	0,37 - 5,5	1 - 16	250x205x105

#### Construction

Control panel for controlling 1 submersible pump with three-phase motor. Electronic control of the operation and dry-running protection through the power factor (PF) control.

The installation of level probes into the well is not required.

It stops the pump in case of lack of air cushion in the pressure vessel (patented system) Displayed operating data and alarms, available in four languages.

#### QTL/A 1 D Control panel for 1 pump with three-phase motor, direct starting



Type	Motor 400V - 3~ kW	Setting A	Dimensions HxBxP mm
QTL/A 1 D 12A-FA	0,25 - 5,5	1 - 12	250x205x105
QTL/A 1 D 7,5 FT	7,5	13 - 18	400x300x160
QTL/A 1 D 9,2 FT	9,2	17 - 23	400x300x160
QTL/A 1 D 11 FT	11	20 - 25	400x300x160

#### Construction

Control panel for 1 pump with three-phase motor, direct starting for pressure booster sets, with a patented working time-measuring system that stops the pump in case of lack of air cushion in the pressure vessel.

Pump operation controlled by an electronic card type MPS 3000 with microprocessor which allows three different modes of operation of the pump: standard, emergency and timed.

Dry-running protection with float switch.

#### QTL 1 D FTE Control panel for 1 pump with three-phase motor, direct starting



Type	Motor 400V - 3~ kW	Setting A	Dimensions HxBxP mm
QTL 1 D 4 FTE	4	6,3 - 10	400x300x160
QTL 1 D 5,5 FTE	5,5	9 - 12	400x300x160
QTL 1 D 7,5 FTE	7,5	13 - 18	400x300x160
QTL 1 D 9,2 FTE	9,2	17 - 23	400x300x160
QTL 1 D 11 FTE	11	20 - 25	400x300x160
QTL 1 D 15 FTE	15	24 - 32	500x350x200
QTL 1 D 18,5 FTE	18,5	32 - 38	500x350x200
QTL 1 D 22 FTE	22	35 - 50	500x350x200
QTL 1 D 30 FTE	30	46 - 65	500x350x200

#### Construction

Electromechanical control panel for 1 pump with three-phase motor, direct starting.

Operating signals by E 1000 led card.

Dry-running protection with float switch.

Construction with SRLE level control for probes connection against dry-running on request .

#### QTL/A 1 ST FT Control panel for 1 pump with three-phase motor, Y/Δ starting



Type	Motor Power kW	400V - 3~ Current A	Dimensions HxBxP mm
QTL/A 1 ST 5,5 FT	5,5	11 - 15	600x400x200
QTL/A 1 ST 7,5 FT	7,5	12 - 17	600x400x200
QTL/A 1 ST 11 FT	9,2 - 11	16 - 24	600x400x200
QTL/A 1 ST 15 FT	15	23 - 31	600x400x200
QTL/A 1 ST 18,5 FT	18,5	30 - 39	600x400x200
QTL/A 1 ST 22 FT	22	35 - 43	700x500x200
QTL/A 1 ST 30B FT	30	42 - 55	700x500x200
QTL/A 1 ST 30A FT	30	55 - 65	700x500x200
QTL/A 1 ST 37 FT	37	61 - 84	800x600x250
QTL/A 1 ST 45 FT	45	80 - 105	800x600x250

#### Construction

Control panel for 1 pump with three-phase motor, Y/Δ starting for pressure booster sets, with a patented working time-measuring system that stops the pump in case of lack of air cushion in the pressure vessel.

Pump operation controlled by an electronic card type MPS 3000 with microprocessor with different pump operating modes.

Dry-running protection with float switch or level control probes.

### Electric control panels

#### QTL 1 ST FTE Control panel for 1 pump with three-phase motor, Y/Δ starting

Type	Motor 400V - 3~		Dimensions HxBxP mm
	Power kW	Current A	
QTL 1 ST 5,5 FTE	5,5	11 - 15	500x350x200
QTL 1 ST 7,5 FTE	7,5	12 - 17	500x350x200
QTL 1 ST 11 FTE	9,2 - 11	16 - 24	500x350x200
QTL 1 ST 15 FTE	15	23 - 31	500x350x200
QTL 1 ST 18,5 FTE	18,5	30 - 39	500x350x200
QTL 1 ST 22 FTE	22	35 - 43	600x400x200
QTL 1 ST 30B FTE	30	42 - 55	600x400x200
QTL 1 ST 30A FTE	30	55 - 65	600x400x200
QTL 1 ST 37 FTE	37	61 - 84	700x500x200
QTL 1 ST 45 FTE	45	80 - 105	700x500x200
QTL 1 ST 55 FTE	55	100 - 125	700x500x200
QTL 1 ST 75 FTE	75	120 - 160	800x600x250
QTL 1 ST 92 FTE	92	140 - 198	800x600x250
QTL 1 ST 110 FTE	110	180 - 250	800x600x250

#### Construction

Electromechanical control panel for 1 pump with three-phase motor, Y/Δ starting.  
 Operating signals by E 1000 led board.  
 Dry-running protection with float switch.  
 Construction with SRLE level control for probes connection against dry-running on request .

#### QTL 1 SS E Control panel for 1 pump with three-phase motor, start/stop with soft starter

Type	Motor 400V - 3~ kW	Max current output max A	Dimensions HxBxP mm
QTL 1 SS 7,5 E	7,5	17	700x500x250
QTL 1 SS 15 E	9,2 - 11 - 15	30	700x500x250
QTL 1 SS 22 E	18,5 - 22	45	700x500x250
QTL 1 SS 30 E	26 - 30	60	900x600x300
QTL 1 SS 37 E	37	75	900x600x300
QTL 1 SS 45 E	45	85	900x600x300
QTL 1 SS 55 E	55	110	900x600x300
QTL 1 SS 63 E	63	125	1100x700x300
QTL 1 SS 75 E	75	142	1100x700x300
QTL 1 SS 90 E	90	190	1200x800x400
QTL 1 SS 132 E	110 - 132	245	1200x800x400

#### Construction

Control panel for 1 pump with three-phase motor, start/stop with soft starter.  
 Operating signals on E 1000 led board.  
 Application: control of submersible motor with great cable length and surface motors.  
 Dry-running protection with float switch.  
 Construction with SRLE level control for probes connection against dry-running on request .

#### QTL 1 IS FTE Control panel for 1 pump with three-phase motor, with Stator Impedance starter

Type	Motor 400V - 3~		Dimensions HxBxP mm
	Power kW	Current A	
QTL 1 IS 5,5 FTE-2RL	5,5	11 - 15	
QTL 1 IS 7,5 FTE-2RL	7,5	12 - 17	
QTL 1 IS 11 FTE-2RL	9,2 - 11	16 - 24	
QTL 1 IS 15 FTE-2RL	15	23 - 31	
QTL 1 IS 18,5 FTE-2RL	18,5	30 - 39	
QTL 1 IS 22 FTE-2RL	22	35 - 43	
QTL 1 IS 30 FTE-2RL	30	42- 65	
QTL 1 IS 37 FTE-2RL	37	61 - 84	
QTL 1 IS 45 FTE-2RL	45	80 - 105	
QTL 1 IS 55 FTE-2RL	55	100 - 125	
QTL 1 IS 75 FTE-2RL	75	120 - 160	
QTL 1 IS 92 FTE-2RL	92	140 - 198	
QTL 1 IS 110 FTE-2RL	110	180 - 250	

#### Construction

Electromechanical control panel for 1 submersible pump with three-phase motor, with Stator Impedance starter.  
 Operating signals on led board type E 1000.  
 Application : submersible motors control with great cable length.  
 Construction with SRLE level control for probes connection against dry-running .

### Electric control panels

#### QML 1 VFT Control panel for 1 pump with variable speed three-phase motor



Type	Motor 230V - 3~ kW	Max current output max A	Dimensions HxBxP mm
QML 1 VFT 0,4	0,37 - 0,45	2,4	500x350x200
QML 1 VFT 0,75	0,55 - 0,75	4,2	500x350x200
QML 1 VFT 1,5	1,1 - 1,5	7,5	500x350x200
QML 1 VFT 2,2	2,2	10	500x350x200

#### Construction

**Single-phase mains supply** control panel with frequency converter for 1 pump with three-phase variable speed motor, for constant pressure booster sets.

Arranged for SRL 3 level control application for probes connection against dry-running.

Pump operation controlled by an electronic board type MPS 4000 with microprocessor.

#### QTL 1 VFT Control panel for 1 pump with variable speed three-phase motor



Type	Motor 400V - 3~ kW	Max current output max A	Dimensions HxBxP mm
QTL 1 VFT 0,4	0,4	1,5	500x350x200
QTL 1 VFT 0,75	0,55 - 0,75	2,3	500x350x200
QTL 1 VFT 1,5	1,1 - 1,5	4,1	500x350x200
QTL 1 VFT 2,2	2,2	5,5	500x350x200
QTL 1 VFT 4	3 - 4	9,5	500x350x200
QTL 1 VFT 5,5	5,5	14,3	600x400x250
QTL 1 VFT 7,5	7,5	17	600x400x250
QTL 1 VFT 11	9,2 - 11	27,7	700x500x250
QTL 1 VFT 15	15	33	700x500x250
QTL 1 VFT 18,5	18,5	46,3	800x600x250
QTL 1 VFT 22	22	61,5	800x600x250
QTL 1 VFT 30	30	74,5	900x600x250
QTL 1 VFT 37	37	88	1100x700x300
QTL 1 VFT 45	45	106	1200x800x300
QTL 1 VFT 55	55	145	1200x800x300
QTL 1 VFT 75	75	173	1200x800x300

#### Construction

Control panel with frequency converter for 1 pump with three-phase variable speed motor, for constant pressure booster sets.

Arranged for SRL 3 level control application for probes connection against dry-running.

Pump operation controlled by an electronic board type MPS 4000 with microprocessor.