

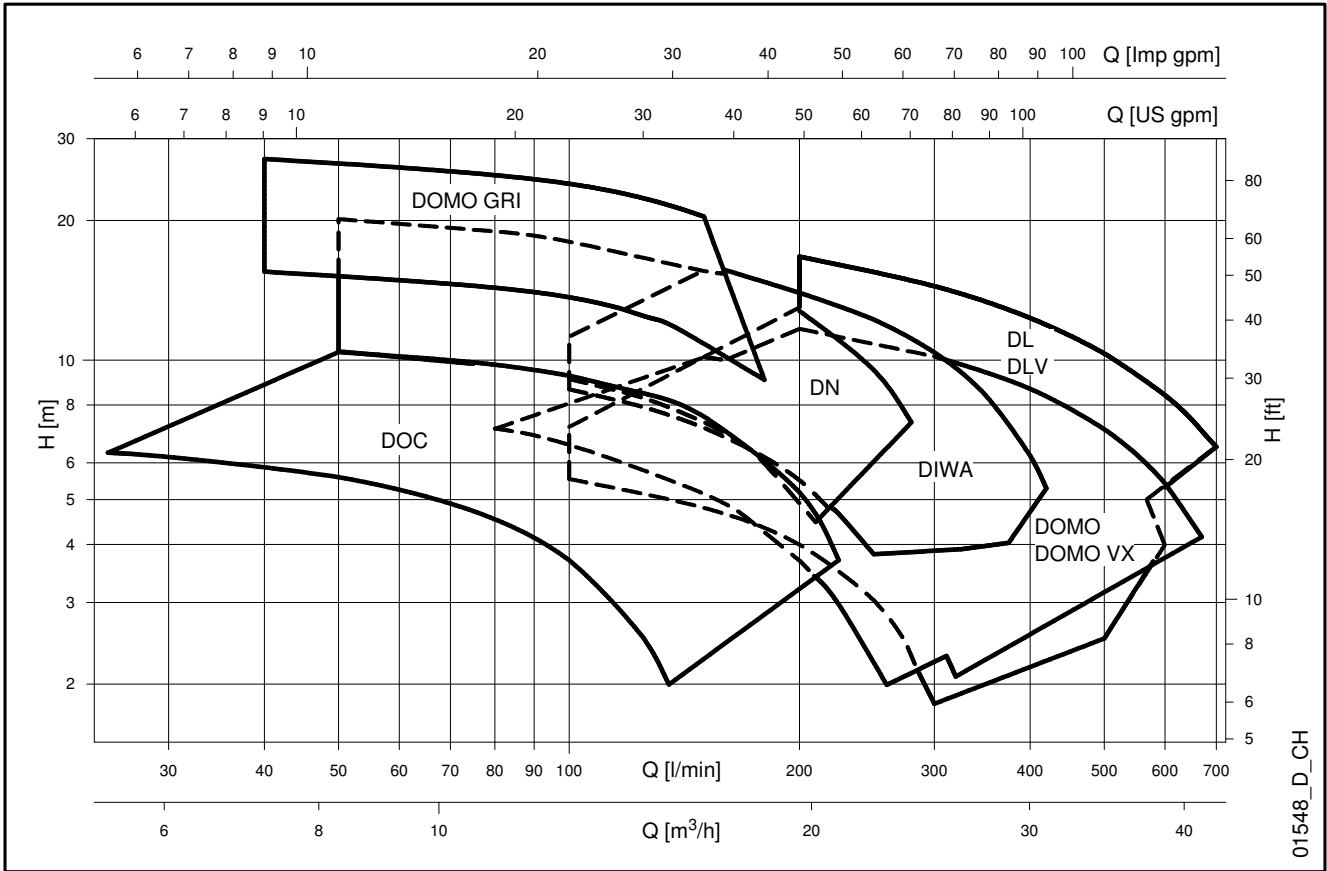

DOC - DIWA - DOMO DOMO GRI - DN - DL Series

DRAINAGE AND SEWAGE ELECTRIC PUMPS

**DOC - DIWA - DOMO - DOMO GRI - DN - DL SERIES
HYDRAULIC PERFORMANCE RANGE AT 50 Hz**



CONTENTS

DOC Series	5
SPECIFICATIONS	5
TABLE OF MATERIALS	7
OPERATING CHARACTERISTICS AT 50 Hz	8
DIMENSIONS AND WEIGHTS	9
DIWA Series.....	11
SPECIFICATIONS	11
TABLE OF MATERIALS	13
MECHANICAL SEAL	14
OPERATING CHARACTERISTICS AT 50 Hz	15
DIMENSIONS AND WEIGHTS	16
DOMO and DOMO GRI Series	19
SPECIFICATIONS	19
TABLE OF MATERIALS	22
MECHANICAL SEAL	24
OPERATING CHARACTERISTICS AT 50 Hz	25
DIMENSIONS AND WEIGHTS	28
DN Series.....	33
SPECIFICATIONS	33
TABLE OF MATERIALS	35
MECHANICAL SEAL	36
OPERATING CHARACTERISTICS AT 50 Hz	37
DIMENSIONS AND WEIGHTS	38

CONTENTS

DL Series	39
SPECIFICATIONS	39
LIST OF MODELS AND TABLE OF MATERIALS	41
MECHANICAL SEAL	43
OPERATING CHARACTERISTICS AT 50 Hz	45
DIMENSIONS AND WEIGHTS	47
TECHNICAL APPENDIX.....	49

Submersible Electric Pumps for drainage of clean and dirty water

DOC Series



DOC pumps are versatile, corrosion-resistant and compact. Three basic versions are available with 0,25 to 0,55 kW power. A DOC 7VX version with Vortex impeller is available.

APPLICATIONS

- Emptying of residential sump pits, rainwater tanks or laundry drainage.
- Garden and lawn irrigation, with suction from rainwater tanks.
- Emergency draining of flooded basements and garages.
- Transfer of water from tanks and basins.

SPECIFICATIONS

- **Maximum liquid temperature: 40°C.**
- **Dry motor** cooled by the pumped liquid.
- **Power cord:**
 - single-phase: with plug.
 - three-phase: without plug.
- **Insulation class 130°C (B).**
- **IPX8 protection.**
- **Maximum immersion depth: 5 m.**
- The **DOC3** pump features a flow rate up to **135 l/min**, head up to **7 m**, and passes **suspended solids up to 10 mm** in diameter. Only available in single-phase version.
- The **DOC7** pump features a flow rate up to **225 l/min**, head up to **11 m**, and passes **suspended solids up to 10 mm** in diameter.
- The **DOC7VX** pump features a flow rate up to **175 l/min**, head up to **7 m**, and can handle liquids with **suspended solids up to 20 mm** in diameter.
- **Versions:**
 - Single-phase: 220-240V, 50Hz 2 poles.
 - Three-phase: 220-240V, 50Hz 2 poles. 380-415V, 50Hz 2 poles.
- **The single-phase versions** feature:
 - **pre-assembled float switch** for automatic pump operation.
 - **built-in capacitor.**
 - **thermal overload protection** to stop pump supply in case of overheating.
- SG versions (single-phase without float switch), GW versions (single-phase with bell float switch), 60 Hz single-phase and three-phase versions, versions with various power cord lengths and various plugs are available on request.
- A "**shallow-suction device**", that can be mounted on both the DOC3 and DOC7 models, is available on request. It ensures the complete drainage of flooded floors (down to 3 mm from floor).
- **SOS KIT**
 - The **SOS Kit** is available, for quick emergency dewatering of flooded basements, garages and residential buildings.
 - The kit is composed of:
 - a single-phase **DOC3** electric pump, equipped with float switch, 10 meters power cord with plug and a quick coupling already mounted for rapid hose connection.
 - 6 meters long **flexible hose**, complete with quick coupling already mounted for rapid pump connection.
 - **plastic box** that can be used to store the kit on a shelf when not in use, or as a strainer during operation.

DOC SERIES IDENTIFICATION CODE

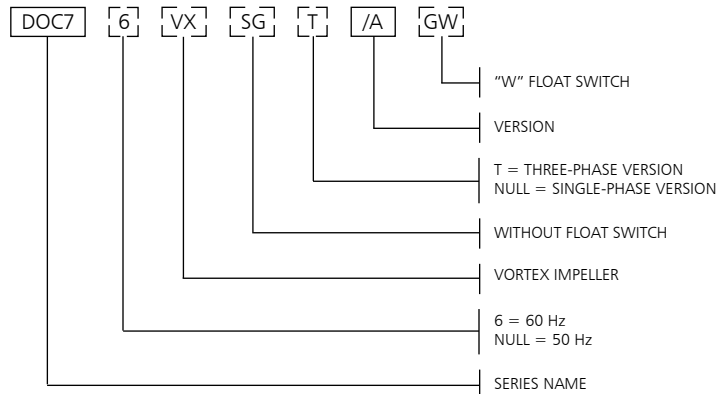

EXAMPLE : DOC 7VX/A
DOC 7 Series Electric pump, 50 Hz version,
Vortex impeller, single-phase, /A version.

SINGLE-PHASE RATING PLATE

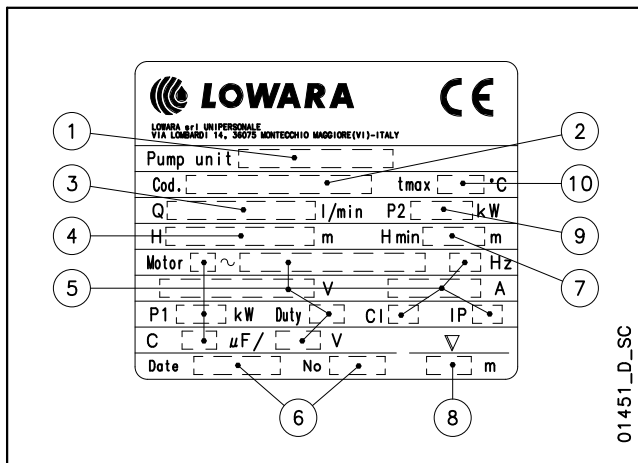

LEGEND

- 1 - Electric pump type
- 2 - Code
- 3 - Delivery range
- 4 - Head range
- 5 - Motor type
- 6 - Date of manufacture and serial number
- 7 - Minimum head
- 8 - Maximum immersion depth
- 9 - Rated output
- 10 - Maximum liquid temperature

THREE-PHASE RATING PLATE

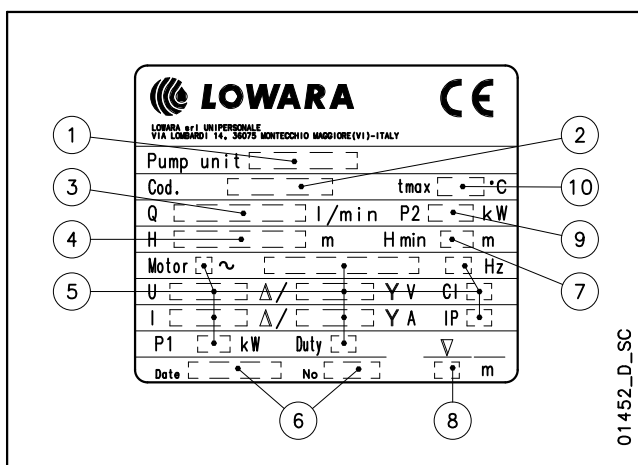

DOC SERIES
TABLE OF MATERIALS

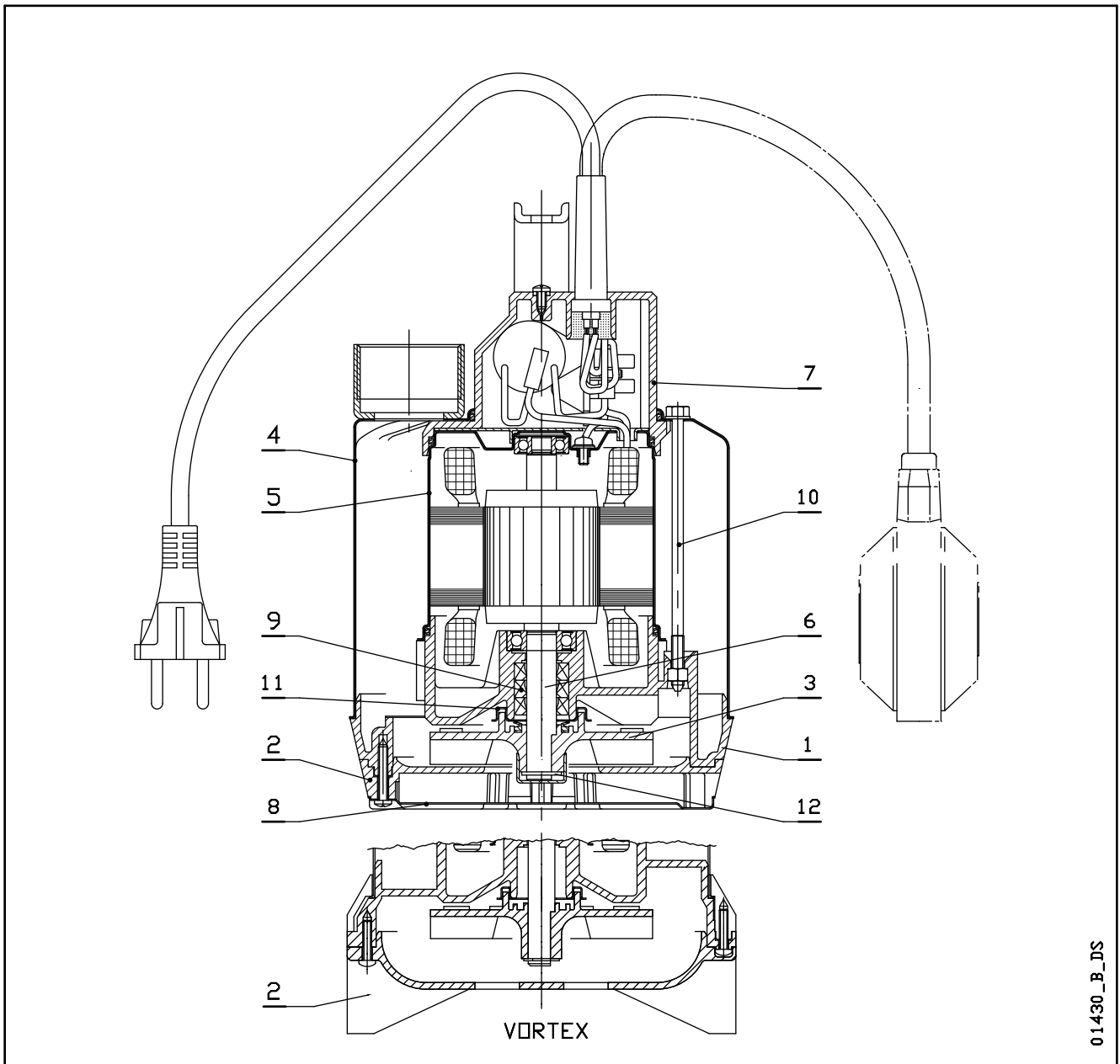

01430_B_DS

REF. N.	NAME	MATERIAL	REFERENCE STANDARDS	
			EUROPE	USA
1	Pump body	PPE + PS resin + 20 % GF		
2	Suction strainer	PPE + PS resin + 20 % GF		
	Lower support	PPE + PS resin + 20 % GF		
3	Impeller DOC3	PPE + PS resin + 20 % GF		
	Impeller DOC7 - DOC7VX	PA 66 + 30 % GF		
4	External case	Stainless steel	EN 10088-1-X5CrNi18-10 (1.4301)	AISI 304
5	Internal motor casing	Stainless steel	EN 10088-1-X5CrNi18-10 (1.4301)	AISI 304
6	Shaft	Stainless steel	EN 10088-1-X12CrS13 (1.4005)	AISI 416
7	Head	PPE + PS resin + 20 % GF		
8	Lower cover	Stainless steel	EN 10088-1-X5CrNi18-10 (1.4301)	AISI 304
9	Elastomers	NBR		
10	Tie-rod and screws	Stainless steel	EN 10088-1-X5CrNi18-10 (1.4301)	AISI 304
11	Double wear ring	Stainless steel	EN 10088-1-X5CrNi18-10 (1.4301)	AISI 304
12	Impeller fixing ring	Stainless steel	EN 10088-1-X5CrNi18-10 (1.4301)	AISI 304

DOC SERIES OPERATING CHARACTERISTICS AT 50 Hz

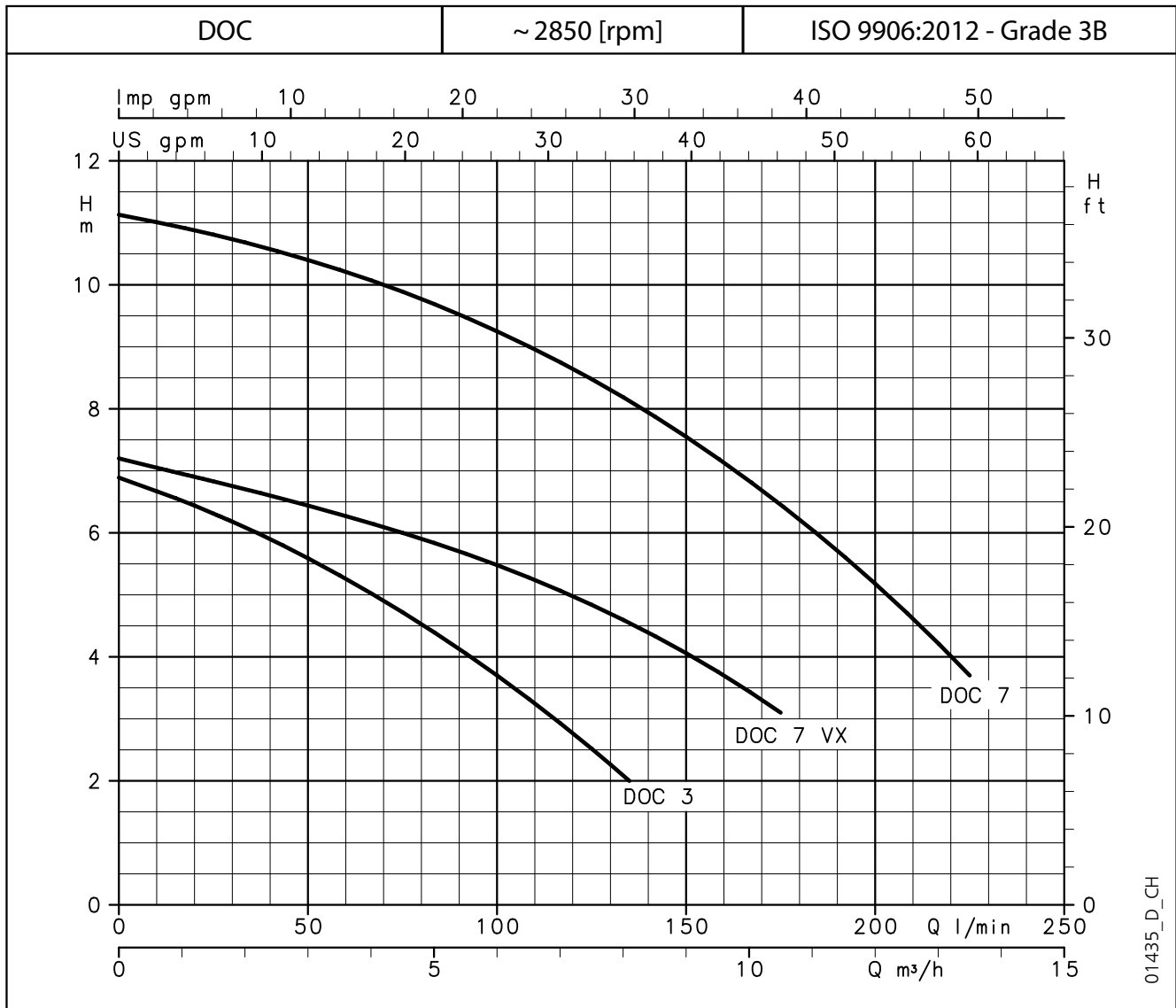

HYDRAULIC PERFORMANCE TABLE

PUMP TYPE	RATED POWER		Q = DELIVERY									
			l/min	0	25	50	75	100	125	135	175	225
	kW	HP	m ³ /h	0	1,5	3	4,5	6	7,5	8,1	10,5	13,5
	H = TOTAL HEAD METRES COLUMN OF WATER											
DOC3	0,25	0,33	6,9	6,3	5,6	4,7	3,7	2,5	2,0			
DOC7(T)	0,55	0,75	11,1	10,8	10,4	9,9	9,3	8,5	8,1	6,5	3,7	
DOC7VX(T)	0,55	0,75	7,2	6,8	6,4	6,0	5,5	4,8	4,5	3,1		

These performances are valid for liquids with density $\rho = 1,0 \text{ kg/dm}^3$ and kinematic viscosity $\nu = 1 \text{ mm}^2/\text{s}$.

doc-2p50-en_b_th

ELECTRICAL DATA TABLE

PUMP TYPE	ABSORBED POWER*	ABSORBED CURRENT*	CAPACITOR
SINGLE-PHASE	kW	A	$\mu\text{F} / 450 \text{ V}$
DOC 3	0,31	1,43	6,3
DOC 7	0,78	3,47	16
DOC 7VX	0,66	2,96	16

PUMP TYPE	ABSORBED POWER*	ABSORBED CURRENT*	ABSORBED CURRENT*
THREE-PHASE	kW	A	A
-	-	-	-
DOC 7T	0,79	2,82	1,63
DOC 7VXT	0,66	2,68	1,55

*Maximum values within operating range

doc-2p50-en_a_te

DOC SERIES DIMENSIONS AND WEIGHTS

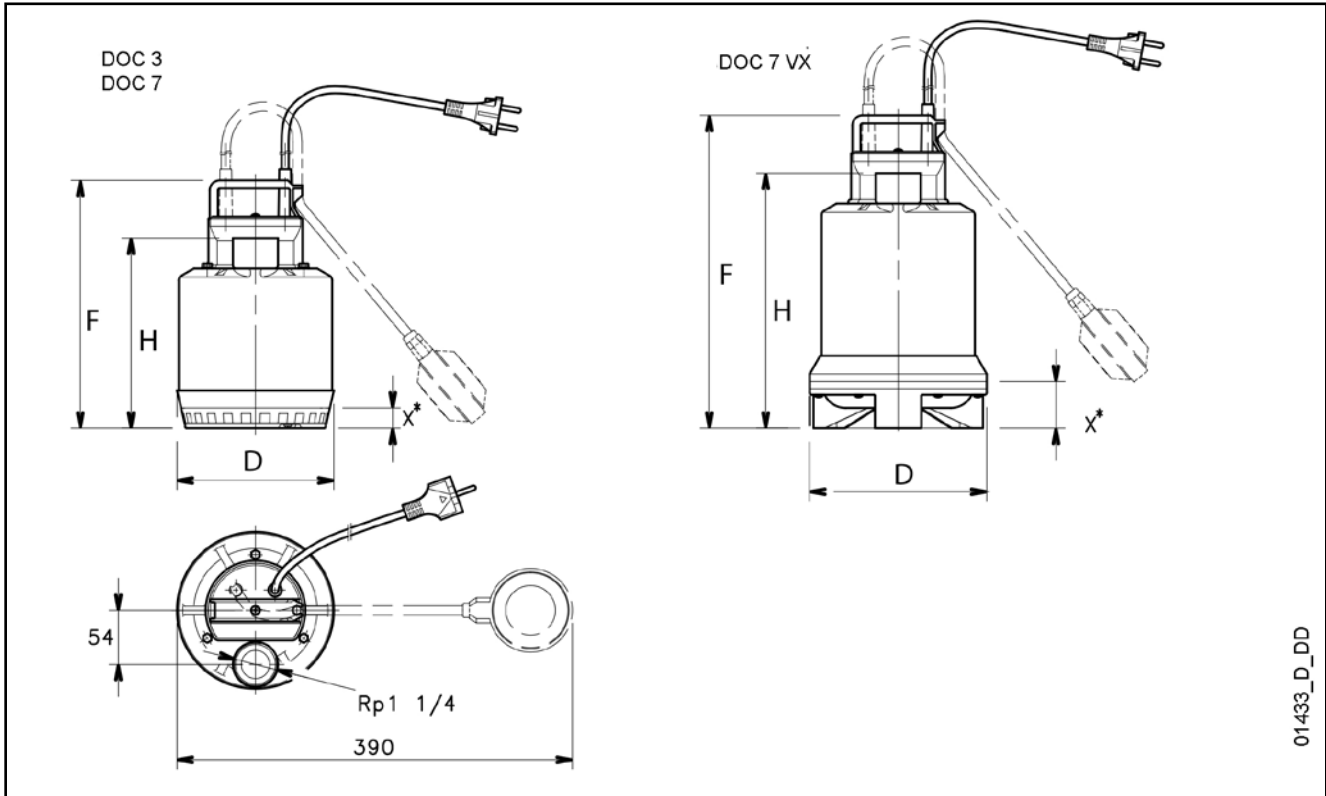

PUMP TYPE		DIMENSIONS (mm)				WEIGHT
		F	H	D	X*	kg
DOC3	DOC3 GW	245	188	155	20	4
DOC7	DOC7 GW	285	228	155	20	6
DOC7VX	-	310	252	175	45	6

* Minimum liquid level.

doc_doc gw-2p50-en_a_td

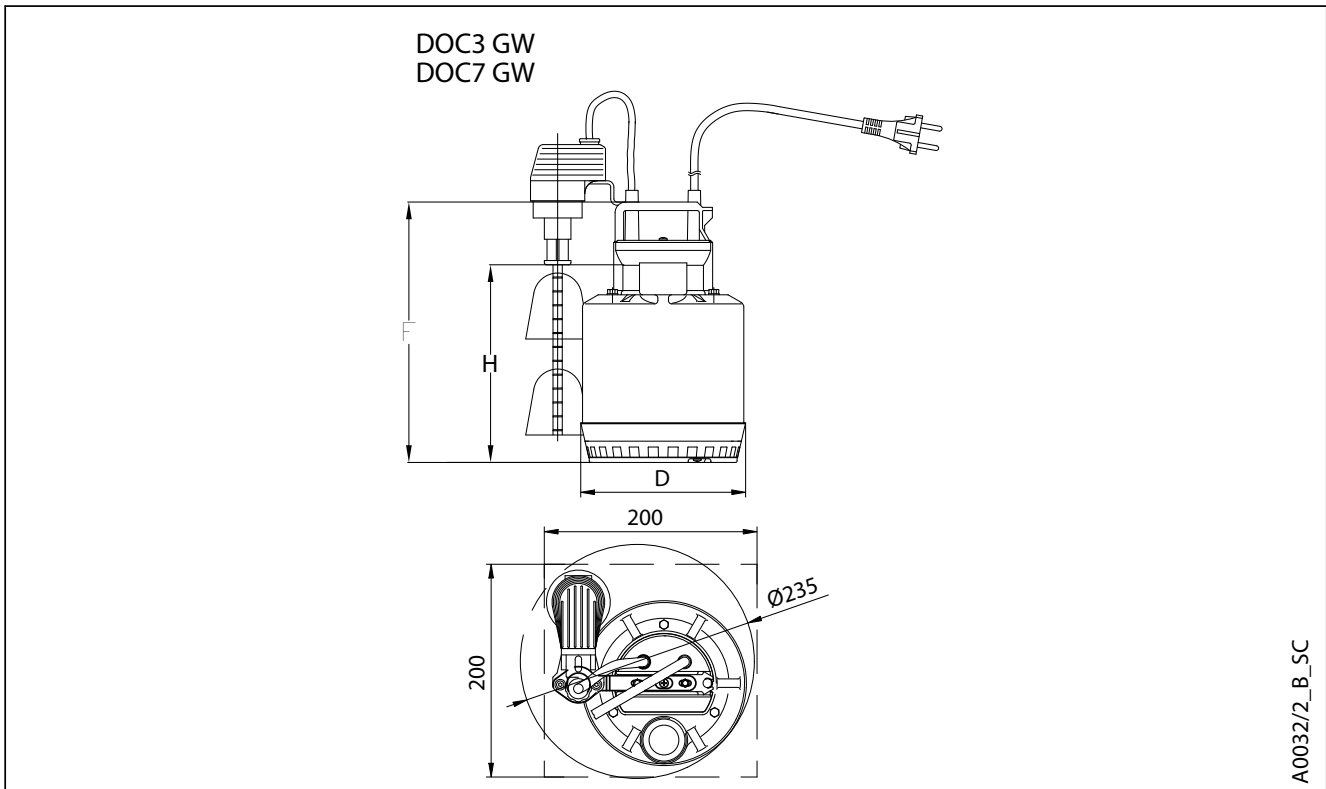

DOC SERIES INSTALLATION EXAMPLES

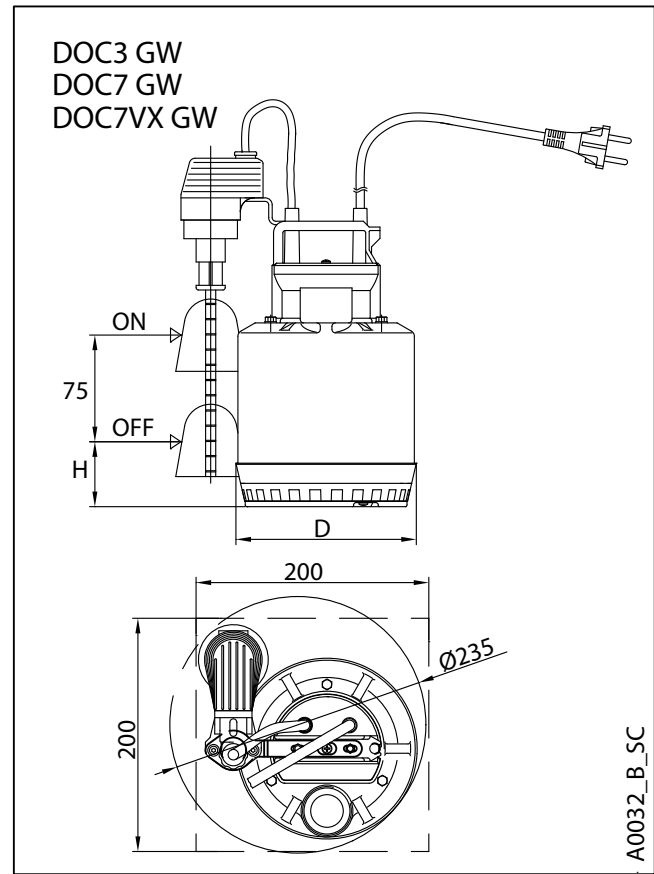
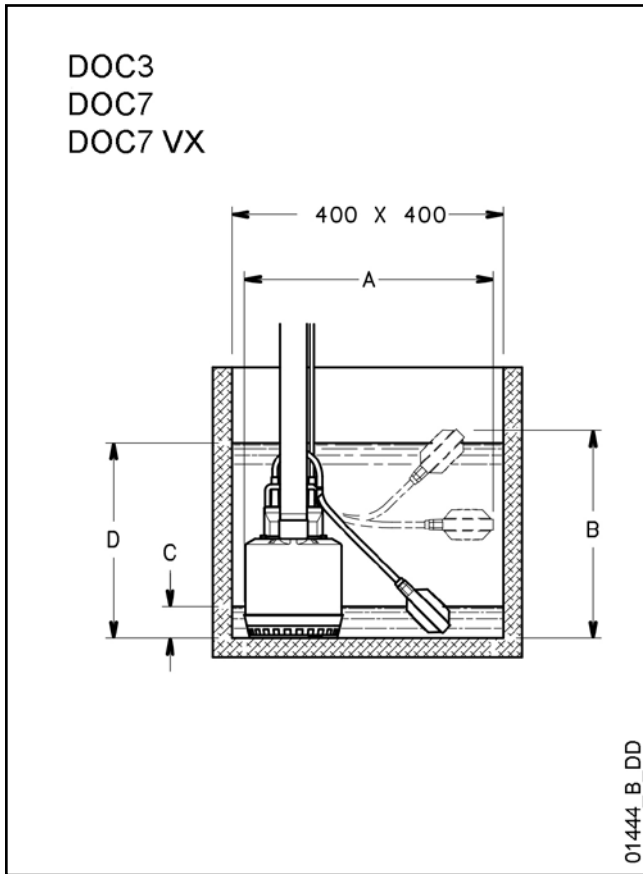

PUMP TYPE		DIMENSIONS (mm)		MINIMUM WATER LEVEL	MAXIMUM WATER LEVEL	MINIMUM WATER LEVEL
		A	B	C*	D*	H
DOC3	DOC3 GW	390	330	50	310	75
DOC7	DOC7 GW	390	370	90	350	75
DOC7VX	-	390	395	115	375	125
-	DOC7VX GW	390	370	90	350	100

* Indicative values depending on the float switch adjustment.

doc_docliv gw-2p50-en_a_td

ACCESSORIES

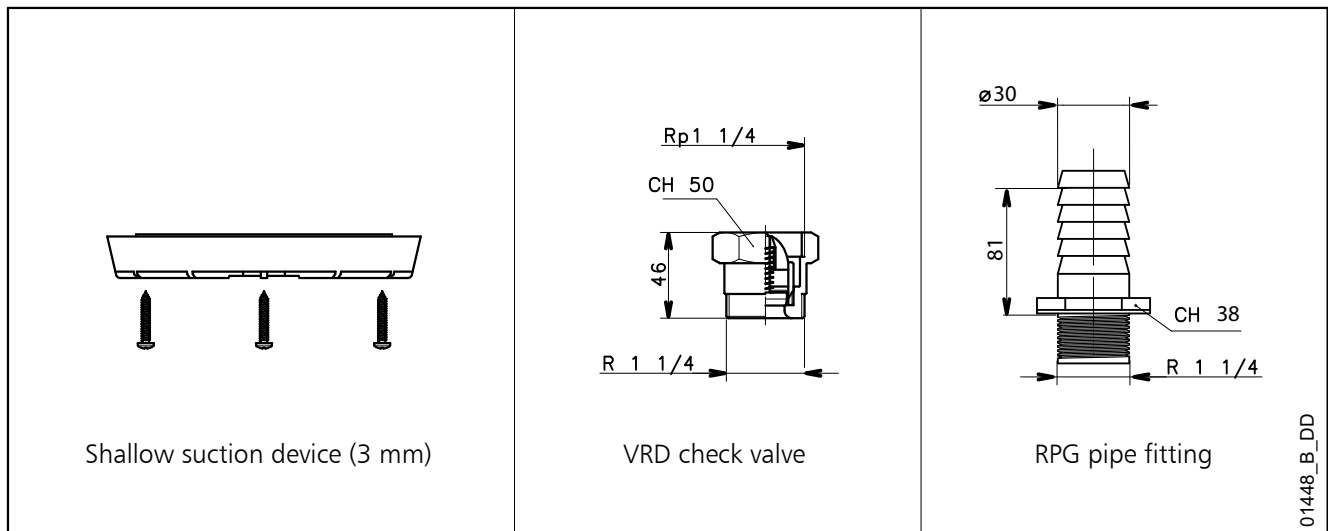

Shallow suction device (3 mm)

VRD check valve

RPG pipe fitting

Submersible Electric Pumps for drainage of clean and slightly dirty water

DIWA Series



Submersible pumps for clean and slightly dirty water manufactured in AISI 304 stainless steel. Head up to 20 metres, delivery up to 420 l/min (25,2 m³/h). Four basic models with 0,55 to 1,5 kW.

DRIVELUB SEAL SYSTEM.

Diffuser plate coated with polyurethane for the maximum resistance to abrasion.

APPLICATIONS

- Draining of cellars, garages, basements. Draining of construction sites.
- Emptying of tanks and reservoirs.
- Lawn and garden irrigation.
- Pumping of domestic wastewater washing machines, showers, sinks.
- Emptying of tanks in industrial and ecological applications.

SPECIFICATIONS

- **Maximum liquid temperature: 50°C.**
- **Open impeller.**
- Minimum level of pumped liquid: **25 mm.**
- **Maximum dimensions of suspended solids: 8 mm.**
- **Dry motor** cooled by the pumped liquid.
- **Power cord: H07RN-F, 10 m.**
 - single-phase: with plug.
 - three-phase: without plug.
- **Insulation class 155°C (F).**
- **IPX8 protection.**
- **Maximum immersion depth: 7 m.**
- **Versions:**
 - Single-phase: 220-240V, 50Hz 2 poles.
 - Three-phase: 220-240V, 50Hz 2 poles. 380-415V, 50Hz 2 poles.
- **Motor power:**
 - Single-phase: **0,55 to 1,1 kW.**
 - Three-phase: **0,55 to 1,5 kW.**
- **The single-phase versions** feature:
 - **pre-assembled float switch** for automatic pump operation.
 - **built-in capacitor.**
 - **thermal overload protection** to stop pump supply in case of overheating.
- SG versions (single-phase without float switch), GT versions (single-phase with pre-assembled tube float switch), 60 Hz single-phase and three-phase versions, versions with various power cord lengths and various plugs are available on request

DRIVELUB SEAL SYSTEM

- Watertight electric motor protected by multiple seal system with **oil chamber.**
- A **V-ring** and **silicon carbide mechanical seal** (extremely resistant to wear and abrasion), as well as a **lip seal** which is continuously lubricated by the **DRIVELUB system**, provide an extreme barrier against infiltration.

DIWA SERIES IDENTIFICATION CODE

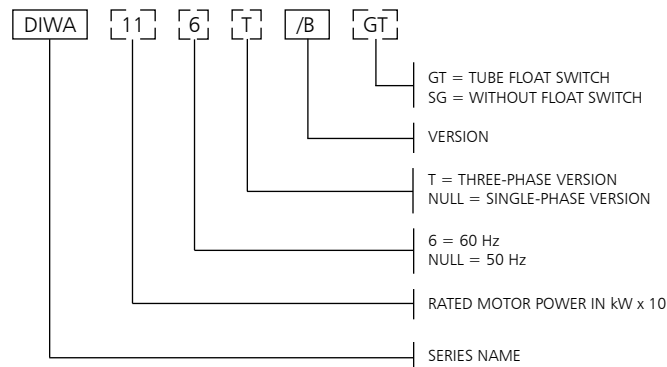

EXAMPLE : DIWA 11/B
DIWA Series Electric pump, rated motor power 1,1 kW,
50 Hz version, single-phase, /B version.

SINGLE-PHASE RATING PLATE

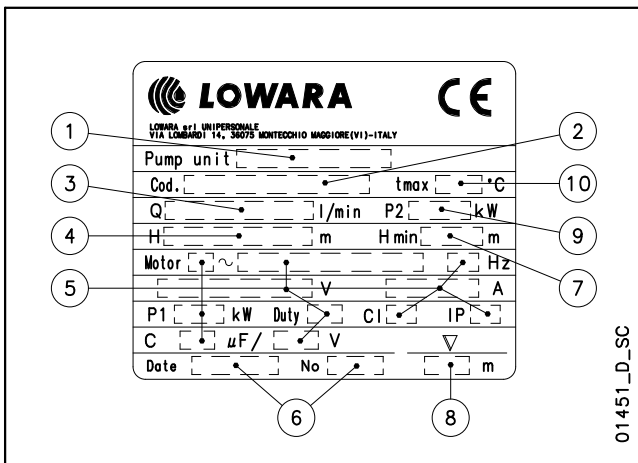

LEGEND

- 1 - Electric pump type
- 2 - Code
- 3 - Delivery range
- 4 - Head range
- 5 - Motor type
- 6 - Date of manufacture and serial number
- 7 - Minimum head
- 8 - Maximum immersion depth
- 9 - Rated output
- 10 - Maximum liquid temperature

THREE-PHASE RATING PLATE

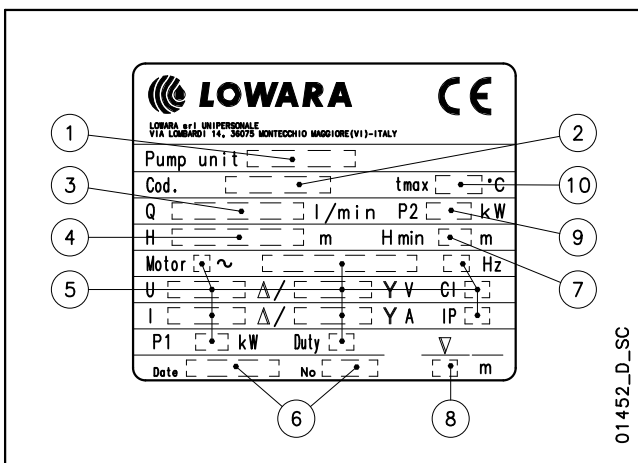

DIWA SERIES TABLE OF MATERIALS

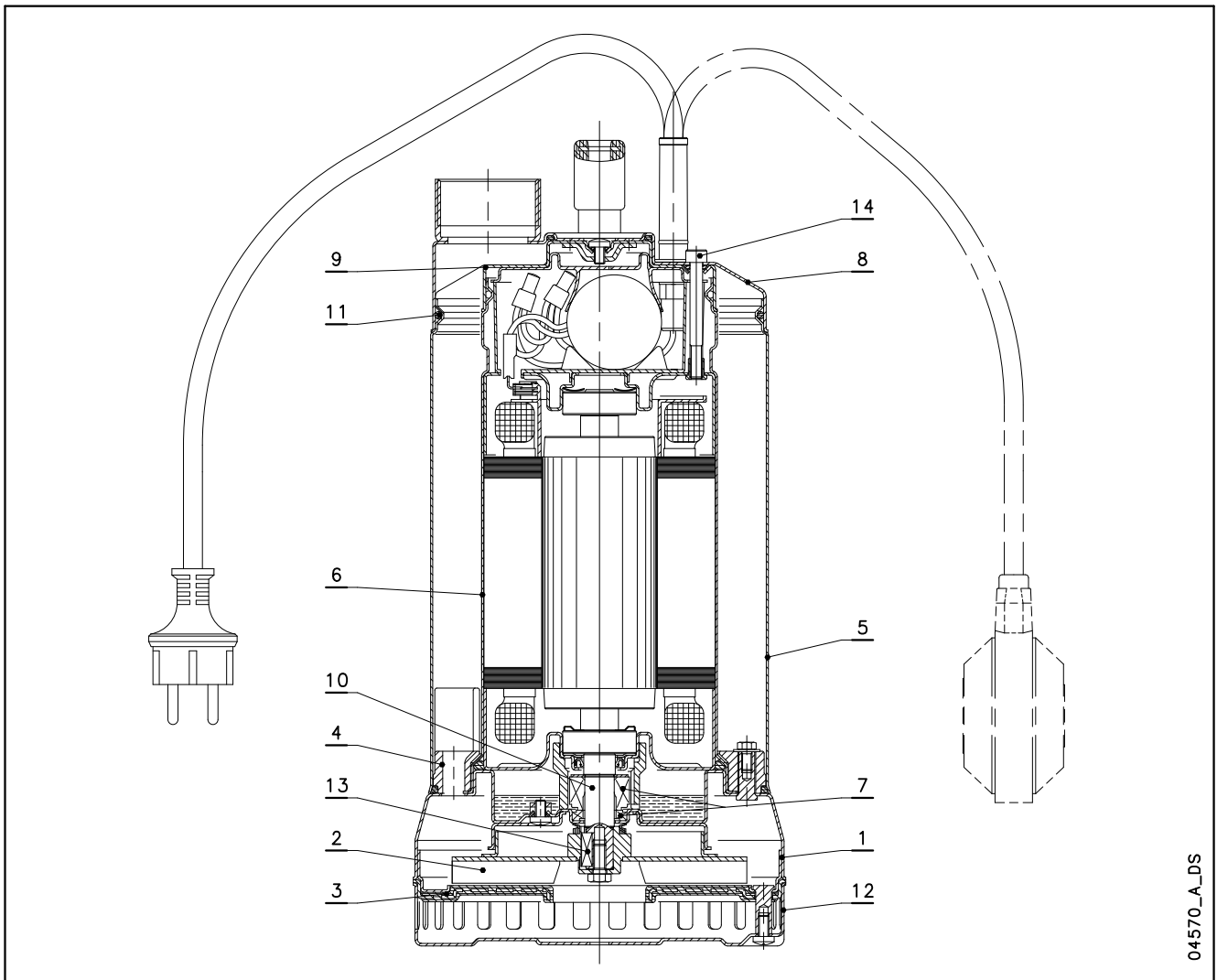

04570_A_DS

REF. N.	NAME	MATERIAL	REFERENCE STANDARDS	
			EUROPE	USA
1	Pump body	Stainless steel	EN 10088-1-X5CrNi18-10 (1.4301)	AISI 304
2	Impeller	Stainless steel	EN 10088-1-X5CrNi18-10 (1.4301)	AISI 304
3	Suction flange	Stainless steel	EN 10088-1-X5CrNi18-10 (1.4301)	AISI 304
		Thermoplastic polyurethane TPU		
4	Diffuser	PA 66 + 30 % GF		
5	Sleeve	Stainless steel	EN 10088-1-X5CrNi18-10 (1.4301)	AISI 304
6	Motor casing	Stainless steel	EN 10088-1-X5CrNi18-10 (1.4301)	AISI 304
7	Mechanical seal	Silicon carbide / Silicon carbide / NBR (standard version)		
8	Cover	Stainless steel	EN 10088-1-X5CrNi18-10 (1.4301)	AISI 304
9	Upper cover	Stainless steel	EN 10088-1-X5CrNi18-10 (1.4301)	AISI 304
10	Shaft end	Stainless steel	EN 10088-1-X5CrNi18-10 (1.4301)	AISI 304
11	Elastomers	NBR (standard version)		
12	Strainer	Stainless steel	EN 10088-1-X5CrNi18-10 (1.4301)	AISI 304
13	Key	Stainless steel	EN 10088-1-X5CrNiMo17-12-2 (1.4401)	AISI 316
14	Screws	Stainless steel	EN 10088-1-X5CrNi18-10 (1.4301)	AISI 304

diwa-en_b_tm

DIWA SERIES MECHANICAL SEAL

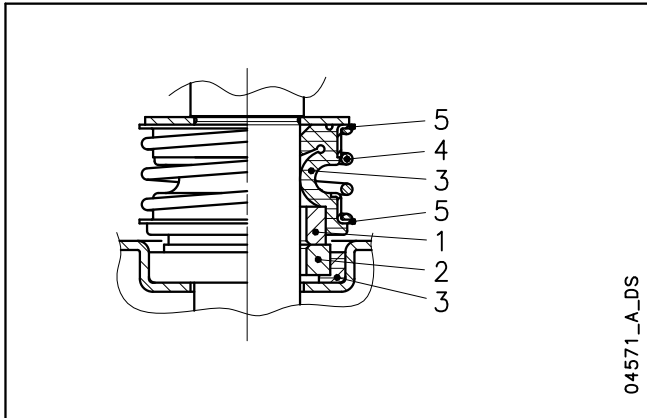

LIST OF MATERIALS

POSITION 1 - 2	POSITION 3	POSITION 4 - 5
Q1 : Silicon carbide	P : NBR	G : AISI 316
	V : FPM	

diwa_ten-mec-en_a_tm

SEAL TYPES

TYPE	POSITION					TEMPERATURE (°C)
	1 ROTATING ASSEMBLY	2 FIXED ASSEMBLY	3 ELASTOMERS	4 SPRINGS	5 OTHER COMPONENTS	
STANDARD MECHANICAL SEAL						
Q ₁ Q ₁ PGG	Q ₁	Q ₁	P	G	G	0 +50
OTHER MECHANICAL SEAL TYPES						
Q ₁ Q ₁ VGG	Q ₁	Q ₁	V	G	G	0 +50

diwa_tipi-ten-mec-en_b_tc

DIWA SERIES OPERATING CHARACTERISTICS AT 50 Hz

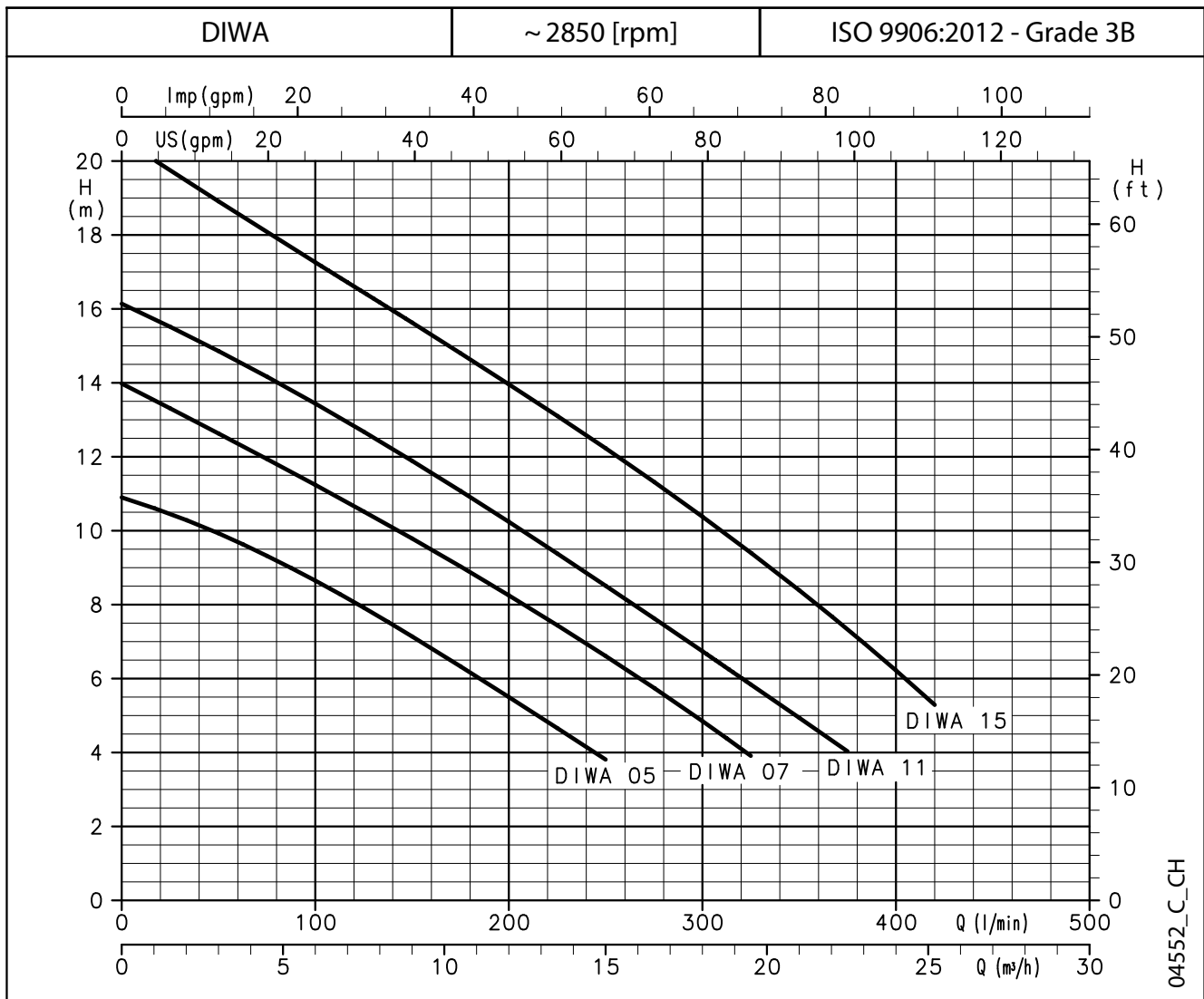

HYDRAULIC PERFORMANCE TABLE

PUMP TYPE	RATED POWER		Q = DELIVERY												
			l/min	0	100	125	150	175	200	225	250	300	325	375	420
			m ³ /h	0	6	7,5	9	10,5	12	13,5	15	18	19,5	22,5	25,2
	kW	HP	H = TOTAL HEAD METRES COLUMN OF WATER												
DIWA 05(T)	0,55	0,75	10,9	8,6	7,9	7,1	6,3	5,5	4,7	3,8					
DIWA 07(T)	0,75	1	14,0	11,2	10,5	9,8	9,0	8,3	7,4	6,6	4,8	3,9			
DIWA 11(T)	1,1	1,5	16,1	13,4	12,7	11,9	11,1	10,2	9,4	8,5	6,7	5,8	4,0		
DIWA 15T	1,5	2	20,6	17,3	16,4	15,6	14,8	14,0	13,1	12,2	10,4	9,4	7,3	5,3	

These performances are valid for liquids with density $\rho = 1,0 \text{ kg/dm}^3$ and kinematic viscosity $\nu = 1 \text{ mm}^2/\text{s}$.

diwa-2p50-en_a_th

ELECTRICAL DATA TABLE

PUMP TYPE	ABSORBED POWER*	ABSORBED CURRENT*	CAPACITOR
SINGLE-PHASE	kW	220-240 V A	$\mu\text{F} / 450 \text{ V}$
DIWA 05	0,79	3,92	16
DIWA 07	1,25	6,20	22
DIWA 11	1,53	6,83	30
-	-	-	-

PUMP TYPE	ABSORBED POWER*	ABSORBED CURRENT*	ABSORBED CURRENT*
THREE-PHASE	kW	220-240 V A	380-415 V A
DIWA 05T	0,72	2,56	1,48
DIWA 07T	1,2	4,26	2,46
DIWA 11T	1,44	4,64	2,68
DIWA 15T	2,05	6,74	3,89

*Maximum values within operating range

diwa-2p50-en_a_te

**DIWA SERIES
DIMENSIONS AND WEIGHTS**

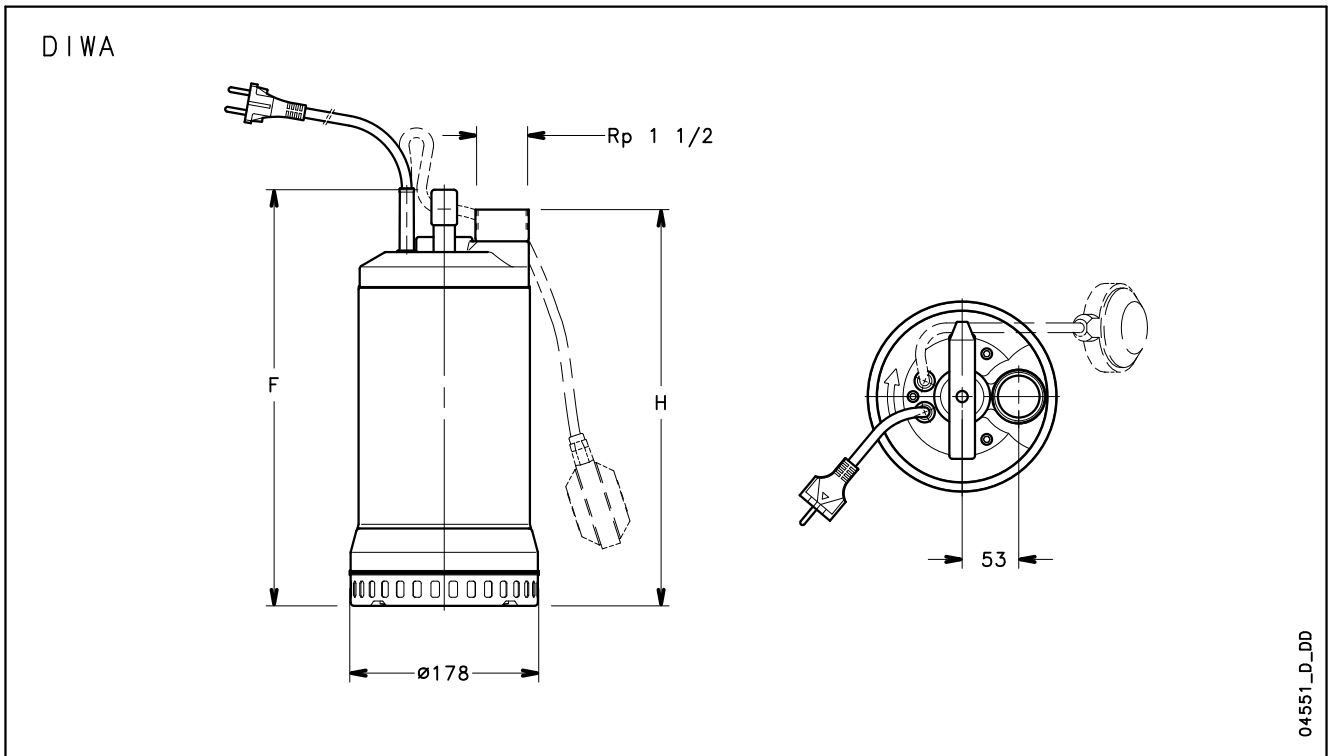

PUMP TYPE SINGLE-PHASE		DIMENSIONS (mm)		WEIGHT
		F	H	kg
DIWA05	DIWA05 GT	348	330	12
DIWA07	DIWA07 GT	393	375	14,3
DIWA11	DIWA11 GT	393	375	17
-	-	-	-	-

PUMP TYPE THREE-PHASE		DIMENSIONS (mm)		WEIGHT
		F	H	kg
DIWA05T		348	330	11
DIWA07T		363	345	13
DIWA11T		393	375	15
DIWA15T		393	375	16,5

diwa-2p50-en_b_td

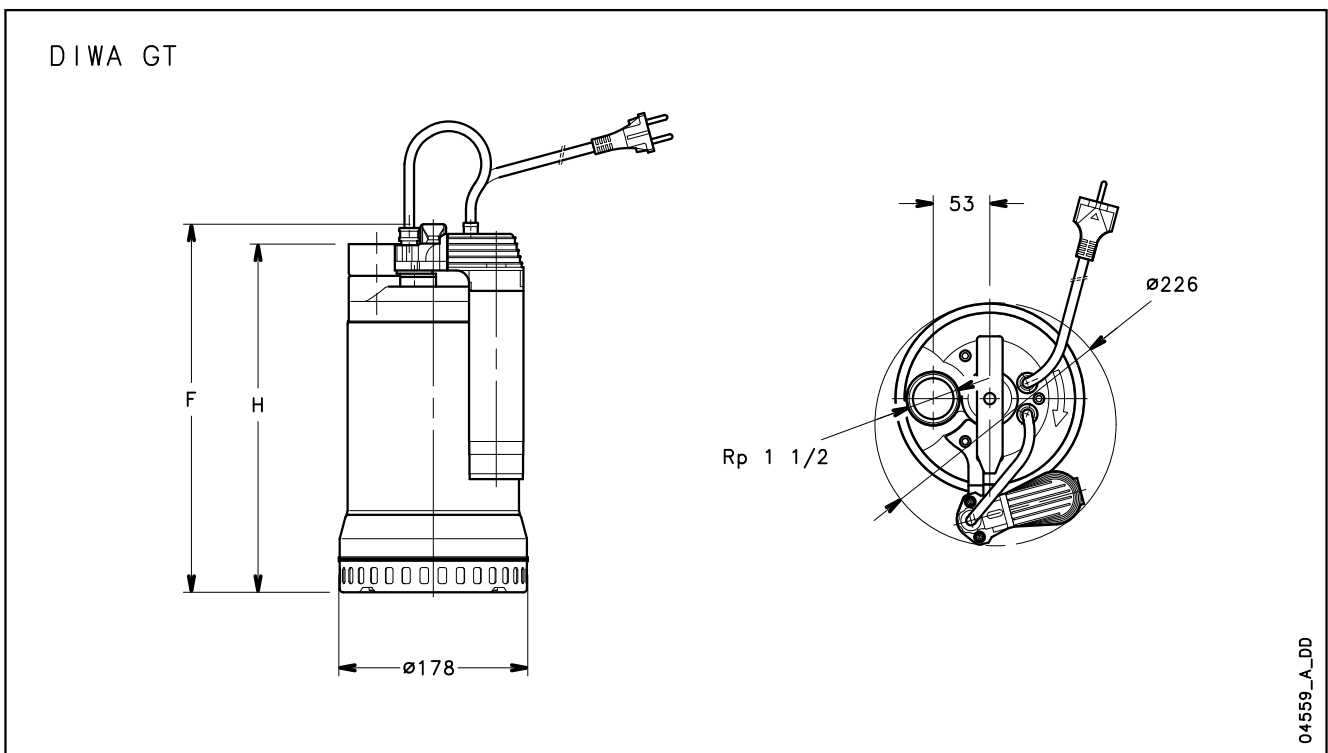

**DIWA SERIES
INSTALLATION EXAMPLES**

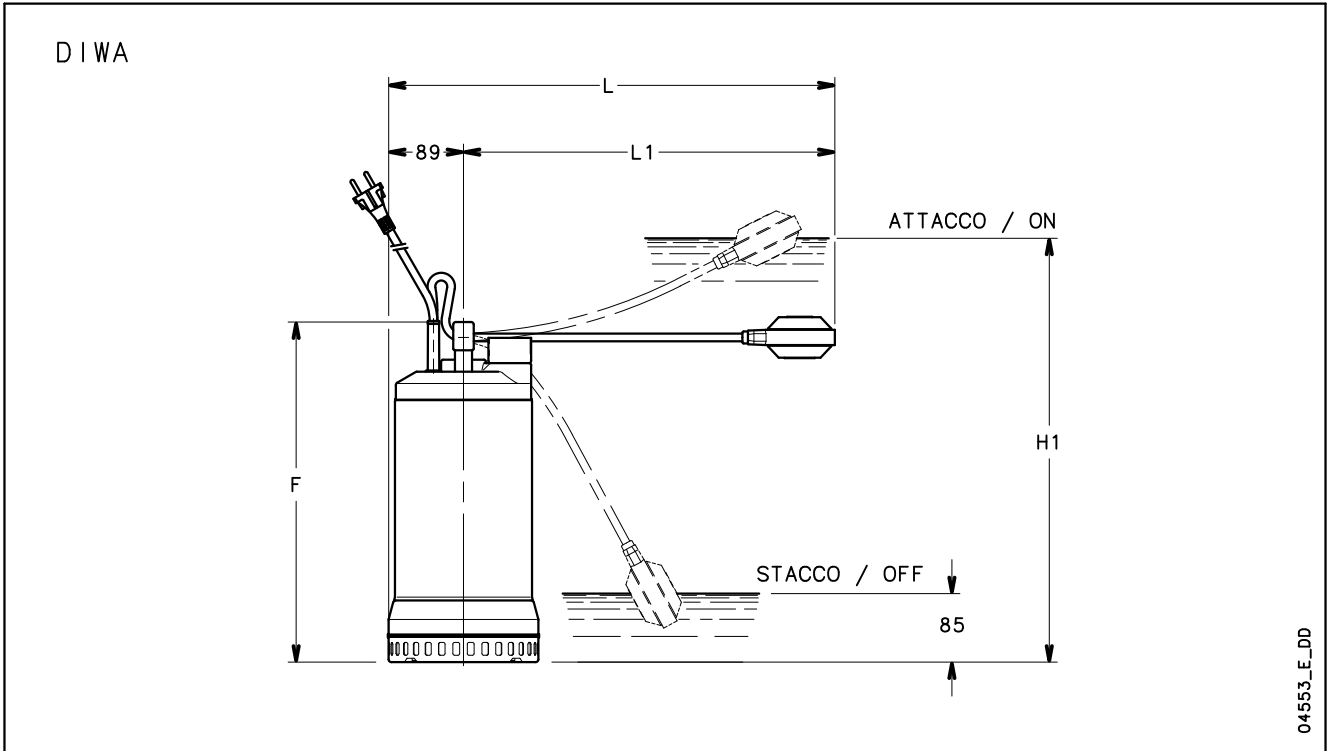

PUMP TYPE		DIMENSIONS (mm)				
		F	L	L1	H1	H2
DIWA05	DIWA05 GT	348	459	370	430	180
DIWA07	DIWA07 GT	393	504	415	490	180
DIWA11	DIWA11 GT	393	524	435	490	180

diwaliv-2p50-en_d_td

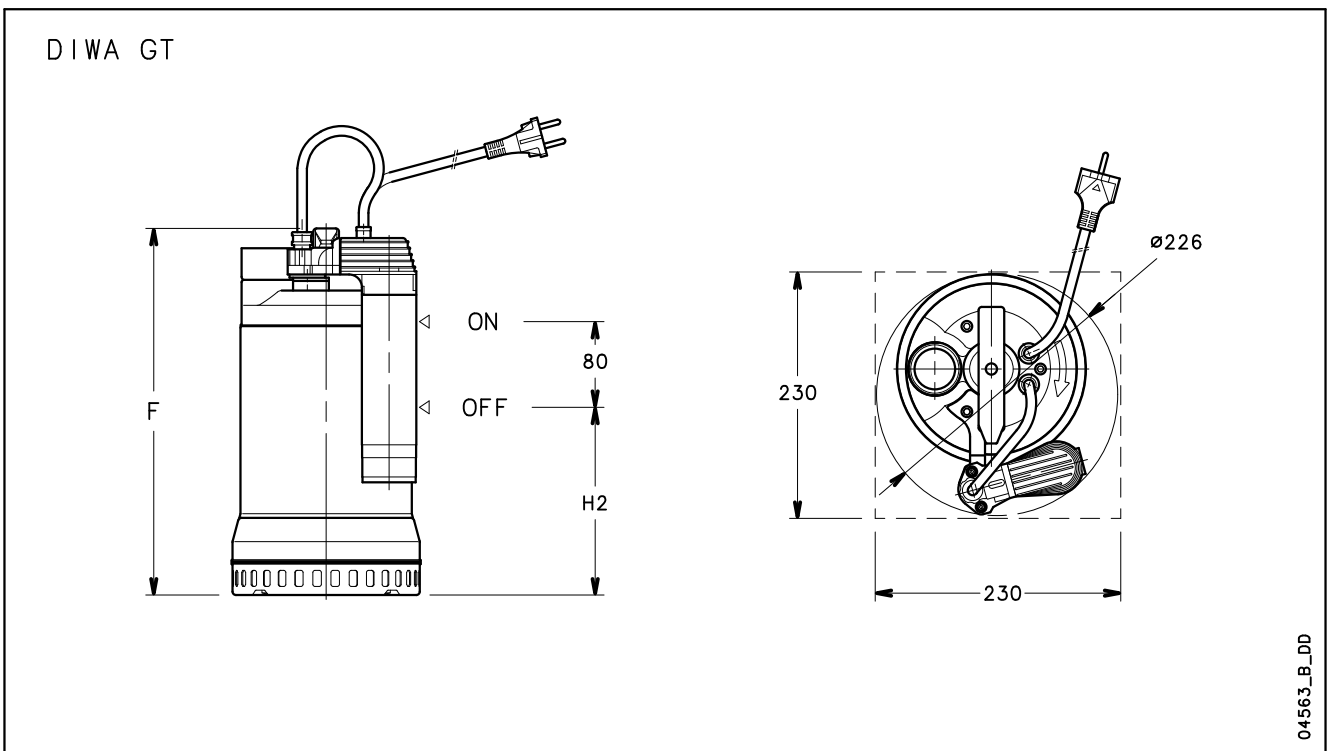

Submersible Electric Pumps for drainage of dirty water

DOMO Series



The DOMO series electric pumps are available with **twin-channel** or **vortex** impeller (DOMO VX). Designed to handle liquids with suspended solids up to 50 mm in diameter (35 mm for DOMO 7 and DOMO 7VX).

Four basic models with 0,55 to 1,5 kW.

DRIVELUB SEAL SYSTEM.

APPLICATIONS

- Pumping of effluent (VX model handles also suspended filaments).
- Emptying of septic tanks and residential sumps.
- Draining of flooded basements and garages.

SPECIFICATIONS

- **Maximum liquid temperature:** 35°C with fully submerged pump.
- **Dry motor.**
- **Power cord: H07RN-F**
 - single-phase: with plug.
 - three-phase: without plug.
- **Insulation class 155°C (F).**
- **IPX8 protection.**
- **Maximum immersion depth:** 5 m.
- **Versions:**
 - Single-phase: 220-240V, 50Hz 2 poles.
 - Three-phase: 220-240V, 50Hz 2 poles. 380-415V, 50Hz 2 poles.
- **Motor power:**
 - single-phase: **0,55 to 1,1 kW.**
 - three-phase: **0,55 to 1,5 kW.**
- **The single-phase versions feature:**
 - **pre-assembled float switch** for automatic pump operation.
 - **built-in capacitor.**
 - **thermal overload protection** to stop pump supply in case of overheating.
- The **DOMO 7** and **DOMO 7VX** models feature:
 - **Rp 1 1/2 threaded delivery port** (female gas).
 - handling of liquids with suspended **solids up to 35 mm** in diameter.
 - **fiberglass-reinforced technopolymer impeller** (DOMO S7 and DOMO S7VX models with stainless steel impeller are also available).
- The **DOMO 10-15-20** and **DOMO 10-15-20 VX** models feature:
 - **Rp 2" threaded delivery port** female gas (can be turned into a flanged version if an optional accessory is installed).
 - handling of liquids with suspended **solids up to 50 mm** in diameter.
 - **stainless steel twin-channel or vortex impeller.**
- **DRIVELUB SEAL SYSTEM**
 - Watertight electric motor protected by multiple seal system with **oil chamber.** A **V-ring** and **silicon carbide mechanical seal** (extremely resistant to wear and abrasion), as well as a **lip seal** which is continuously lubricated by the **DRIVELUB system**, provide an extreme barrier against infiltration.

Submersible Electric Pumps for drainage of dirty water equipped with grinder system

DOMO GRI Series



The DOMO GRI series electric pumps are equipped with an extremely efficient and highly reliable grinder system.

The grinder is able to macerate all the solids present in the sewage and to pass it through small discharge pipes (25 mm diameter). DOMO GRI is available in the 1,1 kW and 1,5 kW power.

DRIVELUB SEAL SYSTEM.

APPLICATIONS

- Pumping of sewage with suspended solids.
- Emptying of septic tanks and residential sumps.
- Draining of flooded areas.
- Pumping water from a pressurized sewer network.

SPECIFICATIONS

- **Maximum liquid temperature:** 35°C with fully submerged pump.
- **Dry motor.**
- **Power cord: H07RN-F**
 - single-phase: with plug.
 - three-phase: without plug.
- **Insulation class 155°C (F).**
 - **IPX8 protection.**
 - **Maximum immersion depth: 5 m.**
 - **Versions:**
 - Single-phase: 220-240V, 50Hz 2 poles.
 - Three-phase: 220-240V, 50Hz 2 poles. 380-415V, 50Hz 2 poles.
- **Motor power:**
 - **1,1 kW** single-phase and three-phase.
 - **1,5 kW** single-phase and three-phase.
- **The single-phase versions** feature:
 - **pre-assembled float switch** for automatic pump operation.
 - **built-in capacitor (only for 1,1 kW).**
 - **thermo-amperometric overload protection** to stop pump supply in case of overheating.
- **DOMO GRI** pumps feature:
 - **Rp 1" threaded delivery port (female gas)** for 1,1kW (11/A).
 - **Rp 1"1/4 threaded delivery port (female gas)** for 1,1kW (11/HF) and 1,5kW (15).
 - technopolymer PBT **Impeller.**
 - high resistance stainless steel **grinder.**

DRIVELUB SEAL SYSTEM

- Watertight electric motor protected by multiple seal system with **oil chamber**. A **V-ring** and **silicon carbide mechanical seal** (extremely resistant to wear and abrasion), as well as a **lip seal** which is continuously lubricated by the **DRIVELUB system**, provide an extreme barrier against infiltration.

DOMO SERIES IDENTIFICATION CODE

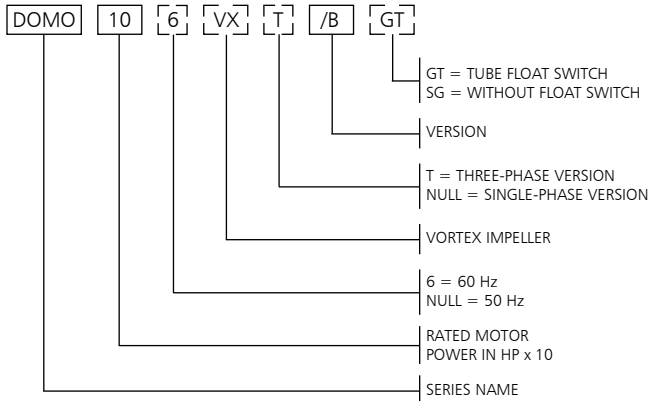

EXAMPLE : DOMO 10/B
 DOMO Series Electric pump, rated motor power 1 HP, 50 Hz version, single-phase, /B version.

DOMO GRI SERIES IDENTIFICATION CODE

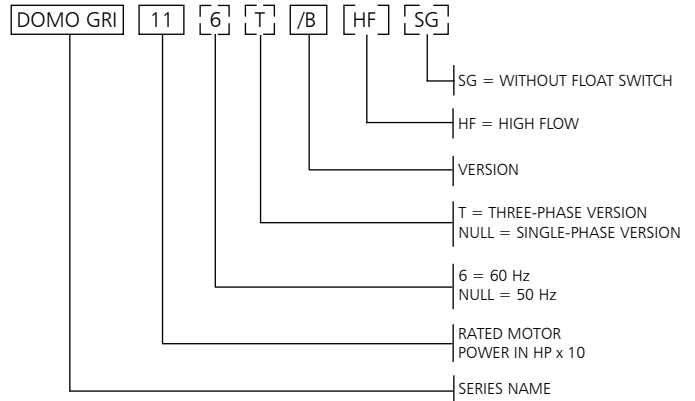

EXAMPLE : DOMO GRI 11
 DOMO GRI (grinder) Series Electric pump, rated motor power 1,1 kW, 50 Hz version, single-phase.

SINGLE-PHASE RATING PLATE

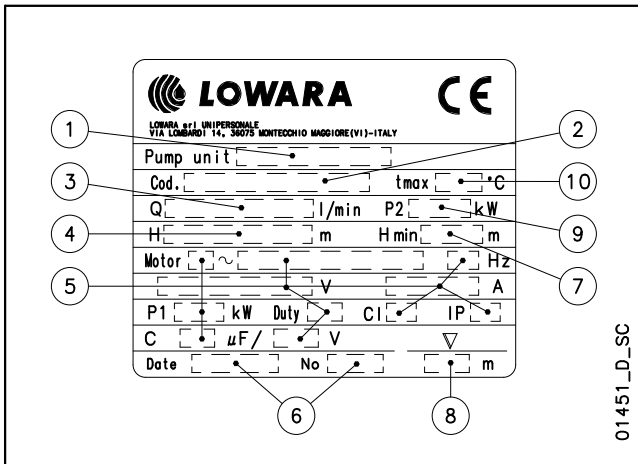

01451_D_SC

LEGEND

- 1 - Electric pump type
- 2 - Code
- 3 - Delivery range
- 4 - Head range
- 5 - Motor type
- 6 - Date of manufacture and serial number
- 7 - Minimum head
- 8 - Maximum immersion depth
- 9 - Rated output
- 10 - Maximum liquid temperature

THREE-PHASE RATING PLATE

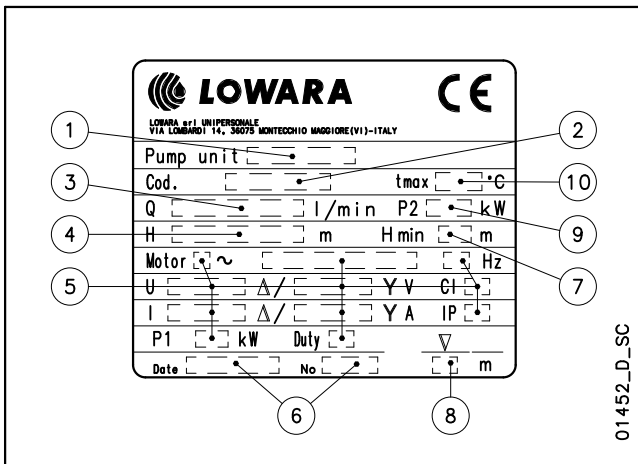

01452_D_SC

DOMO SERIES
TABLE OF MATERIALS

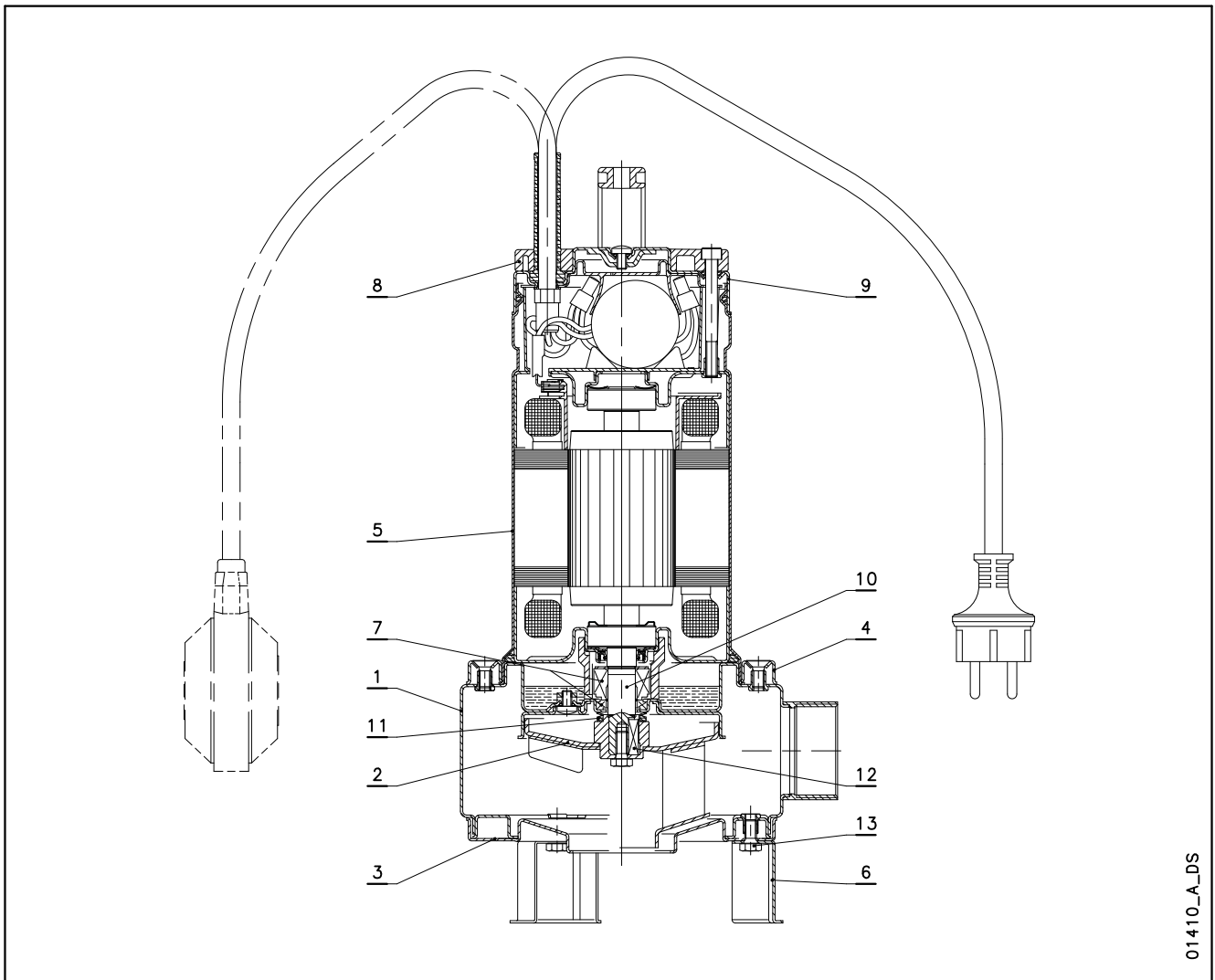

01410_A_DS

REF. N.	NAME	MATERIAL	REFERENCE STANDARDS	
			EUROPE	USA
1	Pump body	Stainless steel	EN 10088-1-X5CrNi18-10 (1.4301)	AISI 304
2	Impeller	PA 66 + 30 % GF		
		Stainless steel	EN 10088-1-X5CrNi18-10 (1.4301)	AISI 304
3	Suction flange	Stainless steel	EN 10088-1-X5CrNi18-10 (1.4301)	AISI 304
4	Fixing ring	Stainless steel	EN 10088-1-X5CrNi18-10 (1.4301)	AISI 304
5	Motor casing	Stainless steel	EN 10088-1-X5CrNi18-10 (1.4301)	AISI 304
6	Support foot	Stainless steel	EN 10088-1-X5CrNi18-10 (1.4301)	AISI 304
7	Mechanical seal	Silicon carbide / Silicon carbide / NBR (standard version)		
8	Handle	PA 66 + 30 % GF		
9	Upper cover	Stainless steel	EN 10088-1-X5CrNi18-10 (1.4301)	AISI 304
10	Shaft end	Stainless steel	EN 10088-1-X5CrNi18-10 (1.4301)	AISI 304
11	Elastomers	NBR (standard version)		
12	Key	Stainless steel	EN 10088-1-X5CrNiMo17-12-2 (1.4401)	AISI 316
13	Screws	Stainless steel	EN 10088-1-X5CrNi18-10 (1.4301)	AISI 304

domo-en_b_tm

DOMO GRI SERIES TABLE OF MATERIALS

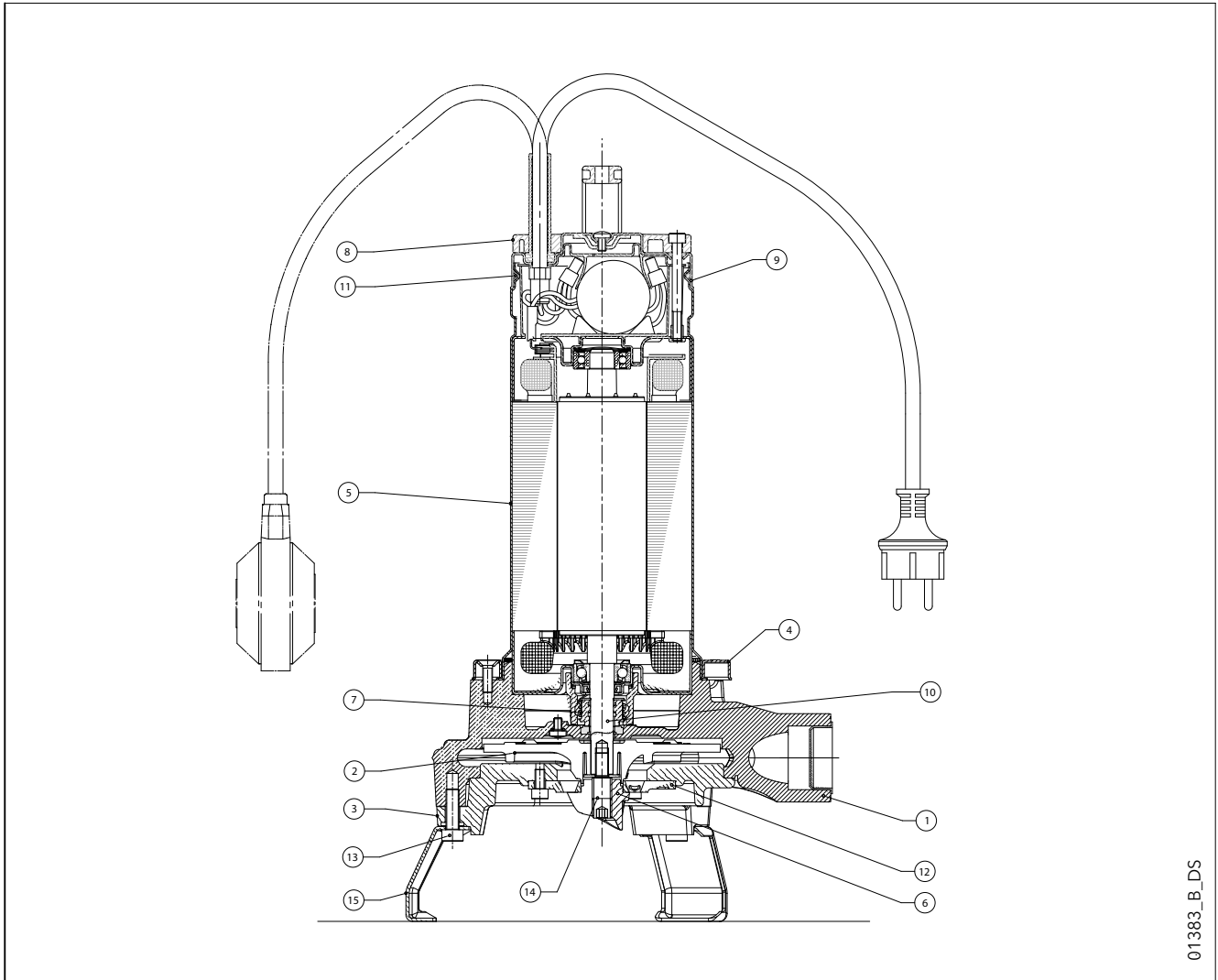

01383_B_DS

REF. N.	NAME	MATERIAL	REFERENCE STANDARDS	
			EUROPE	USA
1	Pump body	Cast iron	EN 1561-GJL-200 (JL1030)	ASTM Class 30
2	Impeller	PBT		
3	Suction cover	Cast iron	EN 1561-GJL-200 (JL103)	ASTM Class 30
4	Fixing ring	Stainless steel	EN 10088-1-X5CrNi18-10 (1.4301)	AISI 304
5	Motor casing	Stainless steel	EN 10088-1-X5CrNi18-10 (1.4301)	AISI 304
6	Cutter wheel	Stainless steel	X95CrMoV17 (DIN 1.4535)	-
7	Mechanical seal	Silicon carbide / Silicon carbide / NBR (standard version)		
8	Handle	PA 66 + 30 % GF		
9	Upper cover	Stainless steel	EN 10088-1-X5CrNi18-10 (1.4301)	AISI 304
10	Shaft end	Stainless steel	EN 10088-1-X5CrNi18-10 (1.4301)	AISI 304
11	Elastomers	NBR (standard version)		
12	Cutter ring	Stainless steel	X95CrMoV17 (DIN 1.4535)	-
13	Screws	Stainless steel	EN 10088-1-X5CrNi18-10 (1.4301)	AISI 304
14	Impeller fixing screw + wheel	Stainless steel	EN 10088-1-X17CrNi16-2 (1.4057)	AISI 431
15	Support foot	Stainless steel	EN 10088-1-X5CrNi18-10 (1.4301)	AISI 304

domo-gri-en_d_tm

DOMO SERIES - DOMO GRI MECHANICAL SEAL

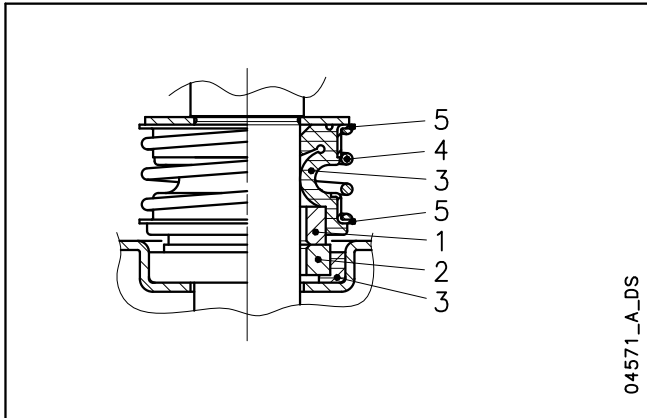

LIST OF MATERIALS

POSITION 1 - 2	POSITION 3	POSITION 4 - 5
Q1 : Silicon carbide	P : NBR	G : AISI 316
	V : FPM	

diwa_ten-mec-en_a_tm

SEAL TYPES

TYPE	POSITION					TEMPERATURE (°C)
	1 ROTATING ASSEMBLY	2 FIXED ASSEMBLY	3 ELASTOMERS	4 SPRINGS	5 OTHER COMPONENTS	
STANDARD MECHANICAL SEAL						
Q ₁ Q ₁ PGG	Q ₁	Q ₁	P	G	G	0 +35
OTHER MECHANICAL SEAL TYPES						
Q ₁ Q ₁ VGG	Q ₁	Q ₁	V	G	G	0 +35

domo_tipi-ten-mec-en_b_tc

DOMO SERIES OPERATING CHARACTERISTICS AT 50 Hz

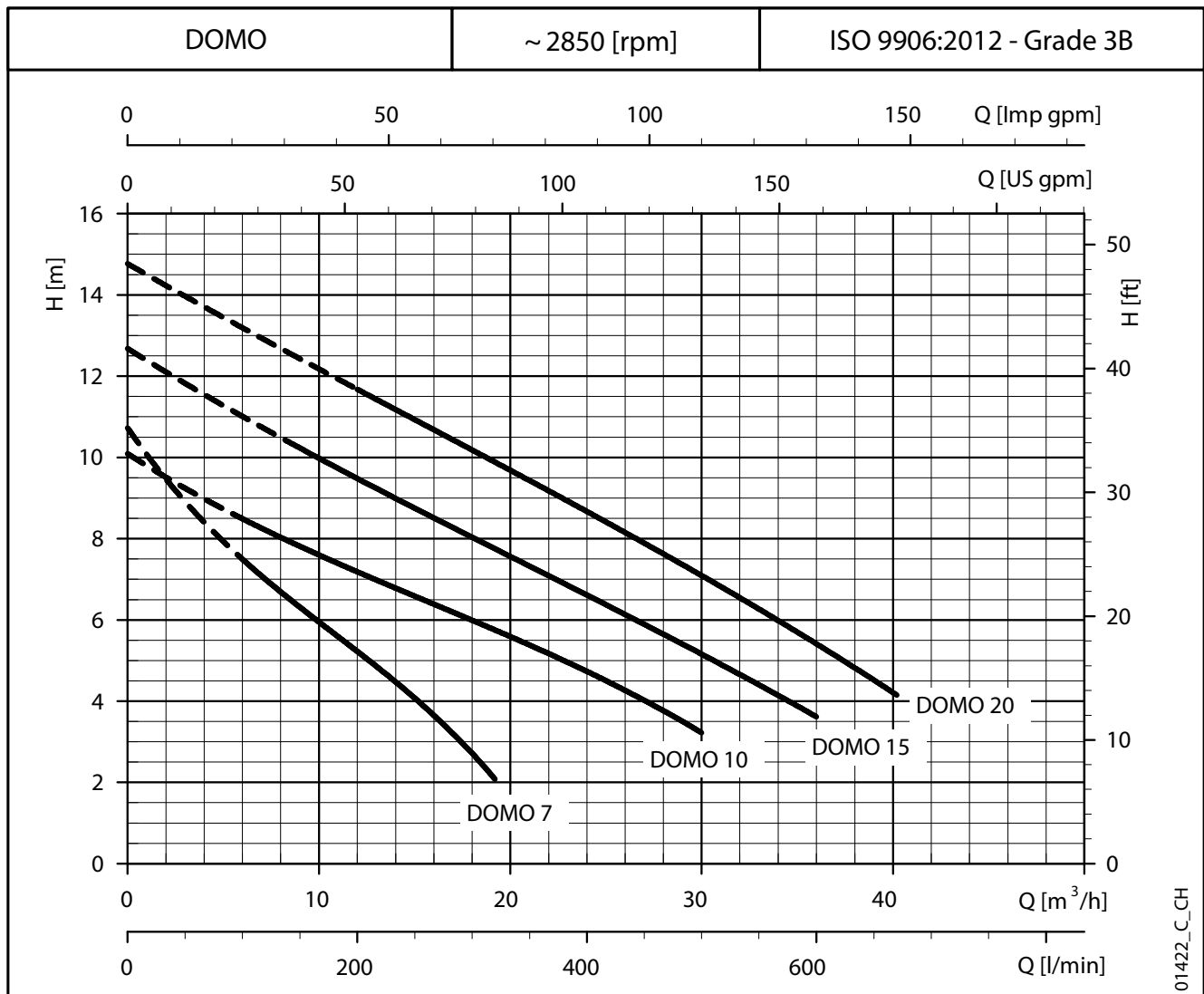

HYDRAULIC PERFORMANCE TABLE

PUMP TYPE	RATED POWER		Q = DELIVERY											
			l/min	0	100	150	200	250	300	320	400	500	600	670
			m ³ /h	0	6	9	12	15	18	19,2	24	30	36	40,2
H = TOTAL HEAD METRES COLUMN OF WATER														
DOMO 7(T) - S7(T)	0,55	0,75	10,7	7,5	6,3	5,2	4,1	2,7	2,1					
DOMO 10(T)	0,75	1	10,1	8,5	7,8	7,2	6,6	6,0	5,8	4,7	3,2			
DOMO 15(T)	1,1	1,5	12,7	11,0	10,2	9,5	8,8	8,0	7,8	6,6	5,2	3,6		
DOMO 20T	1,5	2	14,8	13,2	12,4	11,7	10,9	10,2	9,9	8,7	7,1	5,4	4,2	

These performances are valid for liquids with density $\rho = 1,0 \text{ kg/dm}^3$ and kinematic viscosity $\nu = 1 \text{ mm}^2/\text{s}$.

domo-2p50-en_b_th

ELECTRICAL DATA TABLE

PUMP TYPE	ABSORBED POWER*	ABSORBED CURRENT*	CAPACITOR
SINGLE-PHASE	kW	220-240 V A	$\mu\text{F} / 450 \text{ V}$
DOMO 7 - (S7)	0,8 (0,76)	3,94 (3,83)	16
DOMO 10	1,14	5,84	22
DOMO 15	1,58	7,02	30
-	-	-	-

PUMP TYPE	ABSORBED POWER*	ABSORBED CURRENT*	ABSORBED CURRENT*
THREE-PHASE	kW	220-240 V A	380-415 V A
DOMO 7T - (S7T)	0,73 (0,68)	2,58	1,49
DOMO 10T	1,09	4,09	2,36
DOMO 15T	1,49	4,73	2,73
DOMO 20T	1,96	6,6	3,81

*Maximum values within operating range

domo-2p50-en_b_te

DOMO VX SERIES OPERATING CHARACTERISTICS AT 50 Hz

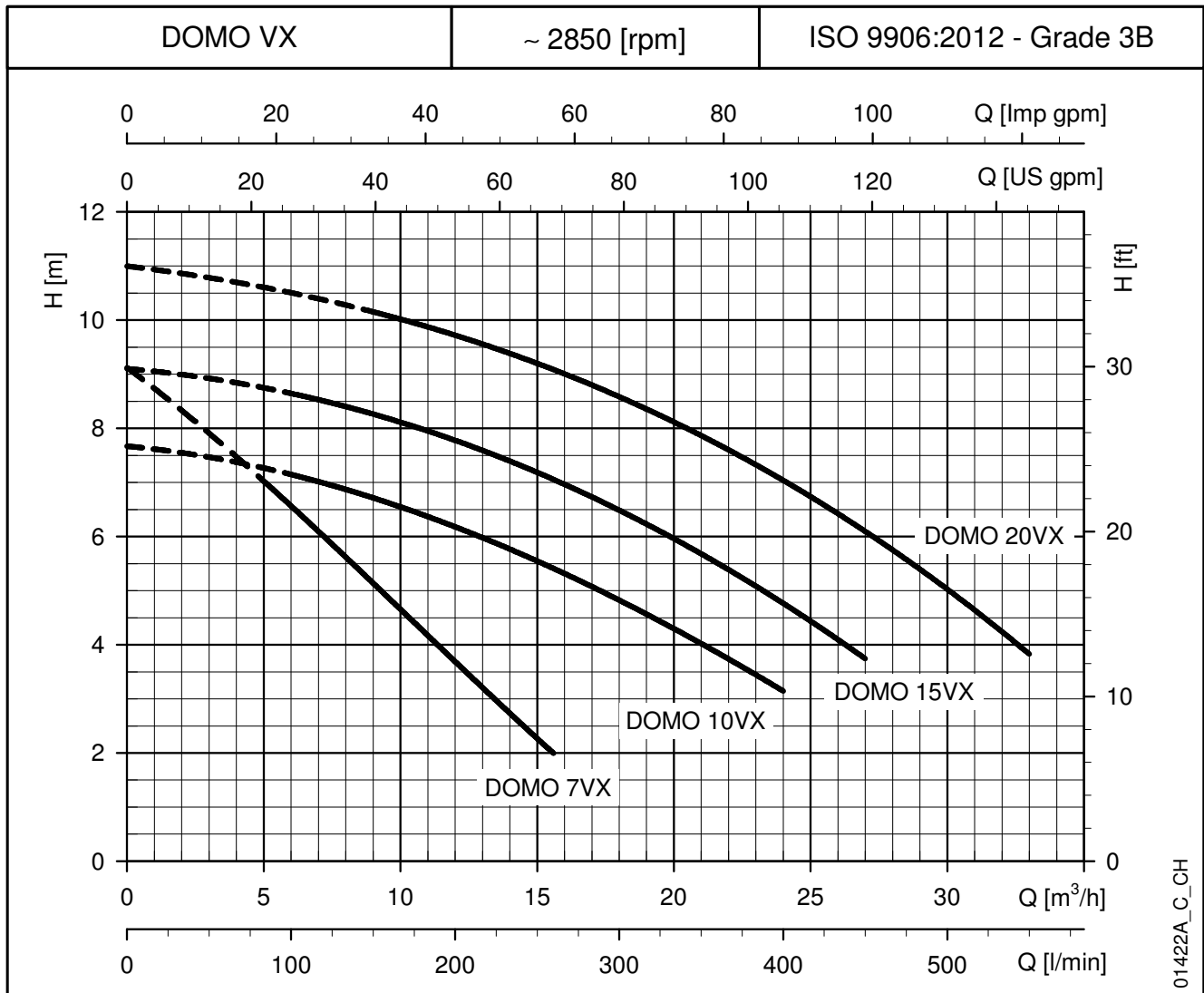

HYDRAULIC PERFORMANCE TABLE

PUMP TYPE	RATED POWER		Q = DELIVERY												
			H = TOTAL HEAD METRES COLUMN OF WATER												
			l/min	0	80	100	150	175	200	225	260	300	400	450	550
	kW	HP	m ³ /h	0	4,8	6	9	10,5	12	13,5	15,6	18	24	27	33
DOMO 7VX(T) - S7VX(T)	0,55	0,75	9,1	7,1	6,6	5,1	4,4	3,7	3,0	2,0					
DOMO 10VX(T)	0,75	1	7,7	7,3	7,1	6,7	6,5	6,2	5,9	5,4	4,8	3,1			
DOMO 15VX(T)	1,1	1,5	9,1	8,8	8,6	8,3	8,0	7,8	7,5	7,1	6,5	4,8	3,7		
DOMO 20VXT	1,5	2	11,0	10,6	10,5	10,2	9,9	9,7	9,5	9,1	8,6	7,0	6,1	3,8	

These performances are valid for liquids with density $\rho = 1,0 \text{ kg/dm}^3$ and kinematic viscosity $\nu = 1 \text{ mm}^2/\text{s}$.

domovx-2p50-en_b_th

ELECTRICAL DATA TABLE

PUMP TYPE	ABSORBED POWER*		CAPACITOR	PUMP TYPE	ABSORBED POWER*		ABSORBED CURRENT*
	SINGLE-PHASE				THREE-PHASE		
	kW	A	$\mu\text{F} / 450 \text{ V}$		kW	A	A
DOMO 7VX - (S7VX)	0,79 (0,83)	3,91 (4,03)	16	DOMO 7VXT - (S7VXT)	0,71 (0,76)	2,56 (2,63)	1,48 (1,52)
DOMO 10VX	1,15	5,88	22	DOMO 10VXT	1,10	4,09	2,36
DOMO 15VX	1,36	6,11	30	DOMO 15VXT	1,26	4,31	2,49
-	-	-	-	DOMO 20VXT	1,74	6,22	3,59

*Maximum values within operating range

domovx-2p50-en_b_te

DOMO GRI SERIES OPERATING CHARACTERISTICS AT 50 Hz

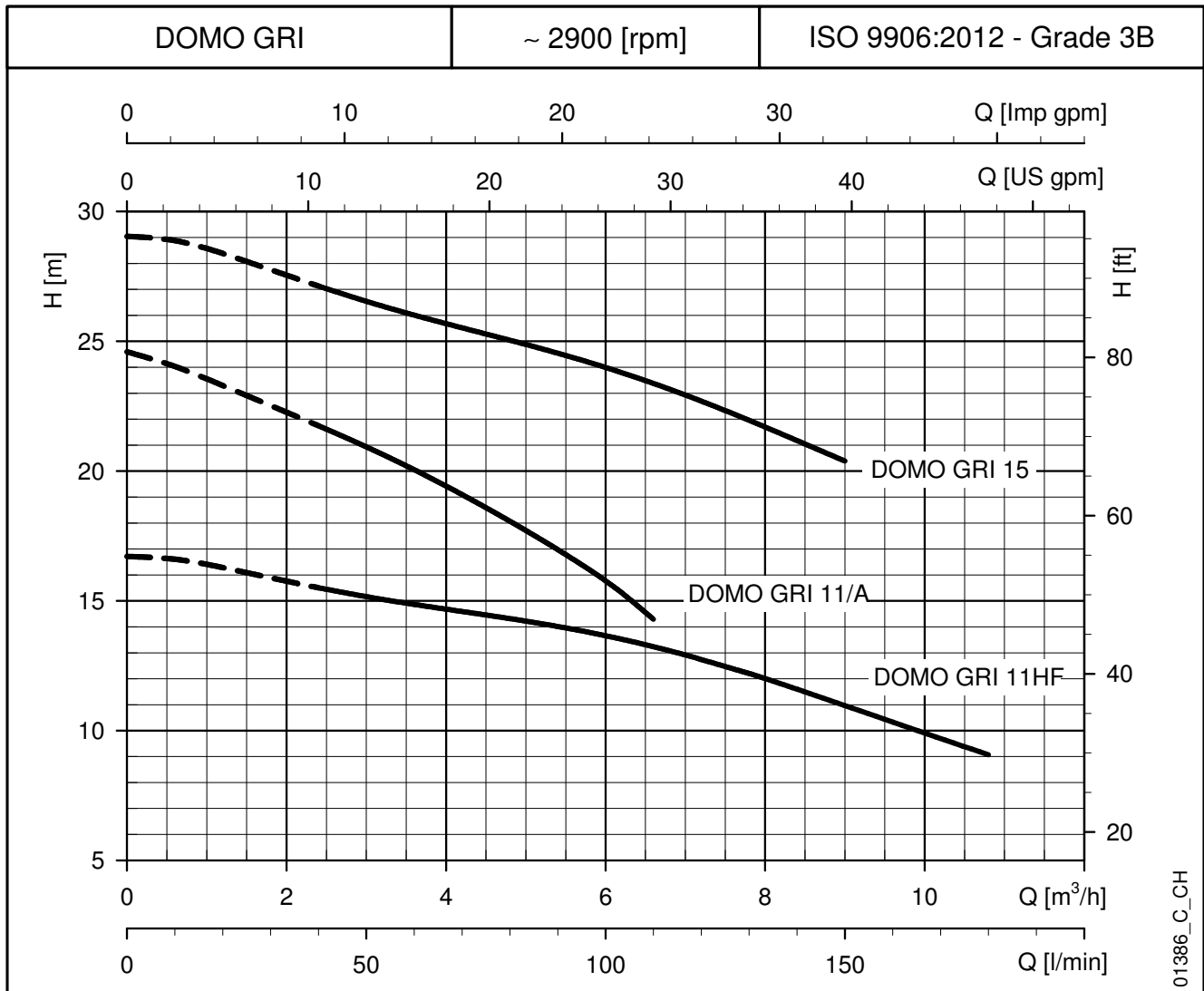

HYDRAULIC PERFORMANCE TABLE

PUMP TYPE	RATED POWER		Q = DELIVERY										
			1/s	0,7	0,9	1,1	1,7	1,9	2,2	2,4	2,6	2,8	3,0
		m³/h	2,4	3,2	3,9	6,2	7,0	7,7	8,5	9,3	10,0	10,8	
		H = TOTAL HEAD METRES COLUMN OF WATER											
	kW	HP											
DOMO GRI 11/A (SG)	1,1	1,5	24,6	21,7	20,7	19,5	15,3						
DOMO GRI 11T/A	1,1	1,5	24,6	21,7	20,7	19,5	15,3						
DOMO GRI 11 HF (SG)	1,1	1,5	16,7	15,5	15,1	14,7	13,5	12,9	12,3	11,5	10,7	9,9	9,1
DOMO GRI 11T HF	1,1	1,5	16,7	15,5	15,1	14,7	13,5	12,9	12,3	11,5	10,7	9,9	9,1
DOMO GRI 15 (SG)	1,5	2	29,0	27,1	26,4	25,7	23,8	23,0	22,0	21,0			
DOMO GRI 15T	1,5	2	29,0	27,1	26,4	25,7	23,8	23,0	22,0	21,0			

These performances are valid for liquids with density $\rho = 1,0 \text{ kg/dm}^3$ and kinematic viscosity $\nu = 1 \text{ mm}^2/\text{s}$.

domo-gri-2p50-en_c_th

ELECTRICAL DATA TABLE

PUMP TYPE	ABSORBED POWER*	ABSORBED CURRENT*	CAPACITOR	PUMP TYPE	ABSORBED POWER*	ABSORBED CURRENT*	ABSORBED CURRENT*
	SINGLE-PHASE				THREE-PHASE		
	kW	220-240 V A	$\mu\text{F} / 450 \text{ V}$		kW	220-240 V A	380-415 V A
DOMO GRI 11/A (SG)	1,20	5,41	30	DOMO GRI 11T/A	1,11	3,85	2,22
DOMO GRI 11HF	1,09	4,97	30	DOMO GRI 11T HF	0,96	3,81	2,20
DOMO GRI 15 (SG)	1,93	8,44	40	DOMO GRI 15T	1,57	5,94	3,43

* Maximum value in specified range

domo-gri-2p50-en_d_te

DOMO SERIES DIMENSIONS AND WEIGHTS

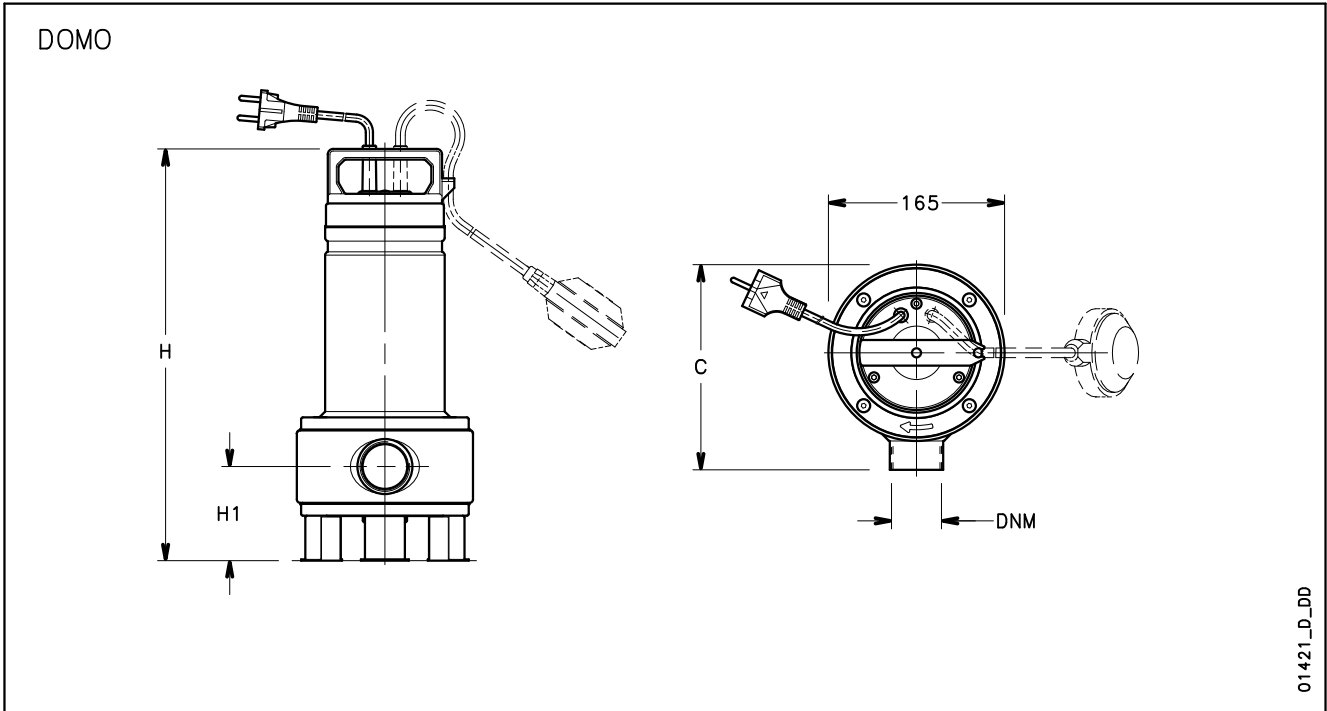

PUMP TYPE SINGLE-PHASE		DIMENSIONS (mm)			DNM	WEIGHT kg
		H	H1	C		
DOMO 7	DOMO 7 GT	391	88	193	Rp1½	10,2
DOMO 7VX	DOMO 7VX GT					
DOMO10	DOMO10 GT	468	111,5	198	Rp2	13,6
DOMO10VX	DOMO10VX GT					
DOMO15	DOMO15 GT	468	111,5	198	Rp2	15,3
DOMO15VX	DOMO15VX GT					
-	-	-	-	-	-	-

PUMP TYPE THREE-PHASE		DIMENSIONS (mm)			DNM	WEIGHT kg
		H	H1	C		
DOMO 7T	DOMO 7VXT	391	88	193	Rp1½	8,9
DOMO10T	DOMO10VXT					
DOMO15T	DOMO15VXT	468	111,5	198	Rp2	13,6
DOMO20T	DOMO20VXT					

domo-2p50-en_c_dd

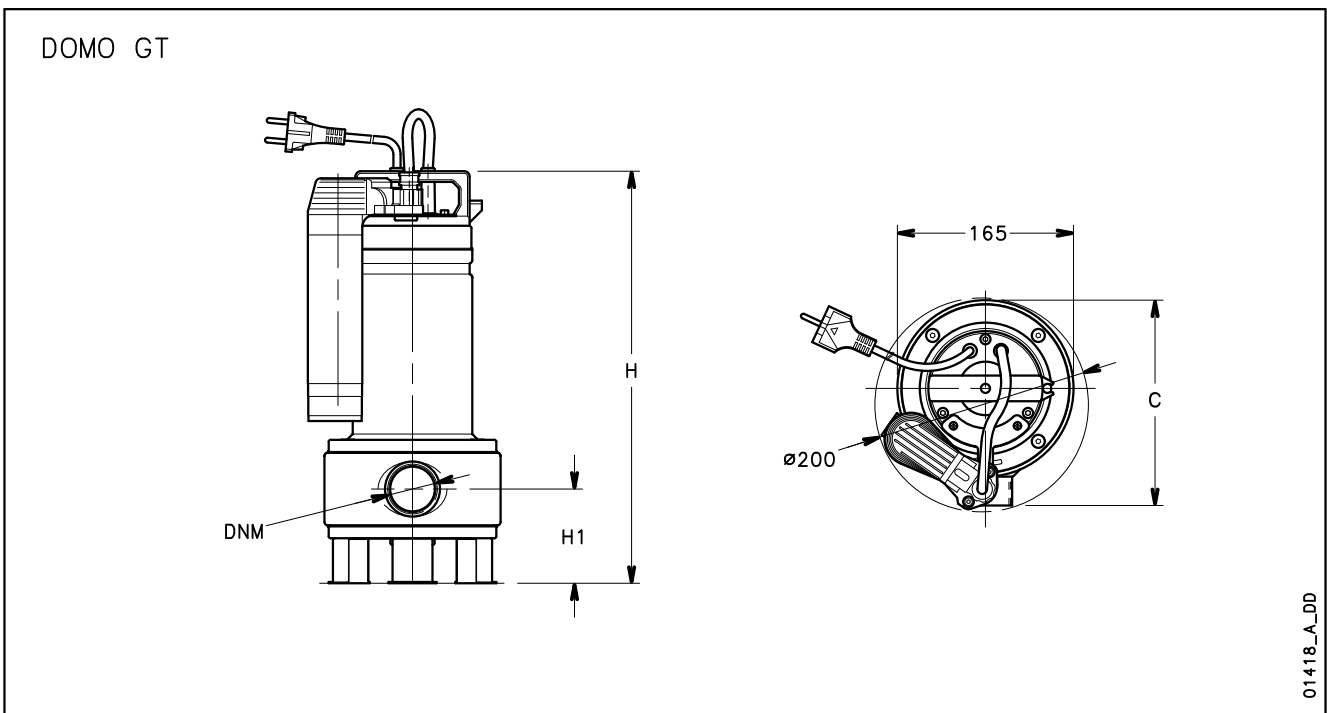

DOMO - DOMO GRI SERIES INSTALLATION EXAMPLES

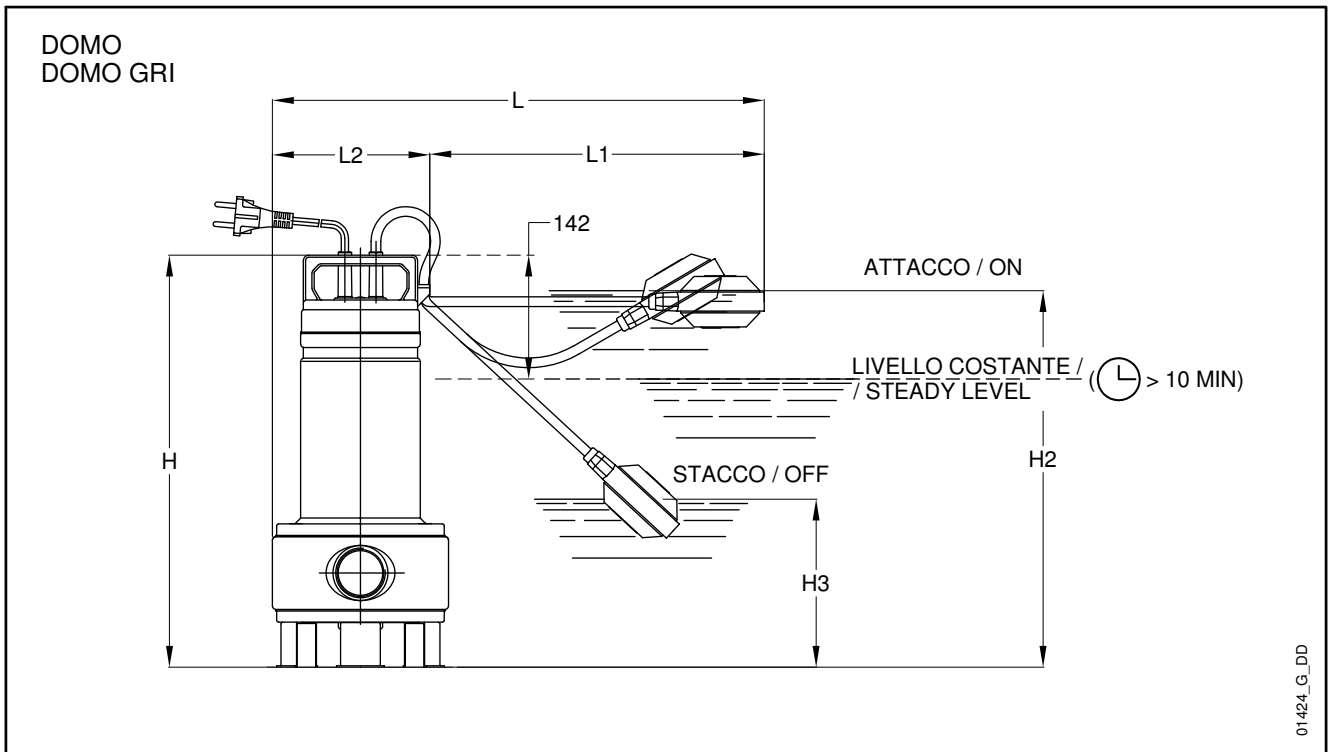

POMPA TIPO		DIMENSIONI (mm)						
		H	H2	H3	L	L1	L2	A
DOMO 7 - DOMO 7 GT	DOMO 7VX - DOMO 7VX GT	391	375	155	420	275	145	225
DOMO10 - DOMO10 GT	DOMO10VX - DOMO10VX GT	468	420	155	495	350	145	255
DOMO15 - DOMO15 GT	DOMO15VX - DOMO15VX GT	468	420	155	495	350	145	255
DOMO GRI 11(T)/A (SG)	DOMO GRI 15T	442	394	129	535	350	185	-
DOMO GRI 11(T)HF (SG)	-	444	396	131	535	350	185	-
DOMO GRI 15 (SG)	-	462	414	149	535	350	185	-

domoliv-2p50_f_td

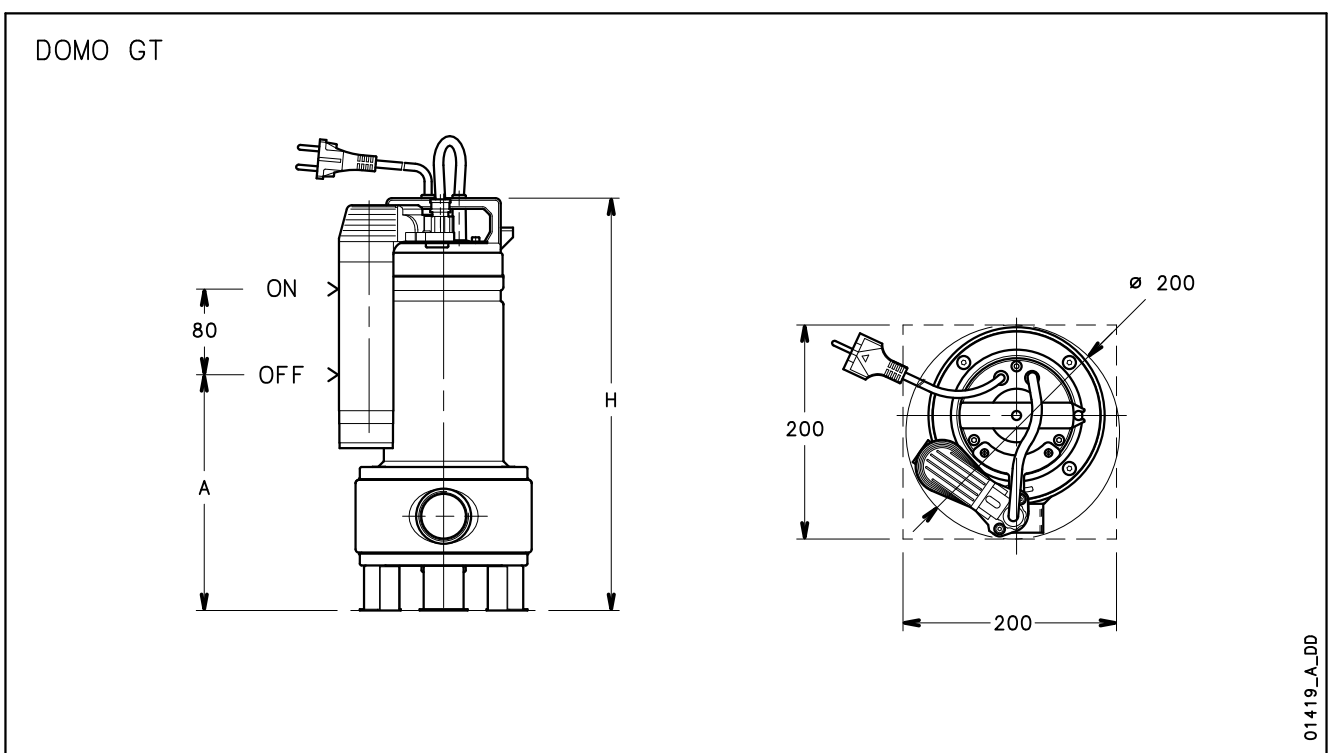

DOMO SERIES INSTALLATION WITH SD LOWERING DEVICE

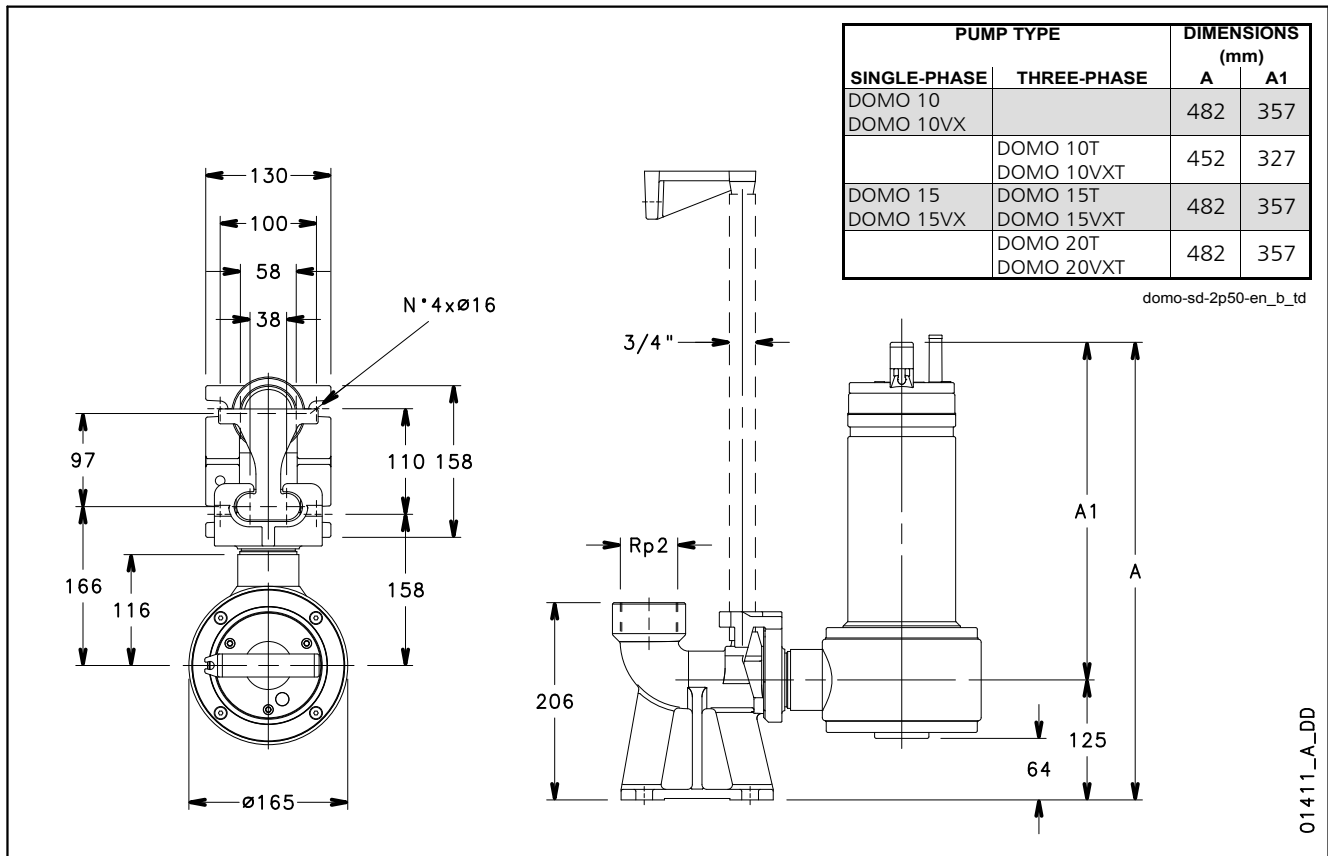

DOMO GRI SERIES DIMENSIONS AND WEIGHTS

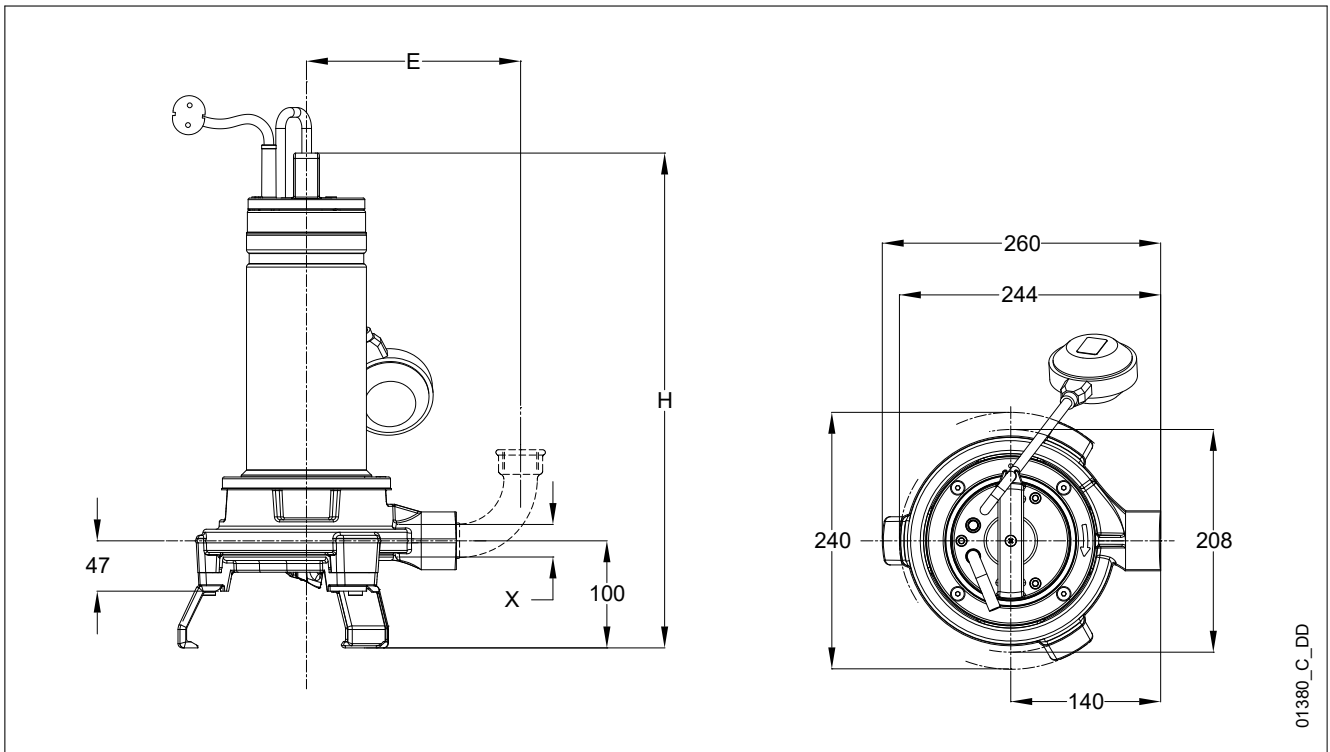

01380_C_DD

PUMP TYPE	DIMENSIONS (mm)			WEIGHT (kg)
	E	H	X	
DOMO GRI 11/A (SG)	200	442	Rp 1"	20,8 (20,6)
DOMO GRI 11T/A	200	442	Rp 1"	20,1
DOMO GRI 11HF (SG)	220	444	Rp 1" 1/4	20,8 (20,6)
DOMO GRI 11T HF	220	444	Rp 1" 1/4	20,1
DOMO GRI 15 (SG)	220	462	Rp 1" 1/4	23 (22,8)
DOMO GRI 15T	220	442	Rp 1" 1/4	22,3

domo-gri-en_d_td

INSTALLATION WITH SD LOWERING DEVICE

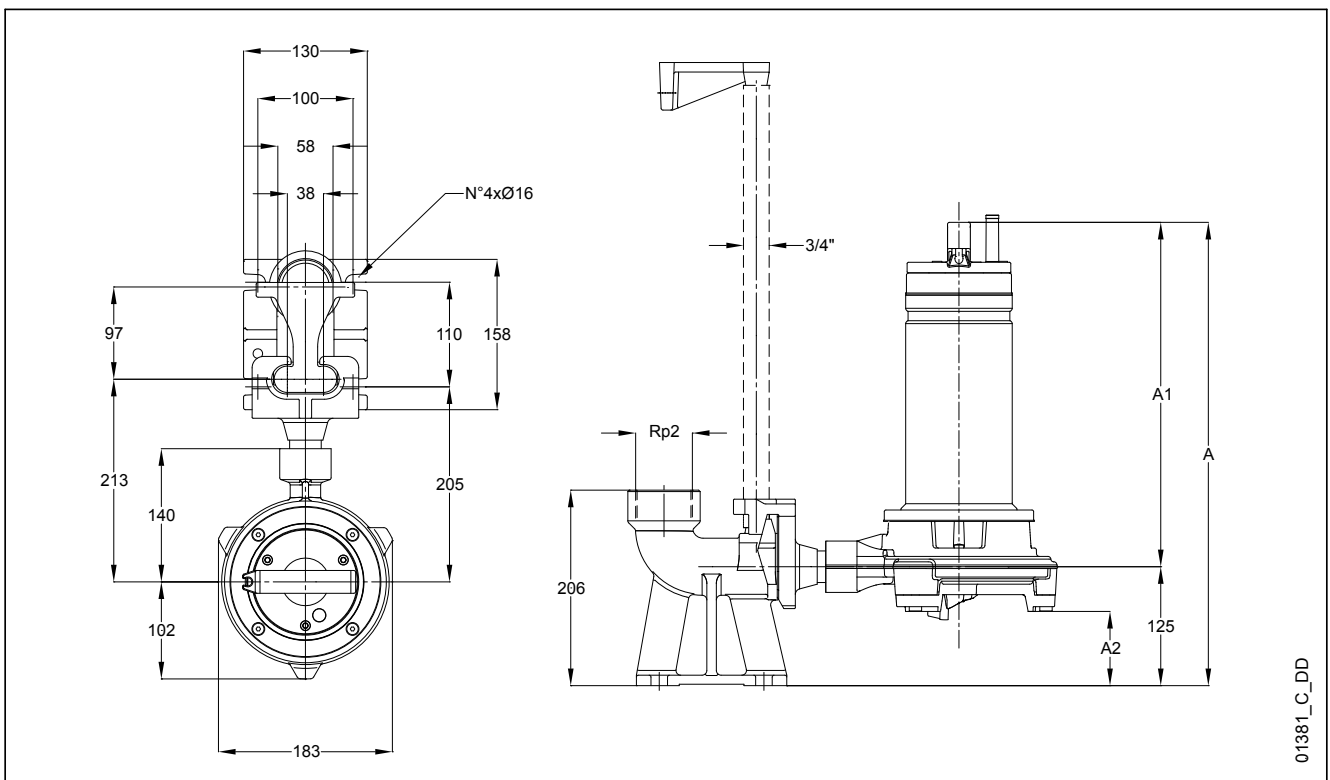

01381_C_DD

Submersible Electric Pumps for drainage of clean and slightly dirty water

DN Series

Drainage pumps with up to 22 metres head and up to 280 l/min (16,8 m³/h) delivery. This range consists of three pumps with up to 0,75 kW rated power.

APPLICATIONS

- Draining of flooded excavations and marshy ground.
- Irrigation from rainwater reservoirs, ditches, ponds and watercourses.



SPECIFICATIONS

- **Maximum liquid temperature:**
 - 50°C with fully submerged pump.
 - 25°C with partially submerged pump.
- Open **impeller** with **abrasion-resistant** rubber coating.
- **Mechanical seal** protected by **sand labyrinth**.
- Maximum dimension of **suspended solids: 5 mm**.
- **Motor** in a dielectric non-toxic **oil bath**, which ensures the lubrication of the ball bearings and a more efficient cooling.
 - **Power cord: H07RN-F.**
 - single-phase: with plug.
 - three-phase: without plug.
- **Insulation class 155°C (F).**
- **IPX8 protection.**
- **Maximum immersion depth: 5 m.**
- **Versions:**
 - Single-phase: 220-240V, 50Hz 2 poles.
 - Three-phase: 220-240V, 50Hz 2 poles. 380-415V, 50Hz 2 poles.
- **The single-phase versions** feature:
 - **capacitor** housed in a box on the
 - power cord + 1,5 m. power cord with plug.
 - **thermal overload protection** to stop pump supply in case of overheating.
- CG versions (single-phase with pre-assembled float switch), 60 Hz single-phase and three-phase versions, versions with various power cord lengths and various plugs are available on request.

DN SERIES IDENTIFICATION CODE

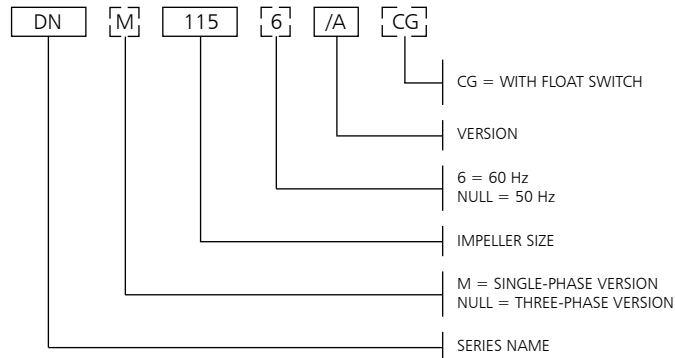

EXAMPLE : DNM 115/A
 DN Series Electric pump, impeller size 115,
 50 Hz version, single-phase, /A version.

SINGLE-PHASE RATING PLATE

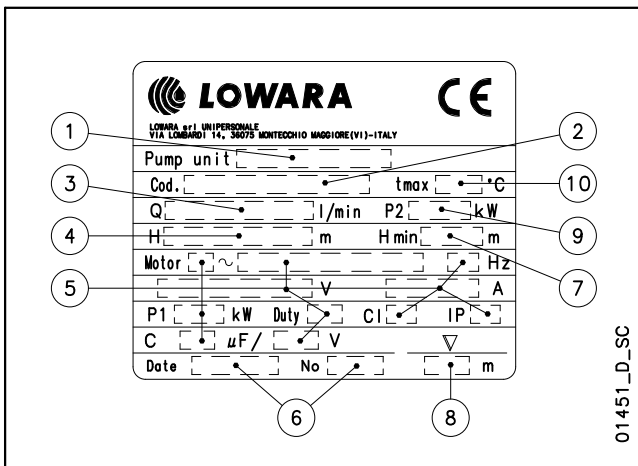

LEGEND

- 1 - Electric pump type
- 2 - Code
- 3 - Delivery range
- 4 - Head range
- 5 - Motor type
- 6 - Date of manufacture and serial number
- 7 - Minimum head
- 8 - Maximum immersion depth
- 9 - Rated output
- 10 - Maximum liquid temperature

THREE-PHASE RATING PLATE

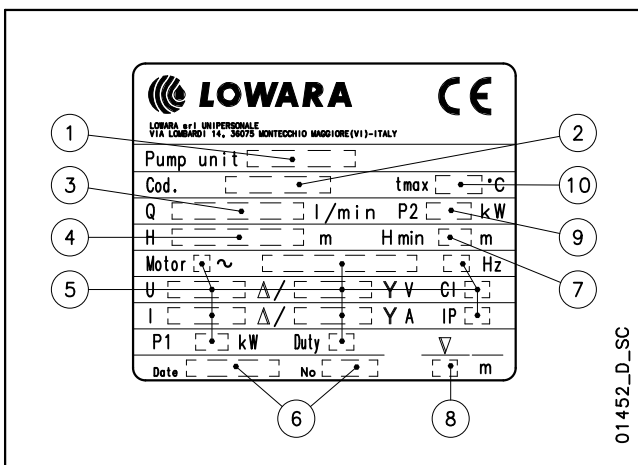

DN SERIES TABLE OF MATERIALS

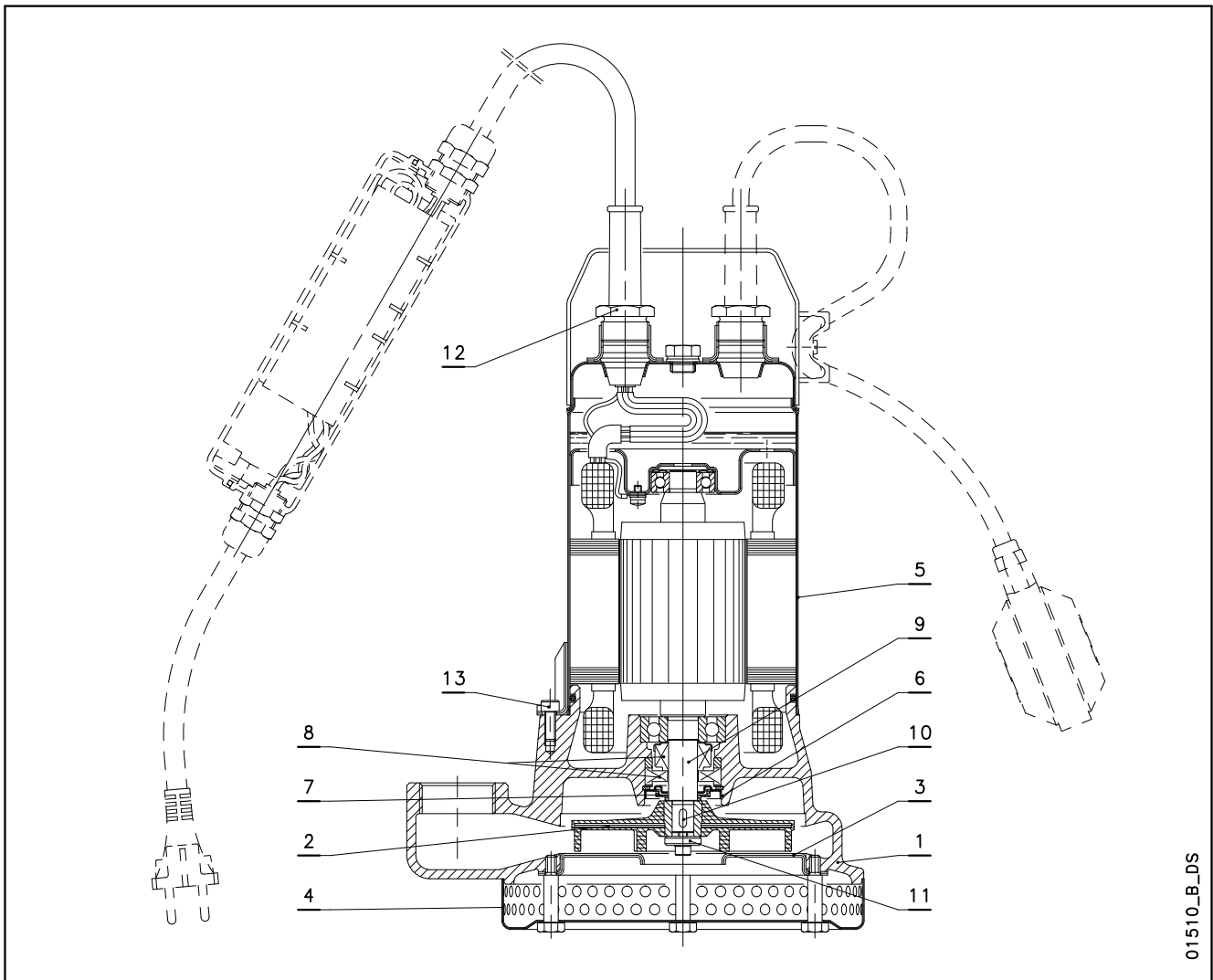

01510_B_DS

REF. N.	NAME	MATERIAL	REFERENCE STANDARDS	
			EUROPE	USA
1	Pump body	Cast iron	EN 1561-GJL-200(JL1030)	ASTM Class 25
2	Impeller	Steel + Nitrile Rubber XNBR		
3	Wearing flange	Stainless steel	EN 10088-1-X5CrNi18-10 (1.4301)	AISI 304
4	Suction strainer	Stainless steel	EN 10088-1-X5CrNi18-10 (1.4301)	AISI 304
5	Motor casing	Stainless steel	EN 10088-1-X5CrNi18-10 (1.4301)	AISI 304
6	Labyrinth cover	Stainless steel	EN 10088-1-X5CrNi18-10 (1.4301)	AISI 304
7	Labyrinth insert	NBR (standard version)		
8	Mechanical seal	Carbon / Ceramic Alumina / NBR (standard version)		
9	Shaft end	Stainless steel	EN 10088-1-X5CrNi18-10 (1.4301)	AISI 304
10	Key	Stainless steel	EN 10088-1-X5CrNiMo17-12-2 (1.4401)	AISI 316
11	Washer	Stainless steel		AISI 303
12	Cable gland	Brass		
13	Screws	Stainless steel	EN 10088-1-X5CrNi18-10 (1.4301)	AISI 304

dn-en_b_tm

DN SERIES MECHANICAL SEAL

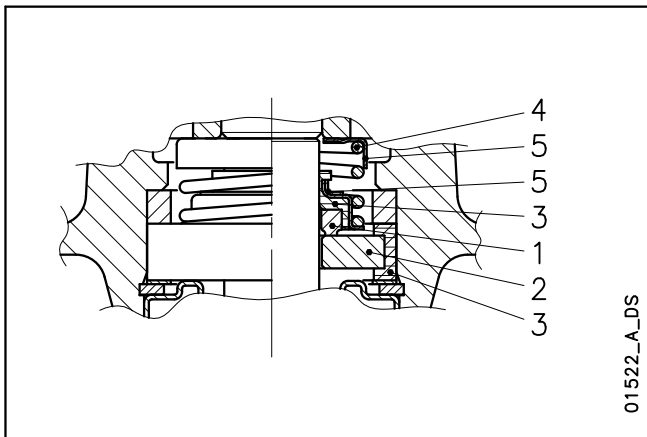

LIST OF MATERIALS

POSITION 1 - 2	POSITION 3	POSITION 4 - 5
B : Carbon	P : NBR	F : AISI 304
V : Ceramic Alumina		

dn-dl-dlv_ten-mec-en_c_tm

SEAL TYPES

TYPE	POSITION					TEMPERATURE (°C)
	1 ROTATING ASSEMBLY	2 FIXED ASSEMBLY	3 ELASTOMERS	4 SPRINGS	5 OTHER COMPONENTS	
STANDARD MECHANICAL SEAL						
BVPFF	B	V	P	F	F	0 +50

dn-dl-dlv_tipi-ten-mec-en_b_tc

DN SERIES OPERATING CHARACTERISTICS AT 50 Hz

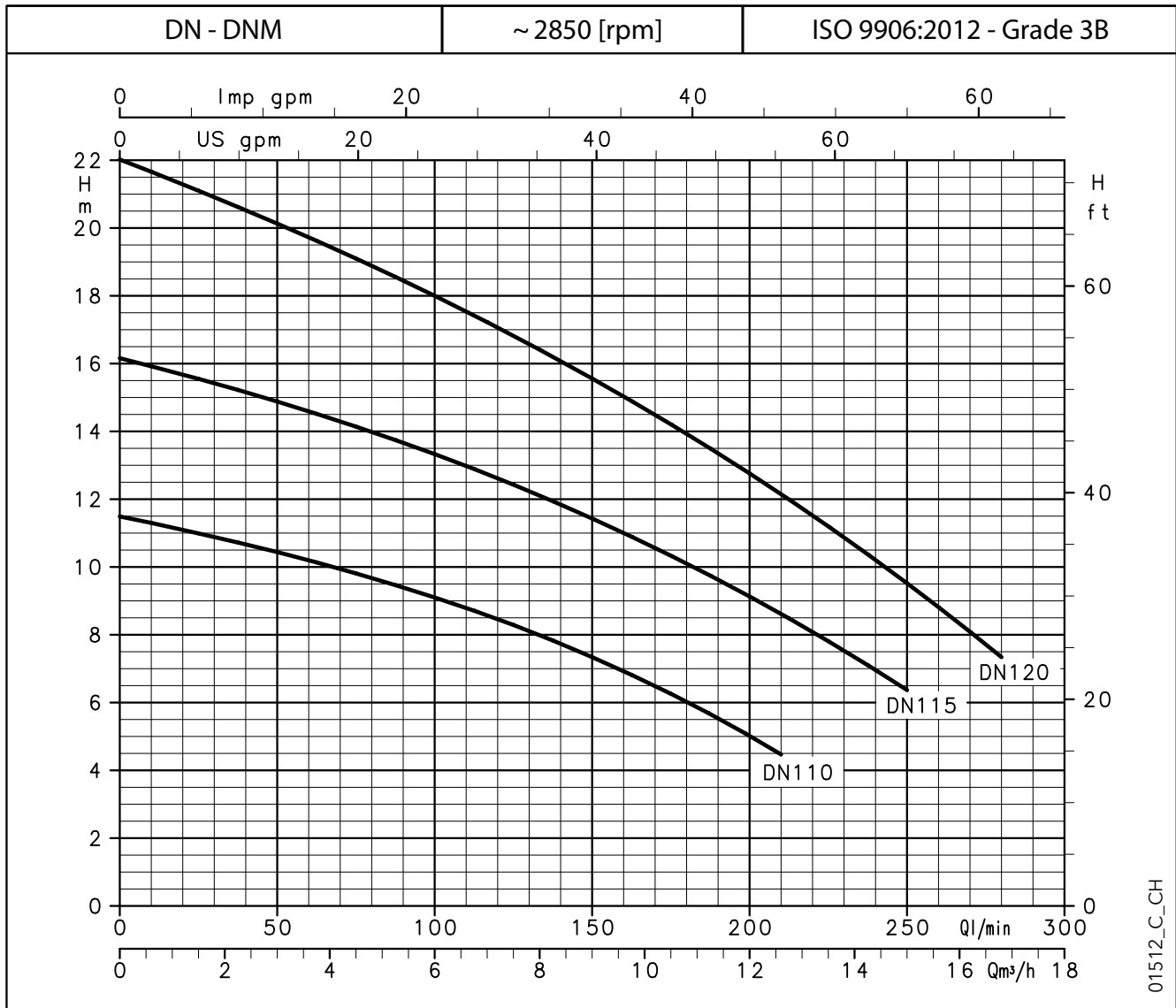

HYDRAULIC PERFORMANCE TABLE

PUMP TYPE	RATED POWER		Q = DELIVERY												
			l/min	0	25	50	75	100	125	150	175	210	225	250	280
			m ³ /h	0	1,5	3	4,5	6	7,5	9	10,5	12,6	13,5	15	16,8
			H = TOTAL HEAD METRES COLUMN OF WATER												
DN(M) 110	0,6	0,8	11,5	11,0	10,4	9,8	9,1	8,3	7,3	6,3	4,5				
DN(M) 115	0,6	0,8	16,2	15,6	14,9	14,1	13,3	12,4	11,4	10,3	8,6	7,8	6,4		
DN(M) 120	0,75	1	22,0	21,1	20,1	19,1	18,0	16,8	15,6	14,2	12,1	11,2	9,5	7,3	

These performances are valid for liquids with density $\rho = 1,0 \text{ kg/dm}^3$ and kinematic viscosity $\nu = 1 \text{ mm}^2/\text{s}$.

dn-2p50-en_a_th

ELECTRICAL DATA TABLE

PUMP TYPE	ABSORBED POWER*	ABSORBED CURRENT*	CAPACITOR
SINGLE-PHASE		220-240 V	
	kW	A	$\mu\text{F} / 450 \text{ V}$
DNM 110	0,68	3,56	25
DNM 115	0,90	4,28	25
DNM 120	1,03	4,77	25

PUMP TYPE	ABSORBED POWER*	ABSORBED CURRENT*	ABSORBED CURRENT*
THREE-PHASE		220-240 V	380-415 V
	kW	A	A
DN 110	0,66	3,46	2,00
DN 115	0,93	3,81	2,20
DN 120	1,09	4,05	2,34

*Maximum values within operating range.

dn-2p50-en_b_te

**DN SERIES
DIMENSIONS AND WEIGHTS**

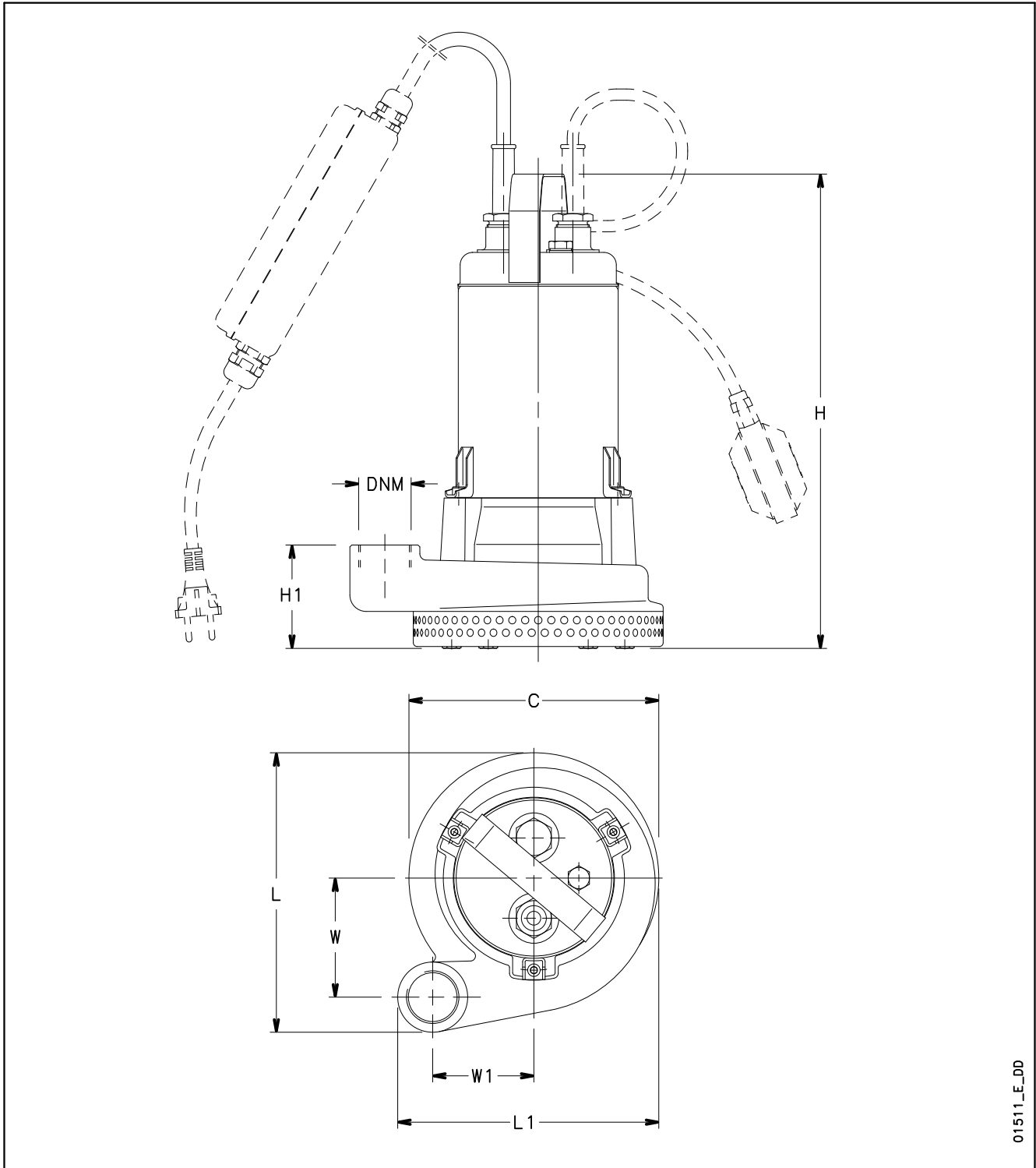

01511_E_DD

PUMP TYPE	DIMENSIONS (mm)							DNM	WEIGHT kg
	C	H	H1	L	L1	W	W1		
DNM110-DN110	Ø 200	380	81	223	209	95	81	Rp 1¼	18,5
DNM115-DN115	Ø 200	380	81	223	209	95	81	Rp 1¼	18,5
DNM120-DN120	Ø 200	380	81	223	209	95	81	Rp 1¼	19,5

dn-2p50-en_b_td

Submersible Electric Pumps for pumping sewage

DL Series

The DL series electric pumps come with single-channel or Vortex impeller (DLV), and are designed to handle solids-laden wastewater, with up to 22 m head and 42 m³/h delivery. 0,6 kW to 1,5 kW rated power. Solids handled up to 50 mm in diameter.



APPLICATIONS

- Pumping of sewage with suspended solids and filaments.
- Emptying of sumps, septic tanks and wastewater discharge tanks.
- Draining of flooded excavations and marshy ground.

SPECIFICATIONS

- **Maximum liquid temperature:**
 - 50°C with fully submerged pump.
 - 25°C with partially submerged pump.
- **Mechanical seal** protected by **sand labyrinth.**
- Maximum dimension of **suspended solids:**
 - 45 mm for **DL80, DL90, DL105, MINIVORTEX, VORTEX.**
 - 50 mm for **DL109, DL125, DLV100, DLV115.**
 - **Motor** in a dielectric non-toxic **oil bath**, which ensures the lubrication of the ball bearings and a more efficient cooling.
- **Power cord: H07RN-F.**
 - single-phase: with plug.
 - three-phase: without plug.
- **Insulation class 155°C (F).**
- **IPX8 protection.**
- **Maximum immersion depth: 5 m.**
- **Versions:**
 - Single-phase: 220-240V, 50Hz 2 poles.
 - Three-phase: 220-240V, 50Hz 2 poles. 380-415V, 50Hz 2 poles.
- **The single-phase versions** feature:
 - **capacitor** housed in a box on the power cord + 1,5 m. power cord with plug.
 - **thermal overload protection** to stop pump supply in case of overheating.
- CG versions (single-phase with pre-assembled float switch), 60 Hz single-phase and three-phase versions, versions with various power cord lengths and various plugs are available on request.

DL - DLV SERIES IDENTIFICATION CODE

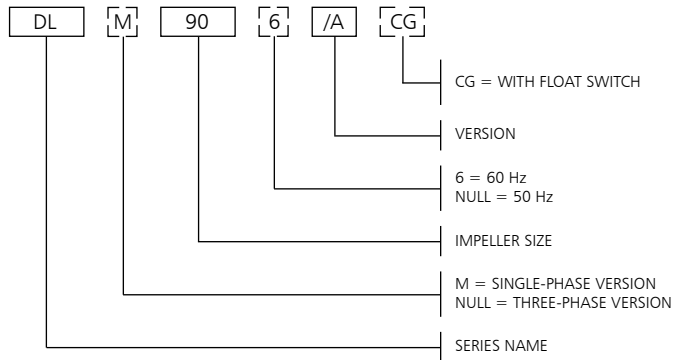

EXAMPLE : DLM 90/A
DL Series electric pump, impeller size 90,
50 Hz version, single-phase, /A version.

SINGLE-PHASE RATING PLATE

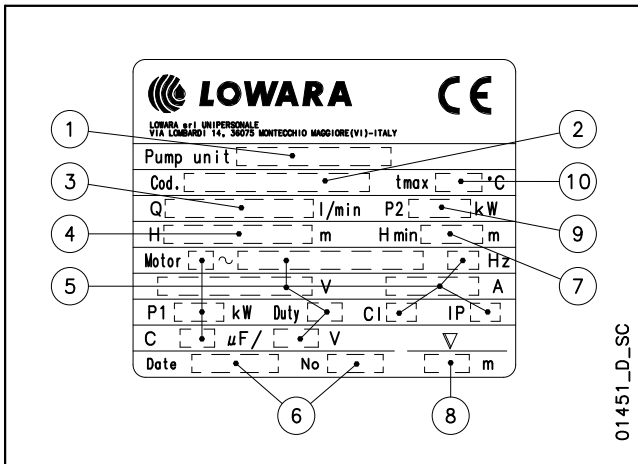

LEGEND

- 1 - Electric pump type
- 2 - Code
- 3 - Delivery range
- 4 - Head range
- 5 - Motor type
- 6 - Date of manufacture and serial number
- 7 - Minimum head
- 8 - Maximum immersion depth
- 9 - Rated output
- 10 - Maximum liquid temperature

THREE-PHASE RATING PLATE

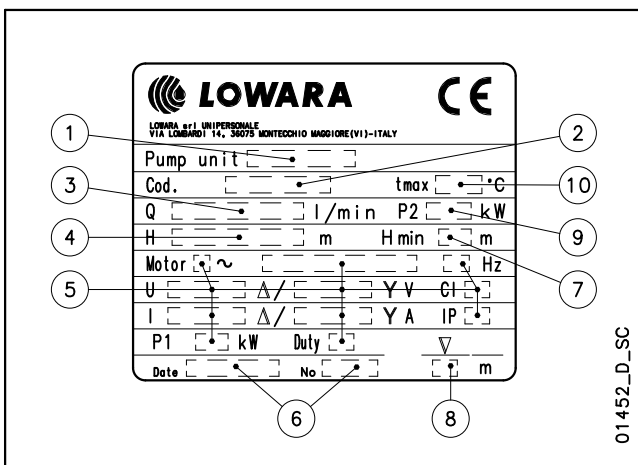

DL - VORTEX SERIES LIST OF MODELS AND TABLE OF MATERIALS

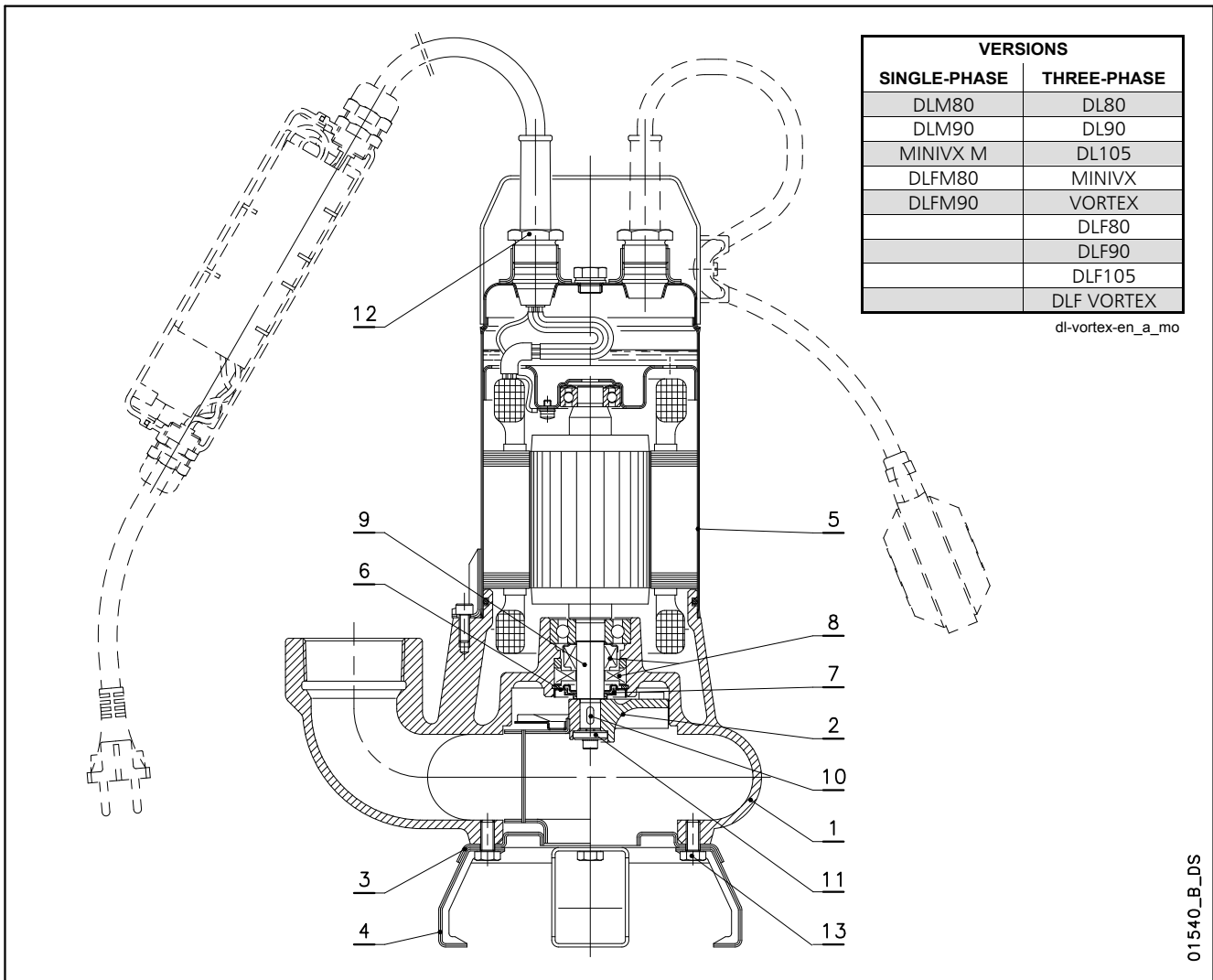

REF. N.	NAME	MATERIAL	REFERENCE STANDARDS	
			EUROPE	USA
1	Pump body	Cast iron	EN 1561-GJL-200(JL1030)	ASTM Class 25
2	Vortex impeller	Cast iron	EN 1561-GJL-200(JL1030)	ASTM Class 25
	Single-channel impeller	Stainless steel	EN 10088-1-X5CrNi18-10 (1.4301)	AISI 304
3	Suction flange	Stainless steel	EN 10088-1-X5CrNi18-10 (1.4301)	AISI 304
4	Support foot	Stainless steel	EN 10088-1-X5CrNi18-10 (1.4301)	AISI 304
5	Motor casing	Stainless steel	EN 10088-1-X5CrNi18-10 (1.4301)	AISI 304
6	Labyrinth cover	Stainless steel	EN 10088-1-X5CrNi18-10 (1.4301)	AISI 304
7	Labyrinth insert	NBR (standard version)		
8	Mechanical seal	Carbon / Ceramic Alumina / NBR (standard version)		
9	Shaft end	Stainless steel	EN 10088-1-X5CrNi18-10 (1.4301)	AISI 304
10	Key	Stainless steel	EN 10088-1-X5CrNiMo17-12-2 (1.4401)	AISI 316
11	Washer	Stainless steel		AISI 303
12	Cable gland	Brass		
13	Screws	Stainless steel	EN 10088-1-X5CrNi18-10 (1.4301)	AISI 304

dl-vortex-en_b_tm

DL - DLV SERIES LIST OF MODELS AND TABLE OF MATERIALS

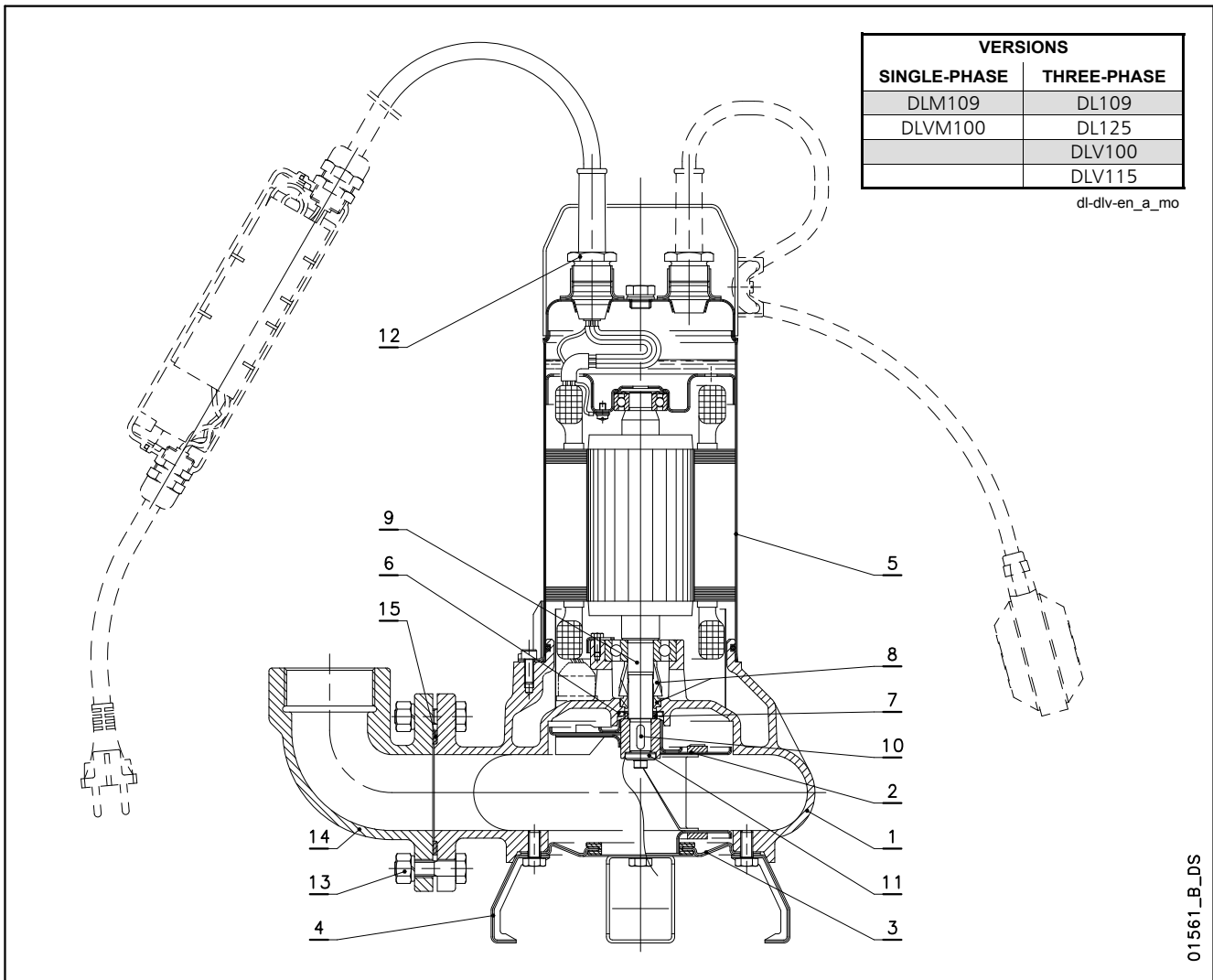

REF. N.	NAME	MATERIAL	REFERENCE STANDARDS	
			EUROPE	USA
1	Pump body	Cast iron	EN 1561-GJL-200(JL1030)	ASTM Class 25
2	Vortex impeller	Stainless steel	EN 10088-1-X5CrNi18-10 (1.4301)	AISI 304
	Single-channel impeller	Stainless steel	EN 10088-1-X5CrNi18-10 (1.4301)	AISI 304
3	Suction flange	Stainless steel	EN 10088-1-X5CrNi18-10 (1.4301)	AISI 304
4	Support foot	Stainless steel	EN 10088-1-X5CrNi18-10 (1.4301)	AISI 304
5	Motor casing	Stainless steel	EN 10088-1-X5CrNi18-10 (1.4301)	AISI 304
6	V-RING Cover	Stainless steel	EN 10088-1-X5CrNi18-10 (1.4301)	AISI 304
7	V16A Seal ring	NBR (standard version)		
8	Mechanical seal	Carbon / Ceramic Alumina / NBR (standard version)		
9	Shaft end	Stainless steel	EN 10088-1-X5CrNi18-10 (1.4301)	AISI 304
10	Key	Stainless steel	EN 10088-1-X5CrNiMo17-12-2 (1.4401)	AISI 316
11	Washer	Stainless steel		AISI 303
12	Cable gland	Brass		
13	Screws	Stainless steel	EN 10088-1-X5CrNi18-10 (1.4301)	AISI 304
14	Delivery connection	Cast iron	EN 1561-GJL-200(JL1030)	ASTM Class 25
15	Delivery connection gasket	Nitrile rubber		

di-dlv-en_b_tm

DL80 - DL90 - DL105 - MINIVORTEX - VORTEX SERIES MECHANICAL SEAL

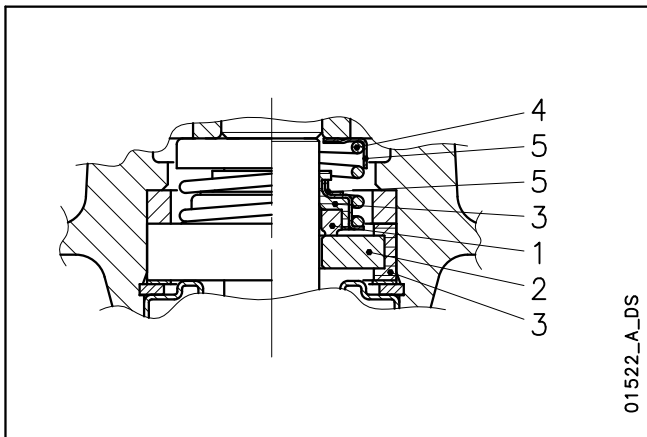

LIST OF MATERIALS

POSITION 1 - 2	POSITION 3	POSITION 4 - 5
B : Carbon	P : NBR	F : AISI 304
V : Ceramic Alumina		

dn-dl-dlv_ten-mec-en_c_tm

SEAL TYPES

TYPE	POSITION					TEMPERATURE (°C)
	1 ROTATING ASSEMBLY	2 FIXED ASSEMBLY	3 ELASTOMERS	4 SPRINGS	5 OTHER COMPONENTS	
STANDARD MECHANICAL SEAL						
BVPFF	B	V	P	F	F	0 +50

dn-dl-dlv_tipi-ten-mec-en_b_tc

DL109 - DL125 - DLV100 - DLV115 SERIES MECHANICAL SEAL

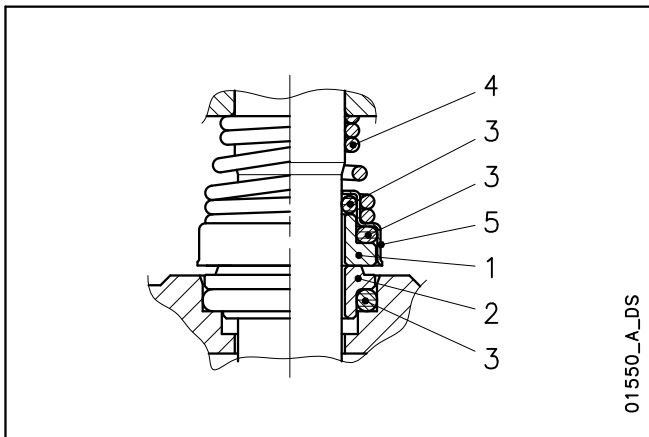

LIST OF MATERIALS

POSITION 1 - 2	POSITION 3	POSITION 4 - 5
B : Carbon	P : NBR	G : AISI 316
U₃ : Tungsten Carbide	V : FPM	F : AISI 304
V : Ceramic Alumina		

dl-dlv_ten-mec-en_a_tm

SEAL TYPES

TYPE	POSITION					TEMPERATURE (°C)
	1 ROTATING ASSEMBLY	2 FIXED ASSEMBLY	3 ELASTOMERS	4 SPRINGS	5 OTHER COMPONENTS	
STANDARD MECHANICAL SEAL						
VBPGF	V	B	P	G	F	0 +50
OTHER MECHANICAL SEAL TYPES						
U ₃ U ₃ VFF	U ₃	U ₃	V	F	F	0 +50

dl-dlv_tipi-ten-mec-en_b_tc

DL SERIES OPERATING CHARACTERISTICS AT 50 Hz

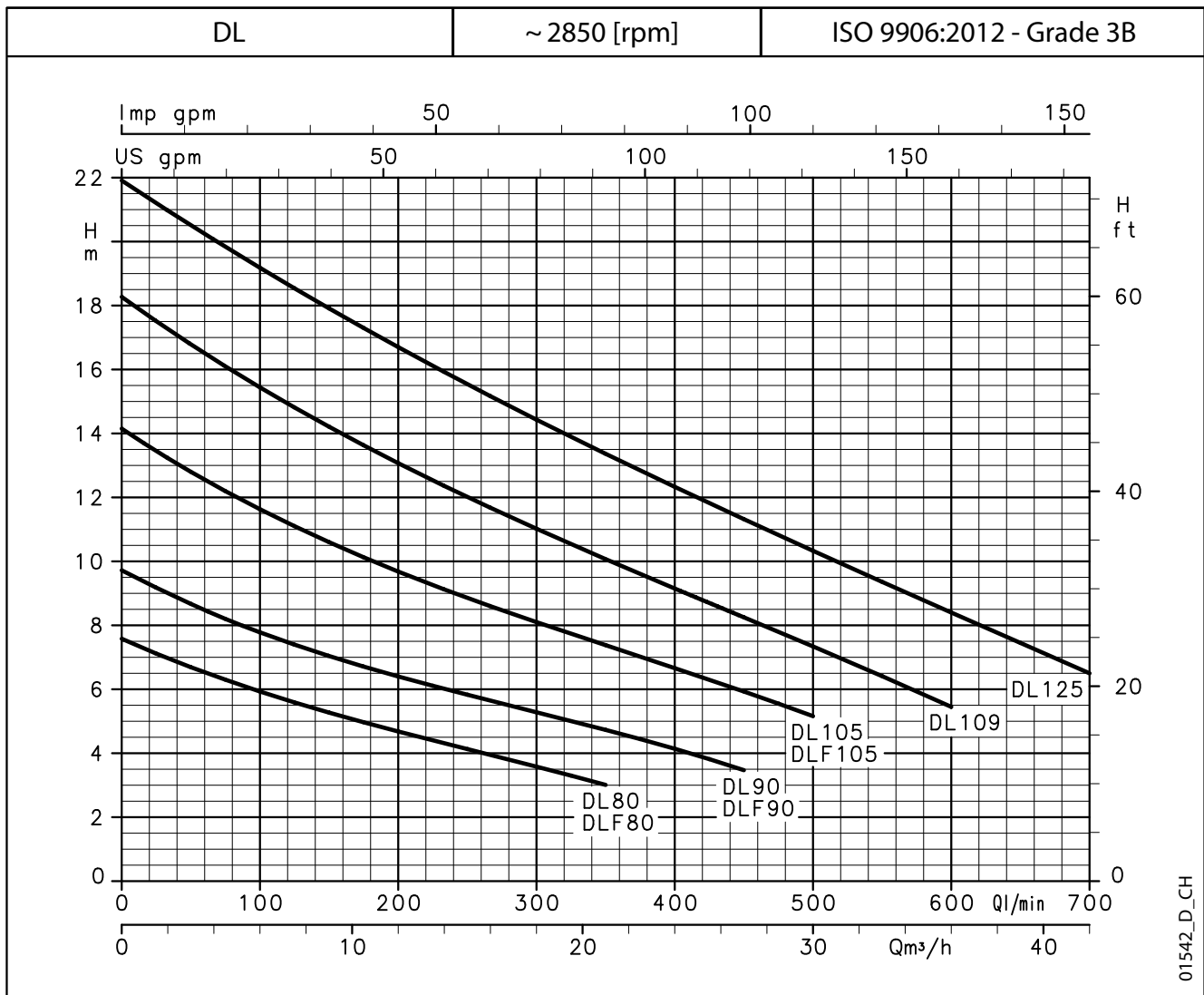

HYDRAULIC PERFORMANCE TABLE

PUMP TYPE	RATED POWER		Q = DELIVERY												
			H = TOTAL HEAD METRES COLUMN OF WATER												
			l/min	0	100	150	200	250	300	350	400	450	500	600	700
			m ³ /h	0	6	9	12	15	18	21	24	27	30	36	42
DL(M) 80-DLF(M) 80	0,6	0,8		7,6	5,9	5,3	4,7	4,1	3,6	3,0					
DL(M) 90-DLF(M) 90	0,6	0,8		9,7	7,8	7,0	6,4	5,8	5,3	4,7	4,1	3,5			
DL 105 - DLF105	1,1	1,5		14,1	11,6	10,6	9,7	8,9	8,1	7,4	6,7	5,9	5,2		
DL(M) 109	1,1	1,5		18,3	15,4	14,2	13,1	12,0	11,0	10,1	9,2	8,2	7,3	5,4	
DL 125	1,5	2		21,9	19,2	17,9	16,7	15,5	14,4	13,4	12,3	11,3	10,3	8,4	6,5

These performances are valid for liquids with density $\rho = 1,0 \text{ kg/dm}^3$ and kinematic viscosity $\nu = 1 \text{ mm}^2/\text{s}$.

dl-2p50-en_b_th

ELECTRICAL DATA TABLE

PUMP TYPE	ABSORBED POWER*	ABSORBED CURRENT*	CAPACITOR
	kW	A	$\mu\text{F} / 450 \text{ V}$
SINGLE-PHASE			
DLM80-DLFM80	0,79	3,91	25
DLM90-DLFM90	0,89	4,27	25
-	-	-	-
DLM109	1,55	6,87	35
-	-	-	-

PUMP TYPE	ABSORBED POWER*	ABSORBED CURRENT*	ABSORBED CURRENT*
	kW	A	A
THREE-PHASE			
DL80-DLF80	0,8	-	2,09
DL90-DLF90	0,92	3,81	2,2
DL105-DLF105	1,43	4,66	2,69
DL109	1,54	5,44	3,14
DL125	2,14	6,58	3,8

*Maximum values within operating range.

dl-2p50-en_b_th

DLV SERIES OPERATING CHARACTERISTICS AT 50 Hz

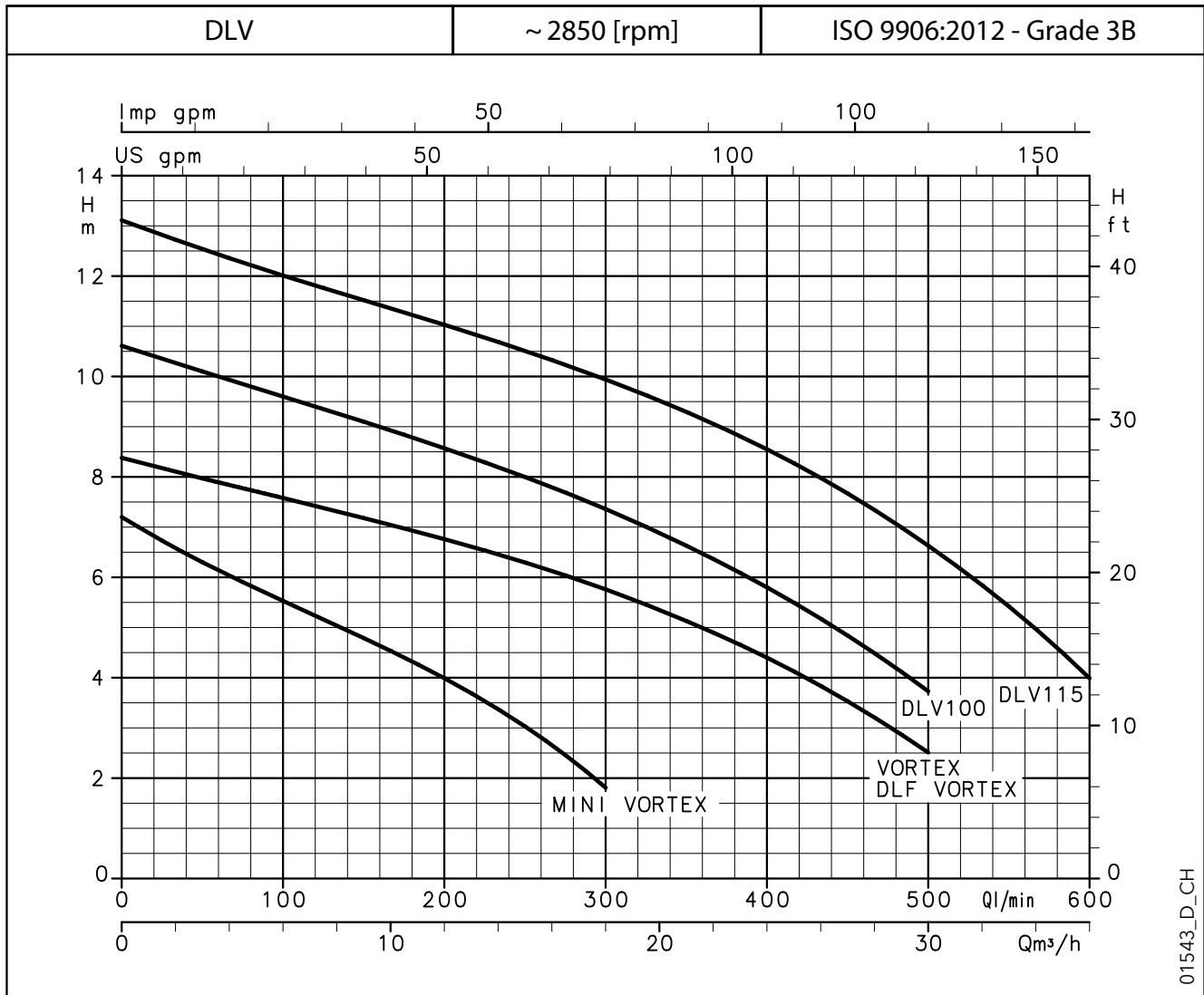

HYDRAULIC PERFORMANCE TABLE

PUMP TYPE	RATED POWER		Q = DELIVERY												
			l/min	50	100	150	200	250	300	350	400	450	500	600	
			m ³ /h	3	6	9	12	15	18	21	24	27	30	36	
	kW	HP	H = TOTAL HEAD METRES COLUMN OF WATER												
MINI VORTEX(M)	0,6	0,8	7,2	6,3	5,5	4,8	4,0	3,0	1,8						
VORTEX-DLF VORTEX	1,1	1,5	8,4	8,0	7,6	7,2	6,8	6,3	5,8	5,1	4,4	3,5	2,5		
DLV(M) 100	1,1	1,5	10,6	10,1	9,6	9,1	8,6	8,0	7,4	6,6	5,8	4,8	3,7		
DLV 115	1,5	2	13,1	12,5	12,0	11,5	11,0	10,5	9,9	9,3	8,5	7,7	6,6	4,0	

These performances are valid for liquids with density $\rho = 1,0 \text{ kg/dm}^3$ and kinematic viscosity $\nu = 1 \text{ mm}^2/\text{s}$.

dlv-2p50-en_b_th

ELECTRICAL DATA TABLE

PUMP TYPE	ABSORBED POWER*	ABSORBED CURRENT*	CAPACITOR
SINGLE-PHASE	kW	220-240 V A	$\mu\text{F} / 450 \text{ V}$
MINI VORTEX M	1,05	4,82	25
-	-	-	-
DLVM100	1,64	7,30	35
-	-	-	-

PUMP TYPE	ABSORBED POWER*	ABSORBED CURRENT*	ABSORBED CURRENT*
THREE-PHASE	kW	220-240 V A	380-415 V A
MINI VORTEX	1,10	-	2,36
VORTEX-DLF VORTEX	1,66	5,11	2,95
DLV 100	1,65	5,63	3,25
DLV 115	2,25	6,81	3,93

*Maximum values within operating range.

dlv-2p50-en_b_te

DL - VORTEX SERIES DIMENSIONS AND WEIGHTS

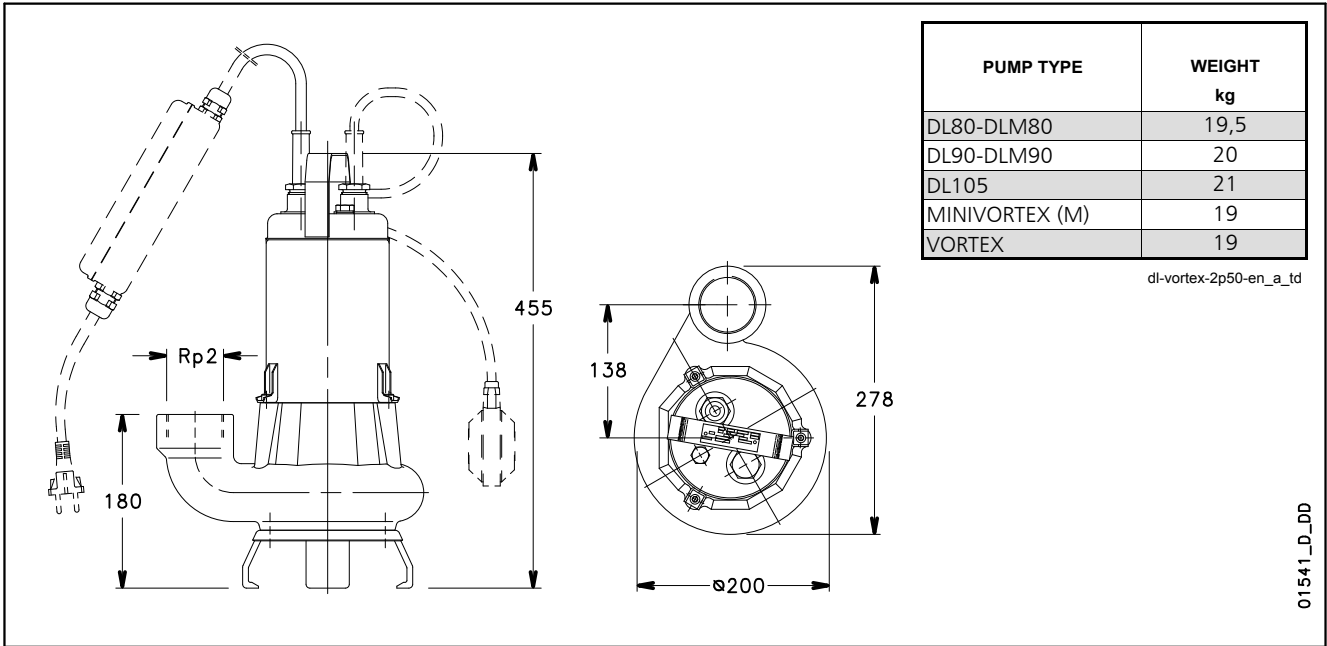

DLF SERIES INSTALLATION WITH SD LOWERING DEVICE

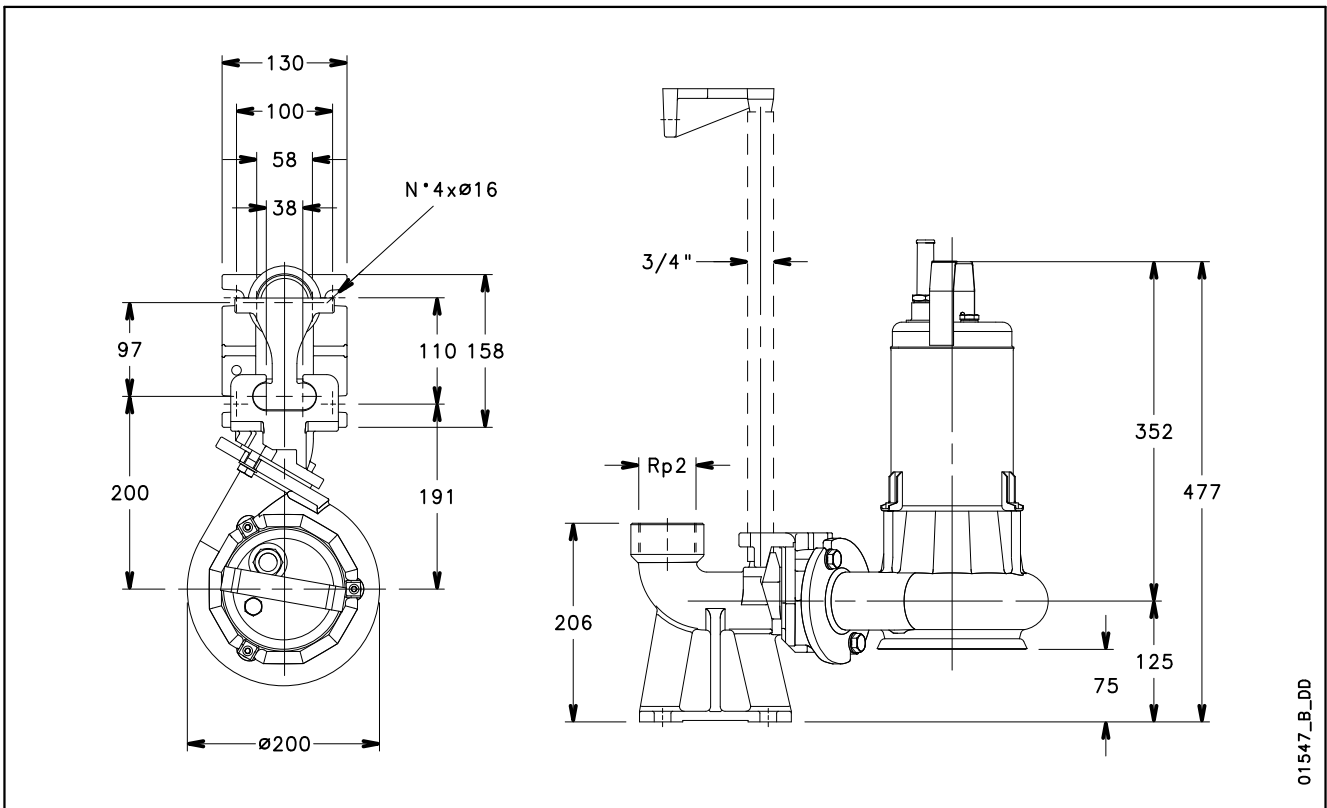

DL-DLV SERIES DIMENSIONS AND WEIGHTS

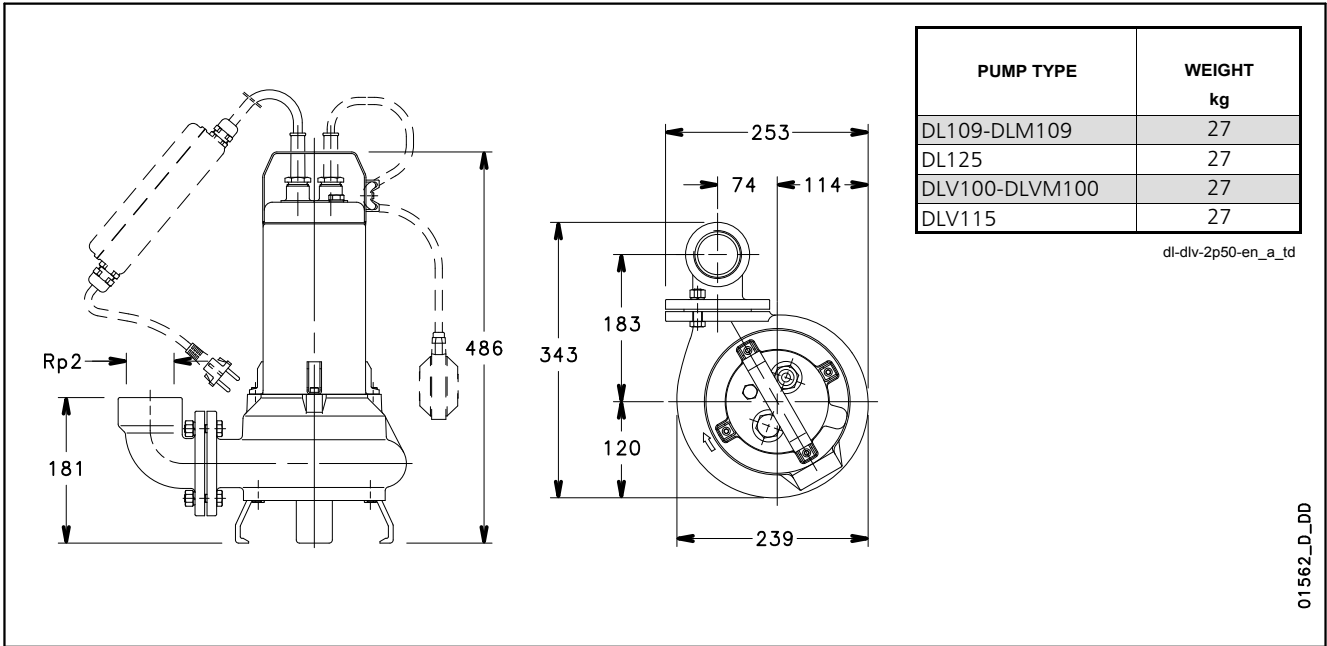

DL-DLV SERIES INSTALLATION WITH SD LOWERING DEVICE

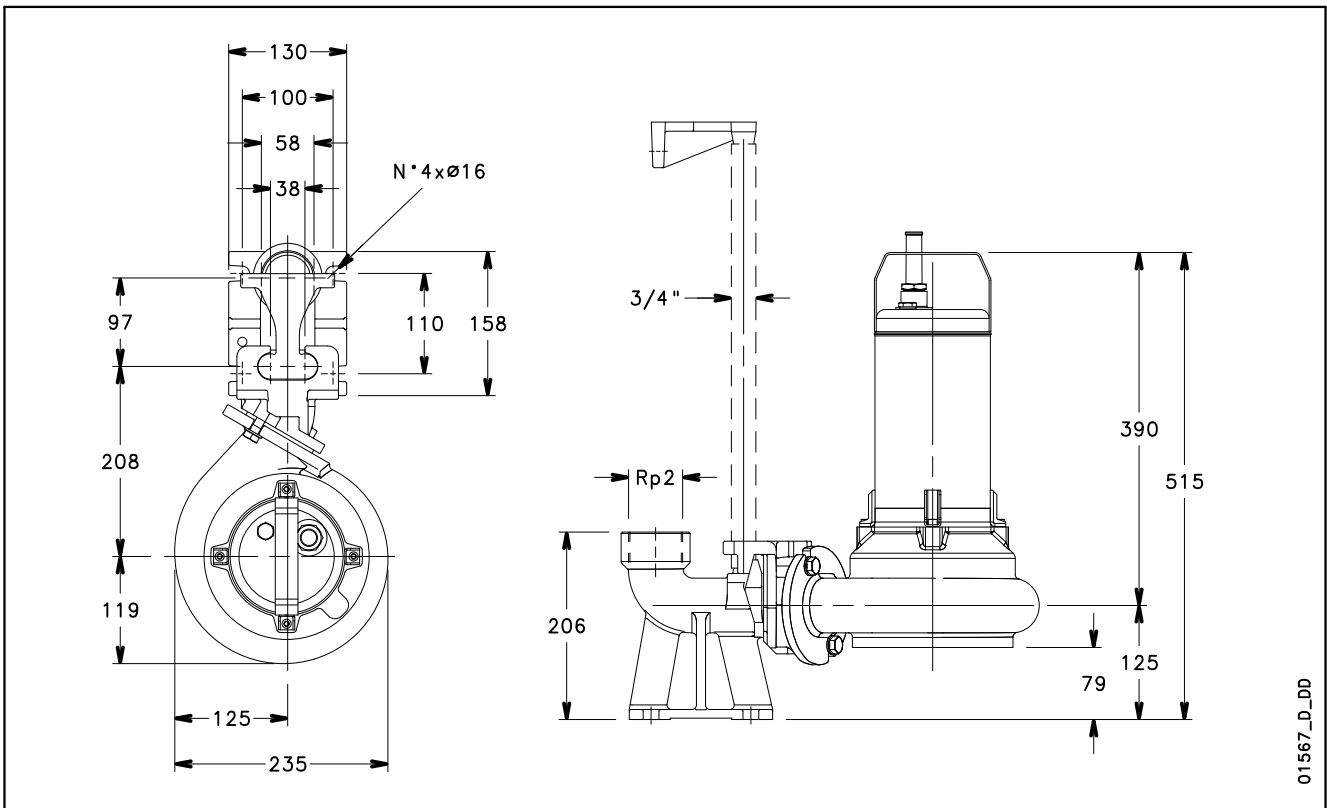

TECHNICAL APPENDIX

LEVEL REGULATORS

SMALL MODEL
(floating)

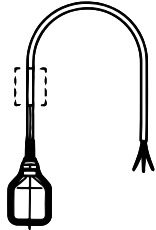

For single function (draining).
Cable lengths 1.5, 5, 10 m.
Counterweight available on request for versions with 5 and 10 m cable.

KEY MODEL
(floating)

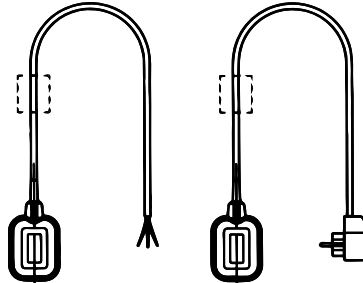

For dual function (draining/filling).
Cable lengths: 1.5, 5, 10, 20 m.
Counterweight available on request for versions with 5 and 10 m cable.
Version with plug and socket for single-phase pumps up to 1 kW.

RDN-10 MODEL
(tilting)

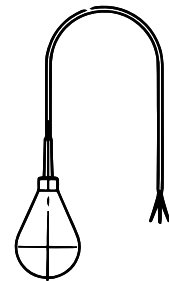

For solids-laden water.
Cable lengths:
10, 13, 15, 20, 30, 50 m.

BALL CHECK VALVES FOR WASTEWATER

No-clog, maximum reliability, low flow resistance.
Maximum operating pressure: 10 bar.
Maximum temperature: 85°C.
Horizontal and vertical operating position.

MODEL	DIMENSIONS (mm)			WEIGHT kg
	Ø BALL	L	H	
Rp 1 1/4	48	140	80	2
Rp 1 1/2	50	140	80	4
Rp 2	60	200	98	5,5
DN 65	95	230	148	12
DN 80	95	260	148	13
DN 100	120	300	182	18
DN 150	175	400	251	37,5
DN 200	240	500	333	70
DN 250	300	600	406	128

Valv-palla-en_a_td

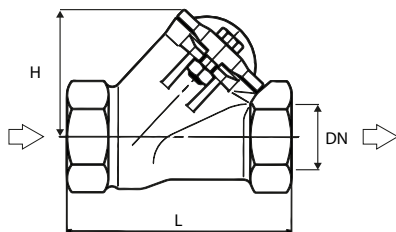

Rp 1 1/4 - 1 1/2 - 2 MODEL

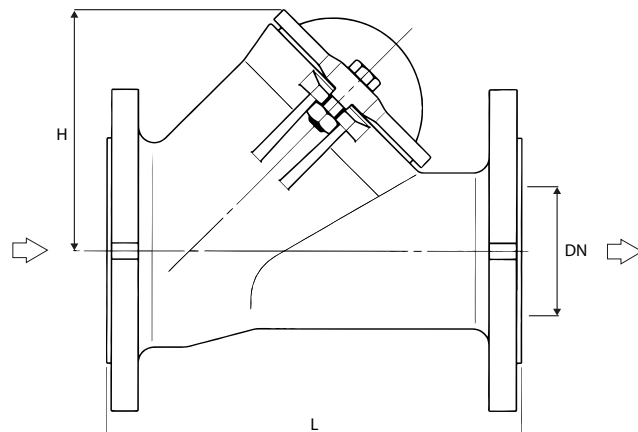

65 - 80 - 100 - 150 - 200 - 250 MODEL

**EXAMPLE OF INSTALLATION
OF SINGLE-PUMP SYSTEM**

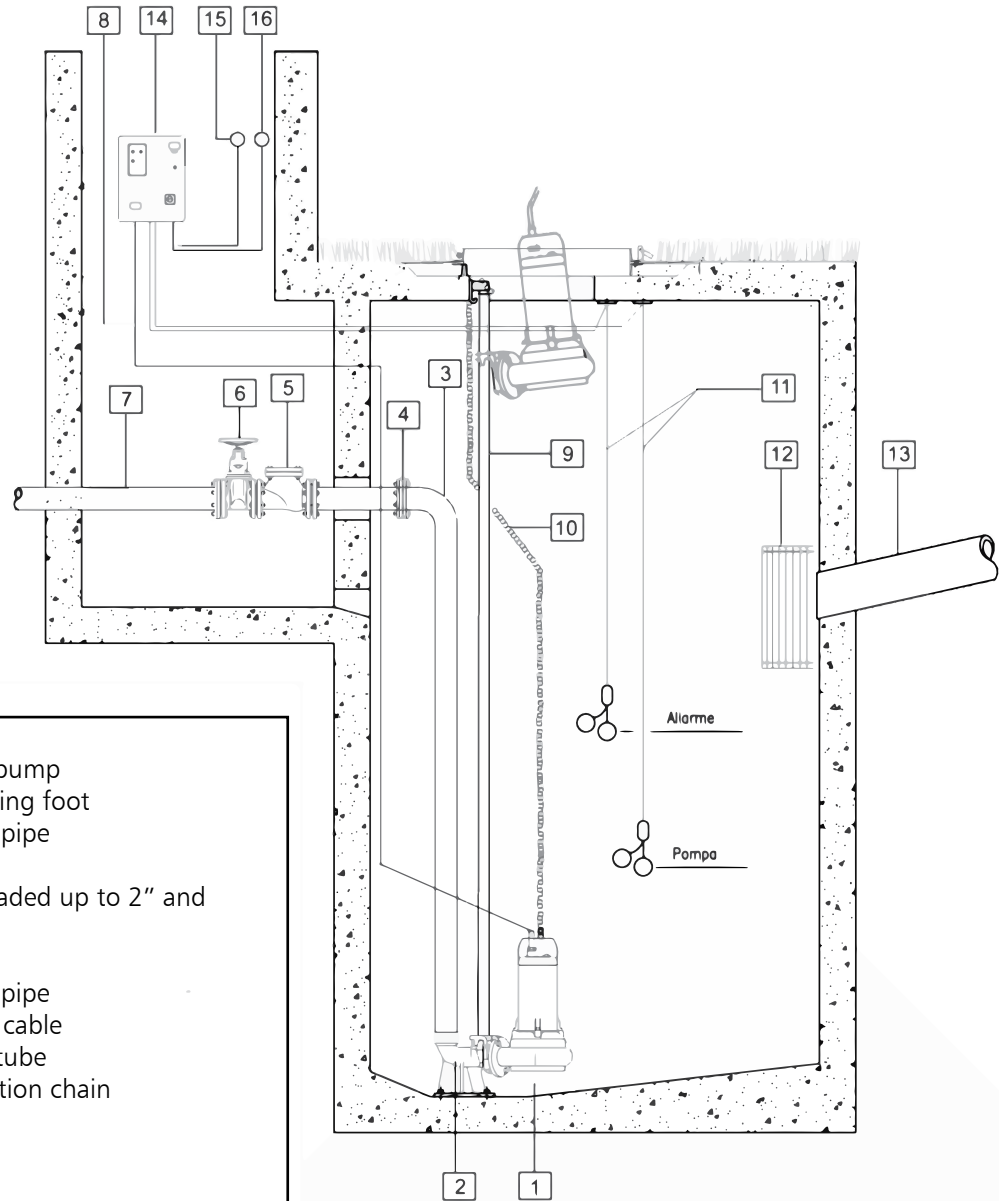

LEGEND

- 1- Submersible electric pump
- 2- Cast iron quick coupling foot
- 3- Polyethylene delivery pipe
- 4- Counterflange
- 5- Ball check valve, threaded up to 2" and flanged for higher DN
- 6- Gate valve
- 7- Polyethylene delivery pipe
- 8- Electric pump power cable
- 9- Stainless steel guide tube
- 10- Stainless steel extraction chain
- 11- Level floats
- 12- Inlet sluice gate
- 13- Inlet pipe
- 14- Electric panel
- 15- Alarm siren
- 16- Alarm light

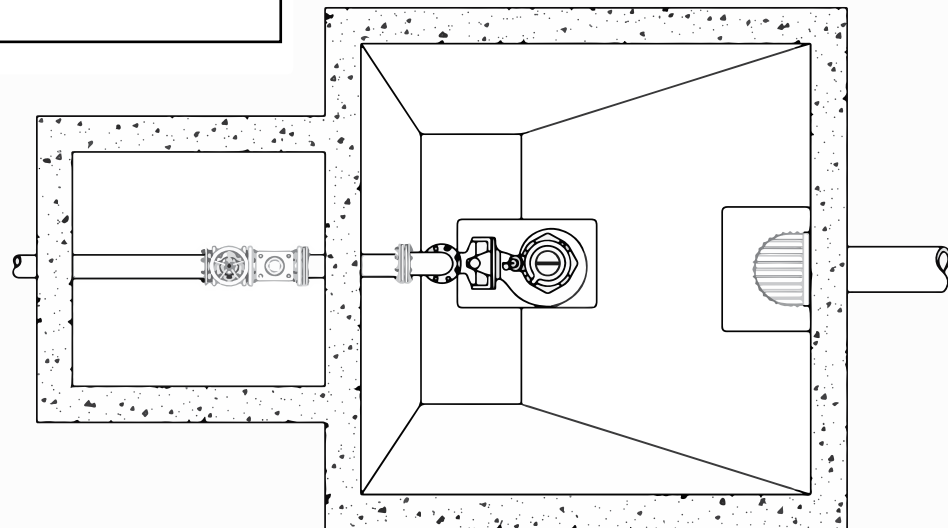

**EXAMPLE OF INSTALLATION OF
TWO-PUMPS SYSTEM WITH THREE LEVEL REGULATORS**

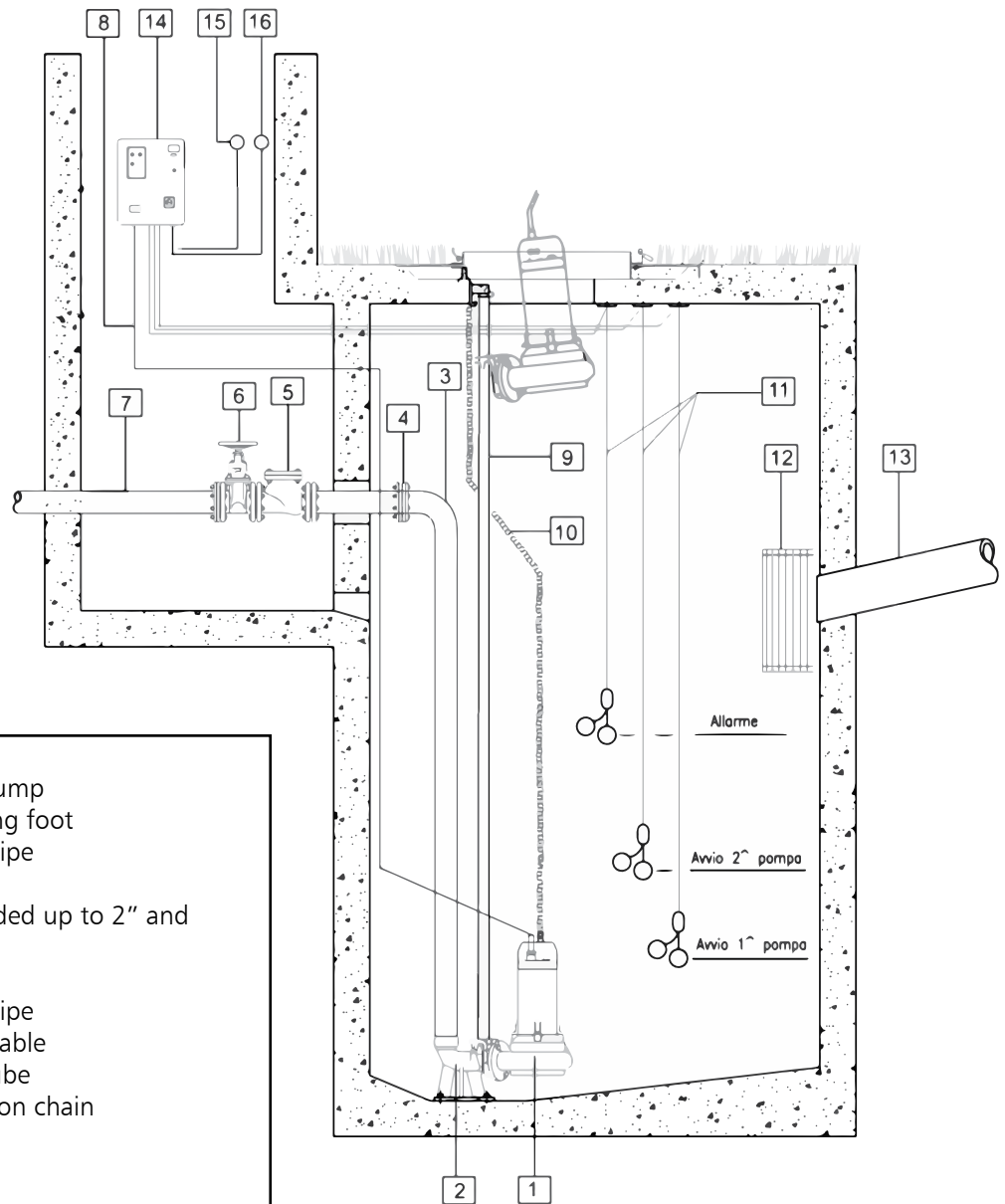

LEGEND

- 1- Submersible electric pump
- 2- Cast iron quick coupling foot
- 3- Polyethylene delivery pipe
- 4- Counterflange
- 5- Ball check valve, threaded up to 2" and flanged for higher DN
- 6- Gate valve
- 7- Polyethylene delivery pipe
- 8- Electric pump power cable
- 9- Stainless steel guide tube
- 10- Stainless steel extraction chain
- 11- Level floats
- 12- Inlet sluice gate
- 13- Inlet pipe
- 14- Electric panel
- 15- Alarm siren
- 16- Alarm light

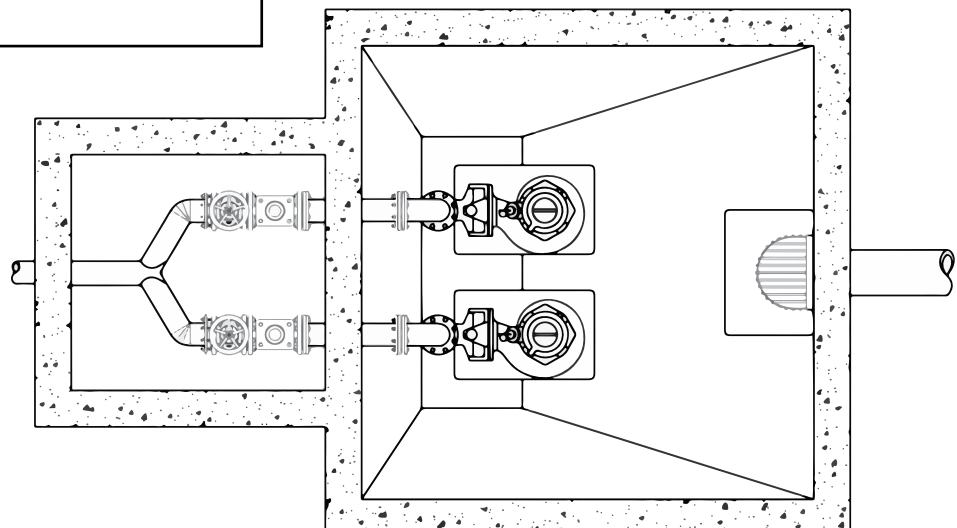

**EXAMPLE OF INSTALLATION OF
TWO-PUMPS SYSTEM WITH FOUR LEVEL REGULATORS**

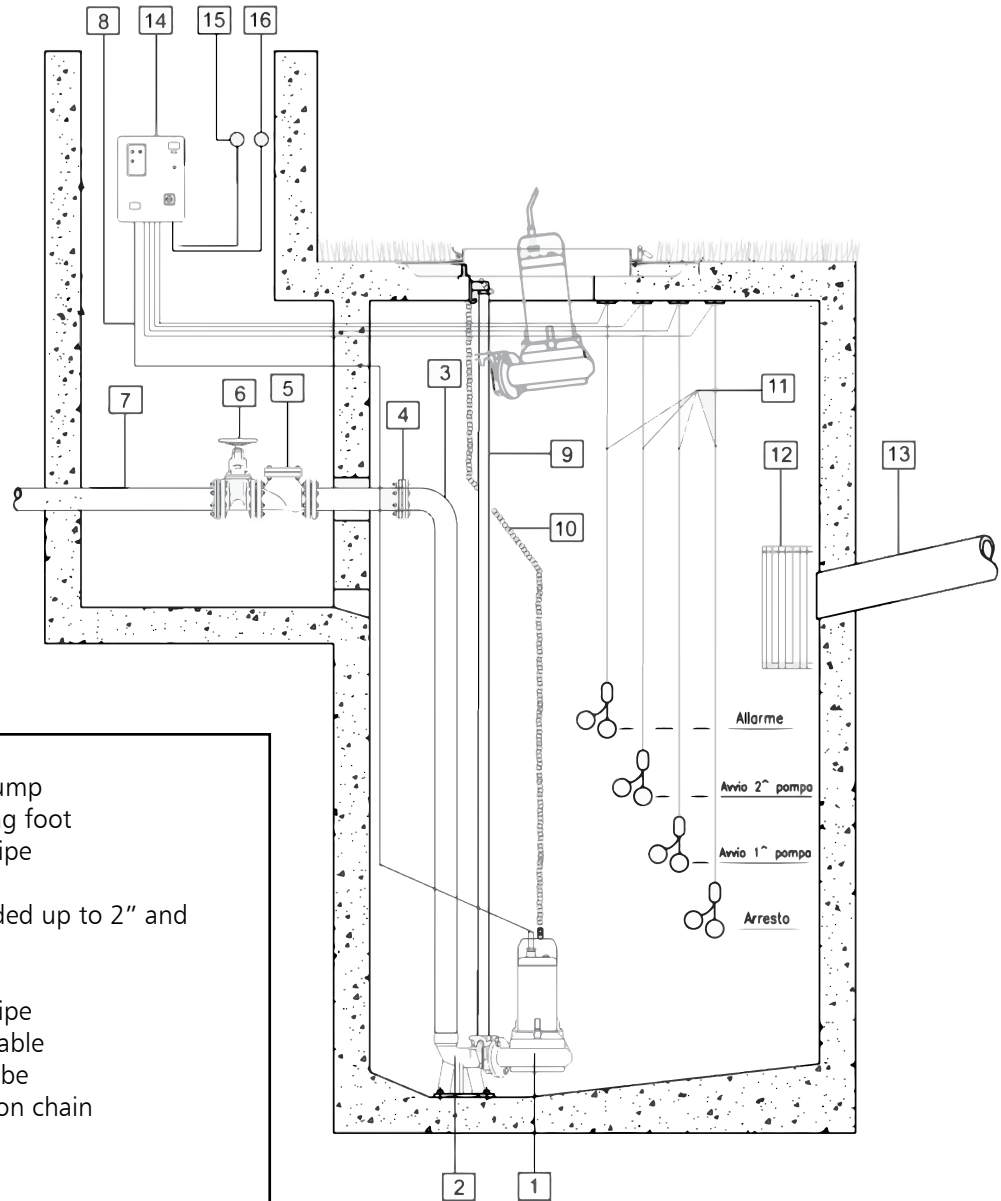

LEGEND

- 1- Submersible electric pump
- 2- Cast iron quick coupling foot
- 3- Polyethylene delivery pipe
- 4- Counterflange
- 5- Ball check valve, threaded up to 2" and flanged for higher DN
- 6- Gate valve
- 7- Polyethylene delivery pipe
- 8- Electric pump power cable
- 9- Stainless steel guide tube
- 10- Stainless steel extraction chain
- 11- Level floats
- 12- Inlet sluice gate
- 13- Inlet pipe
- 14- Electric panel
- 15- Alarm siren
- 16- Alarm light

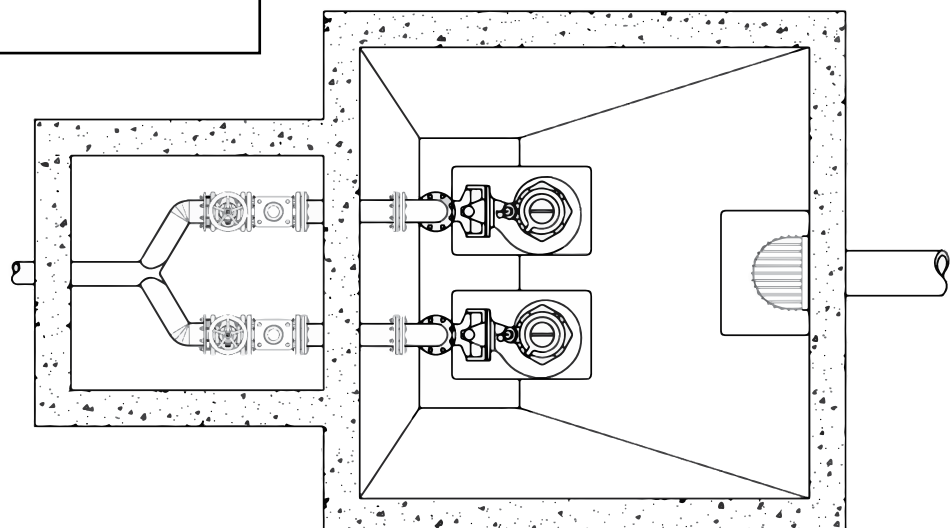



TABLE OF FLOW RESISTANCE IN 100 m OF STRAIGHT CAST IRON PIPELINE (HAZEN-WILLIAMS FORMULA C=100)

FLOW RATE		NOMINAL DIAMETER in mm and inches																		
m ³ /h	l/min		15	20	25	32	40	50	65	80	100	125	150	175	200	250	300	350	400	
			1/2"	3/4"	1"	1 1/4"	1 1/2"	2	2 1/2"	3"	4"	5"	6"	7"	8"	10"	12"	14"	16"	
0,6	10	v	0,94	0,53	0,34	0,21	0,13													
		hr	16	3,94	1,33	0,40	0,13													
0,9	15	v	1,42	0,80	0,51	0,31	0,20													
		hr	33,9	8,35	2,82	0,85	0,29													
1,2	20	v	1,89	1,06	0,68	0,41	0,27	0,17												
		hr	57,7	14,21	4,79	1,44	0,49	0,16												
1,5	25	v	2,36	1,33	0,85	0,52	0,33	0,21												
		hr	87,2	21,5	7,24	2,18	0,73	0,25												
1,8	30	v	2,83	1,59	1,02	0,62	0,40	0,25												
		hr	122	30,1	10,1	3,05	1,03	0,35												
2,1	35	v	3,30	1,86	1,19	0,73	0,46	0,30												
		hr	162	40,0	13,5	4,06	1,37	0,46												
2,4	40	v		2,12	1,36	0,83	0,53	0,34	0,20											
		hr		51,2	17,3	5,19	1,75	0,59	0,16											
3	50	v		2,65	1,70	1,04	0,66	0,42	0,25											
		hr		77,4	26,1	7,85	2,65	0,89	0,25											
3,6	60	v		3,18	2,04	1,24	0,80	0,51	0,30											
		hr		108	36,6	11,0	3,71	1,25	0,35											
4,2	70	v		3,72	2,38	1,45	0,93	0,59	0,35											
		hr		144	48,7	14,6	4,93	1,66	0,46											
4,8	80	v		4,25	2,72	1,66	1,06	0,68	0,40											
		hr		185	62,3	18,7	6,32	2,13	0,59											
5,4	90	v			3,06	1,87	1,19	0,76	0,45	0,30										
		hr			77,5	23,3	7,85	2,65	0,74	0,27										
6	100	v			3,40	2,07	1,33	0,85	0,50	0,33										
		hr			94,1	28,3	9,54	3,22	0,90	0,33										
7,5	125	v			4,25	2,59	1,66	1,06	0,63	0,41										
		hr			142	42,8	14,4	4,86	1,36	0,49										
9	150	v				3,11	1,99	1,27	0,75	0,50	0,32									
		hr				59,9	20,2	6,82	1,90	0,69	0,23									
10,5	175	v				3,63	2,32	1,49	0,88	0,58	0,37									
		hr				79,7	26,9	9,07	2,53	0,92	0,31									
12	200	v				4,15	2,65	1,70	1,01	0,66	0,42									
		hr				102	34,4	11,6	3,23	1,18	0,40									
15	250	v				5,18	3,32	2,12	1,26	0,83	0,53	0,34								
		hr				154	52,0	17,5	4,89	1,78	0,60	0,20								
18	300	v					3,98	2,55	1,51	1,00	0,64	0,41								
		hr					72,8	24,6	6,85	2,49	0,84	0,28								
24	400	v					5,31	3,40	2,01	1,33	0,85	0,54	0,38							
		hr					124	41,8	11,66	4,24	1,43	0,48	0,20							
30	500	v					6,63	4,25	2,51	1,66	1,06	0,68	0,47							
		hr					187	63,2	17,6	6,41	2,16	0,73	0,30							
36	600	v					5,10	3,02	1,99	1,27	0,82	0,57	0,42							
		hr					88,6	24,7	8,98	3,03	1,02	0,42	0,20							
42	700	v					5,94	3,52	2,32	1,49	0,95	0,66	0,49							
		hr					118	32,8	11,9	4,03	1,36	0,56	0,26							
48	800	v					6,79	4,02	2,65	1,70	1,09	0,75	0,55							
		hr					151	42,0	15,3	5,16	1,74	0,72	0,34							
54	900	v					7,64	4,52	2,99	1,91	1,22	0,85	0,62							
		hr					188	52,3	19,0	6,41	2,16	0,89	0,42							
60	1000	v					5,03	3,32	2,12	1,36	0,94	0,69	0,53							
		hr					63,5	23,1	7,79	2,63	1,08	0,51	0,27							
75	1250	v					6,28	4,15	2,65	1,70	1,18	0,87	0,66							
		hr					96,0	34,9	11,8	3,97	1,63	0,77	0,40							
90	1500	v					7,54	4,98	3,18	2,04	1,42	1,04	0,80							
		hr					134	48,9	16,5	5,57	2,29	1,08	0,56							
105	1750	v					8,79	5,81	3,72	2,38	1,65	1,21	0,93							
		hr					179	65,1	21,9	7,40	3,05	1,44	0,75							
120	2000	v					6,63	4,25	2,72	1,89	1,39	1,06	0,68							
		hr					83,3	28,1	9,48	3,90	1,84	0,96	0,32							
150	2500	v					8,29	5,31	3,40	2,36	1,73	1,33	0,85							
		hr					126	42,5	14,3	5,89	2,78	1,45	0,49							
180	3000	v							6,37	4,08	2,83	2,08	1,59	1,02						
		hr							59,5	20,1	8,26	3,90	2,03	0,69	0,28					
210	3500	v							7,43	4,76	3,30	2,43	1,86	1,19	0,83					
		hr							79,1	26,7	11,0	5,18	2,71	0,91	0,38					
240	4000	v							8,49	5,44	3,77	2,77	2,12	1,36	0,94					
		hr							101	34,2	14,1	6,64	3,46	1,17	0,48					
300	5000	v							6,79	4,72	3,47	2,65	1,70	1,18						
		hr							51,6	21,2	10,0	5,23	1,77	0,73						
360	6000	v							8,15	5,66	4,16	3,18	2,04	1,42						
		hr							72,3	29,8	14,1	7,33	2,47	1,02						
420	7000	v								6,61	4,85	3,72	2,38	1,65	1,21					
		hr								39,6	18,7	9,75	3,29	1,35	0,64					
480	8000	v								7,55	5,55	4,25	2,72	1,89	1,39					
		hr								50,7	23,9	12,49	4,21	1,73	0,82					
540	9000	v								8,49	6,24	4,78	3,06	2,12	1,56	1,19				
		hr								63,0	29,8	15,5	5,24	2,16	1,02	0,53				
600	10000	v								6,93	5,31	3,40	2,36	1,73	1,33					

FLOW RESISTANCE IN BENDS, VALVES AND GATES IN cm OF COLUMN OF WATER

WATER SPEED m/sec	SHARP BENDS 					SMOOTH BENDS 					STANDARD GATE VALVES	FOOT VALVES	CHECK VALVES
	a = 30°	a = 40°	a = 60°	a = 80°	a = 90°	d/R = 0,4	d/R = 0,6	d/R = 0,8	d/R = 1	d/R = 1,5			
0,1	0,03	0,04	0,05	0,07	0,08	0,007	0,008	0,01	0,0155	0,027	0,03	30	30
0,15	0,06	0,07	0,1	0,14	0,17	0,016	0,019	0,024	0,033	0,06	0,033	31	31
0,2	0,11	0,13	0,18	0,26	0,31	0,028	0,033	0,04	0,058	0,11	0,058	31	31
0,25	0,17	0,21	0,28	0,4	0,48	0,044	0,052	0,063	0,091	0,17	0,09	31	31
0,3	0,25	0,3	0,41	0,6	0,7	0,063	0,074	0,09	0,13	0,25	0,13	31	31
0,35	0,33	0,4	0,54	0,8	0,93	0,085	0,1	0,12	0,18	0,33	0,18	31	31
0,4	0,43	0,52	0,71	1	1,2	0,11	0,13	0,16	0,23	0,43	0,23	32	31
0,5	0,67	0,81	1,1	1,6	1,9	0,18	0,21	0,26	0,37	0,67	0,37	33	32
0,6	0,97	1,2	1,6	2,3	2,8	0,25	0,29	0,36	0,52	0,97	0,52	34	32
0,7	1,35	1,65	2,2	3,2	3,9	0,34	0,4	0,48	0,7	1,35	0,7	35	32
0,8	1,7	2,1	2,8	4	4,8	0,45	0,53	0,64	0,93	1,7	0,95	36	33
0,9	2,2	2,7	3,6	5,2	6,2	0,57	0,67	0,82	1,18	2,2	1,2	37	34
1	2,7	3,3	4,5	6,4	7,6	0,7	0,82	1	1,45	2,7	1,45	38	35
1,5	6	7,3	10	14	17	1,6	1,9	2,3	3,3	6	3,3	47	40
2	11	14	18	26	31	2,8	3,3	4	5,8	11	5,8	61	48
2,5	17	21	28	40	48	4,4	5,2	6,3	9,1	17	9,1	78	58
3	25	30	41	60	70	6,3	7,4	9	13	25	13	100	71
3,5	33	40	55	78	93	8,5	10	12	18	33	18	123	85
4	43	52	70	100	120	11	13	16	23	42	23	150	100
4,5	55	67	90	130	160	14	21	26	37	55	37	190	120
5	67	82	110	160	190	18	29	36	52	67	52	220	140

1) Flow resistance in bends is due to the contraction of the liquid threads resulting from the change of direction: the development of the bends must therefore be included in the length of the pipeline.

perdite-en_a_ot

2) Flow resistance in valves and gates was determined on the basis of practical tests.

VOLUMETRIC CAPACITY

Litres per minute l/min	Cubic metres per hour m ³ /h	Cubic feet per hour ft ³ /h	Cubic feet per minute ft ³ /min	Imperial gallon per minute Imp. gal/min	U.S. gallon per minute US gal/min
1,000	0,0600	2,1189	0,0353	0,2200	0,2642
16,6667	1,0000	35,3147	0,5886	3,6662	4,4029
0,4719	0,0283	1,0000	0,0167	0,1038	0,1247
28,3168	1,6990	60,0000	1,0000	6,2288	7,4805
4,5461	0,2728	9,6326	0,1605	1,0000	1,2009
3,7854	0,2271	8,0208	0,1337	0,8327	1,0000

PRESSURE AND HEAD

Newton per square metre N/m ²	kilo Pascal kPa	bar bar	Pound force per square inch psi	Metre of water m H ₂ O	Millimetre of mercury mm Hg
1,0000	0,0010	1 x 10 ⁻⁵	1,45 x 10 ⁻⁴	1,02 x 10 ⁻⁴	0,0075
1 000,0000	1,0000	0,0100	0,1450	0,1020	7,5006
1 x 10 ⁵	100,0000	1,0000	14,5038	10,1972	750,0638
6 894,7570	6,8948	0,0689	1,0000	0,7031	51,7151
9 806,6500	9,8067	0,0981	1,4223	1,0000	73,5561
133,3220	0,1333	0,0013	0,0193	0,0136	1,0000

LENGTH

Millimetre mm	Centimetre cm	Metre m	Inch in	Foot ft	Yard yd
1,0000	0,1000	0,0010	0,0394	0,0033	0,0011
10,0000	1,0000	0,0100	0,3937	0,0328	0,0109
1 000,0000	100,0000	1,0000	39,3701	3,2808	1,0936
25,4000	2,5400	0,0254	1,0000	0,0833	0,0278
304,8000	30,4800	0,3048	12,0000	1,0000	0,3333
914,4000	91,4400	0,9144	36,0000	3,0000	1,0000

VOLUME

Cubic metre m ³	Litre L	Millilitre ml	Imperial gallon imp. gal.	U.S. gallon US gal.	Cubic foot ft ³
1,0000	1 000,0000	1 x 10 ⁶	219,9694	264,1720	35,3147
0,0010	1,0000	1 000,0000	0,2200	0,2642	0,0353
1 x 10 ⁻⁶	0,0010	1,0000	2,2 x 10 ⁻⁴	2,642 x 10 ⁻⁴	3,53 x 10 ⁻⁵
0,0045	4,5461	4 546,0870	1,0000	1,2009	0,1605
0,0038	3,7854	3 785,4120	0,8327	1,0000	0,1337
0,0283	28,3168	28 316,8466	6,2288	7,4805	1,0000

TEMPERATURE

Water	Kelvin K	Celsius °C	Fahrenheit °F	$^{\circ}\text{F} = ^{\circ}\text{C} \times \frac{9}{5} + 32$ $^{\circ}\text{C} = (^{\circ}\text{F} - 32) \times \frac{5}{9}$
icing	273,1500	0,0000	32,0000	
boiling	373,1500	100,0000	212,0000	

G-at_pp-en_b_sc

FURTHER PRODUCT SELECTION AND DOCUMENTATION Xylect

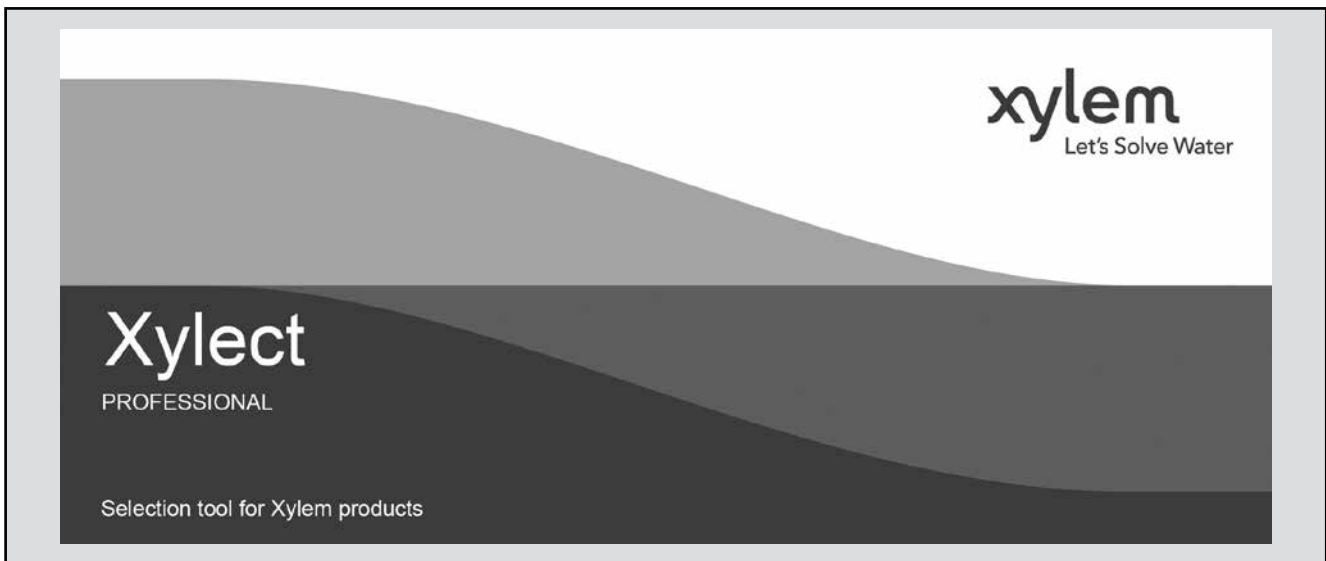

Xylect is pump solution selection software with an extensive online database of product information across the entire Lowara range of pumps and related products, with multiple search options and helpful project management facilities. The system holds up-to-date product information on thousands of products and accessories.

The possibility to search by applications and the detailed information output given makes it easy to make the optimal selection without having detailed knowledge about the Lowara products.

The search can be made by:

- Application
- Product type
- Duty point

Xylect gives a detailed output:

- List with search results
- Performance curves (flow, head, power, efficiency, NPSH)
- Motor data
- Dimensional drawings
- Options
- Data sheet printouts
- Document downloads incl dxf files

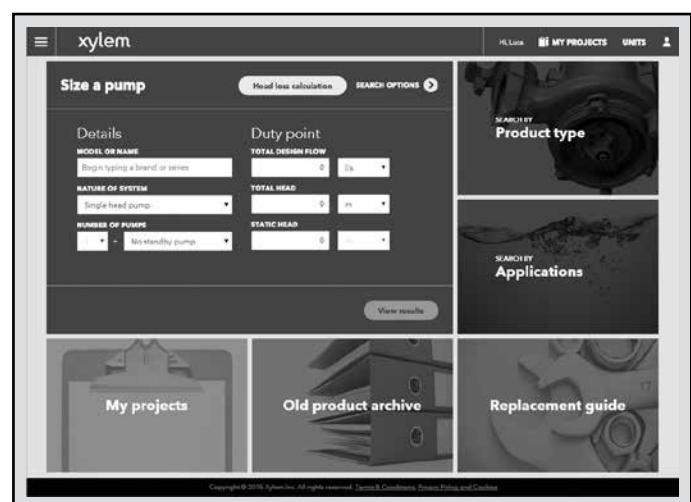

The search by application guides users not familiar with the product range to the right choice.

FURTHER PRODUCT SELECTION AND DOCUMENTATION

Xylect



The detailed output makes it easy to select the optimal pump from the given alternatives.

The best way to work with Xylect is to create a personal account. This makes it possible to:

- Set own standard units
- Create and save projects
- Share projects with other Xylect users

Every registered user has a proper space, where all projects are saved.

For more information about Xylect please contact our sales network or visit www.xylect.com.

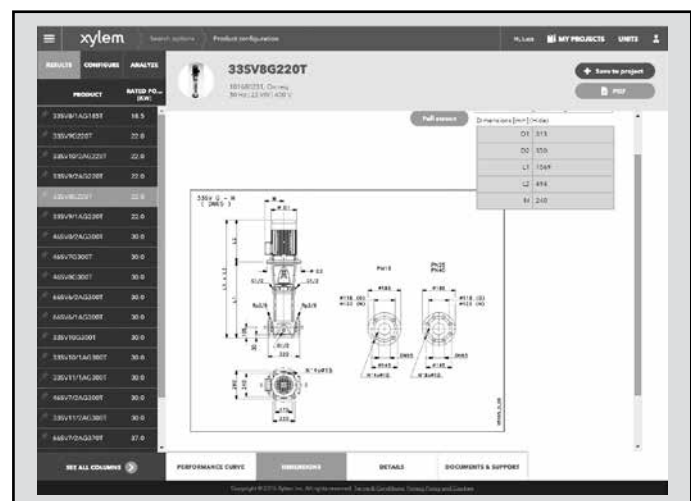

Xylem |'zīləm|

- 1) The tissue in plants that brings water upward from the roots;
- 2) a leading global water technology company.

We're a global team unified in a common purpose: creating advanced technology solutions to the world's water challenges. Developing new technologies that will improve the way water is used, conserved, and re-used in the future is central to our work. Our products and services move, treat, analyze, monitor and return water to the environment, in public utility, industrial, residential and commercial building services, and agricultural settings. With its October 2016 acquisition of Sensus, Xylem added smart metering, network technologies and advanced data analytics for water, gas and electric utilities to its portfolio of solutions. In more than 150 countries, we have strong, long-standing relationships with customers who know us for our powerful combination of leading product brands and applications expertise with a strong focus on developing comprehensive, sustainable solutions.

For more information on how Xylem can help you, go to www.xylem.com.



For information and technical support
Xylem Service Italia Srl

Via Dottor Vittorio Lombardi 14
36075 - Montecchio Maggiore (VI) - Italy
Tel. (+39) 0444 707111
Fax (+39) 0444 491043
www.lowara.com

Xylem Service Italia Srl reserves the right to make modification without prior notice.
Lowara, Xylem are trademarks of Xylem Inc. or one of its subsidiaries
© 2018 Xylem, Inc.