

KME-V SERIES (50 Hz)

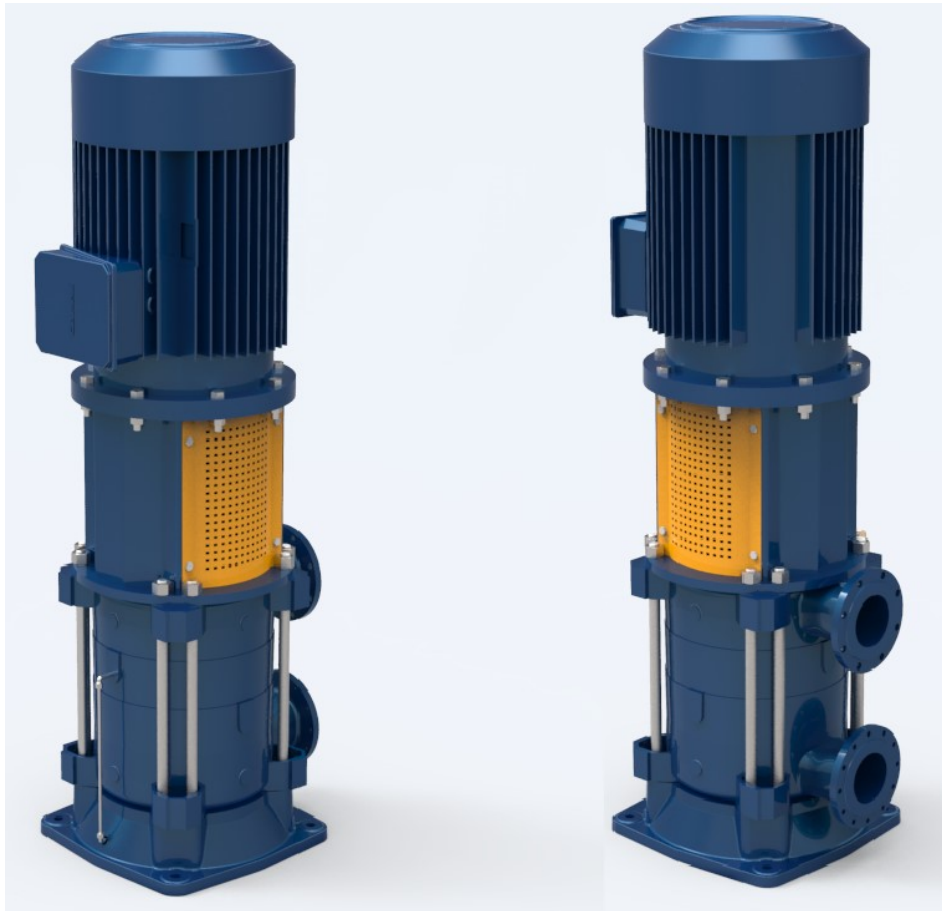

TECHNICAL MANUAL



KME-V Series

High Pressure Multistage Centrifugal Pumps

General Specifications



Mas Grup

Fields of Application

For pumping of clear and slightly contaminated liquids in:

- Water supply systems,
- Booster sets in high rise buildings and industry,
- Water treatment,
- Industrial washdown systems,
- Fire extinguishing plants,
- Boiler feed and condensate transfer,
- Sanitary and cleaning installations,
- For industrial applications and public services,
- Water distribution services,
- Industrial applications,
- Shipbuilding, Mining, Power Stations, Filter Units,
- Irrigation plants,
- Central heating systems.

Pumped Liquids

Thin, clean, non-aggressive and non-explosive liquids free from solid particles and fibres.

- Fresh water, potable water, boiler feed water, industrial water, sea and brackish water, hot water, condensate, lyes, etc.

For special applications, please consult to MAS DAF MAKINA SAN. A.Ş.

Design

- The KME-V Pump is a vertical axis, radially split, ring section design multistage centrifugal pump of non-self priming type.
- Impellers are between bearings, single entry, closed type and dynamically balanced. Impeller diameter will be corrected for optimal adherence to the required duty point.
- For balancing the axial thrust, all impellers have back wear rings. For high pressure, balance disc application is used.
- The pump series consists of 2 sizes. KME 100 and 125. Stages are from 2 up to max. 7 stages.
- Pump and motor are connected to each other via flexible coupling.
- Normally, discharge part is at motor side and suction part is at dead end side.
- Suction and discharge nozzles may be a choice of three 90° positions. By special request, it is possible to put the suction nozzle at the motor side. In this arrangement pump and motor rotation must be counter clockwise.

Shaft

Chromium steel (AISI 420) fine grained shafts are used on KME-V pumps. There is no big diameter difference along the shaft and it is possible and very easy to dismantling the pump beginning from suction or discharge ends.

Bearings

- At the discharge side of the pump, double row angular contact ball bearings are used (3300 Series).
- The bearings are lubricated with grease.
- Deflectors and lip seals on the shaft prevent leakage fluid from getting into bracket.

Shaft Seal

- Pumps are supplied as standard, conventional packed glands.
- Lantern rings are used on both sides for water sealing.
- At the sealing section of the pump, shaft is protected by hard chromium plated sleeves.
- On the discharge side, special high pressure packing and bushes for dropping pressure are used.
- Uncooled stuffing box is standard (Up to 90 °C).
- Uncooled mechanical seal is optional (Up to 90 °C).
- Water cooled stuffing box or mechanical seal is optional (90 °C - 140 °C).
- Double-acting and cartridge seals are upon request.

Technical Data

Suction Flange	: DN 125...DN 150 (PN 16)
Discharge Flange	: DN 100...DN 125 (PN 40)
Operating Pressure	: 40 Bar (Maximum)
Speed	: 1450 -1750 rpm
No of Stages	: 2 – 7
Capacity Range	: 30 - 300 m ³ / h
Head Range	: 30 - 190 m

Identification Code for Pump

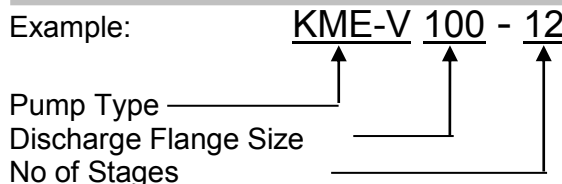

KME-V Series

High Pressure Multistage Centrifugal Pumps

Cross-Sectional Drawing For KME-V



Mas Grup

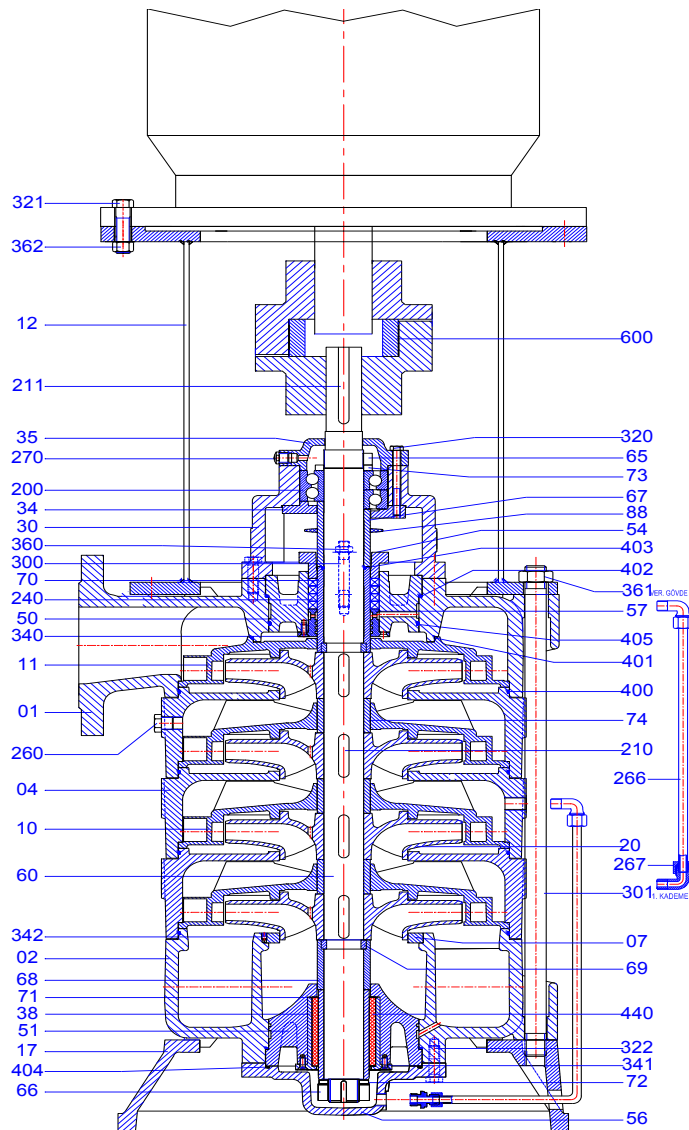

PART LIST

Part No	Part Name	Part No	Part Name	Part No	Part Name
01	Discharge Casing	65	Shaft Nut	360	Gland Nut
02	Suction Casing	66	Shaft Nut	361	Nut
04	Middle Stage	67	Spacer Bush (Discharge)	362	Nut
07	Wearing Ring	68	Spacer Bush (Suction)	300	Gland Stud
10	Diffuser	69	Clipping Spacer Bush	301	Puller Stud
11	Last Stage Diffuser	70	Seal Bushing (Discharge)	320	Hexagon Bolt
12	Adaptor	71	Carbon Bushing	321	Hexagon Bolt
17	Base Plate	72	Spacer Washer	322	Hexagon Bolt
20	Impeller	73	Spacer Washer	340	Countersunk Bolt
30	Bearing Housing	74	Impeller Spacer Bushing	341	Countersunk Bolt
34	Bearing Cover (Inner)	88	Thrower Ring	342	Setuskur
35	Bearing Cover (Outer)	200	Bearing	400	O-Ring
38	Carbon Bushing	210	Key	401	O-Ring
50	Stuffing Box (Discharge)	211	Coupling Key	402	O-Ring
51	Stuffing Box (Suction)	260	Plug	403	O-Ring
54	Gland	266	Irrigation Pipe	404	O-Ring
56	Bottom Cover	267	Angle Union	405	O-Ring
57	Lantern Ring	240	Soft Packing	440	Carbon
60	Pump Shaft	270	Grease Nipple	600	Coupling

KME-V Series

High Pressure Multistage Centrifugal Pumps

Technical Data



Mas Grup

Material Options

Components	Material. No						
		0.6025 GG 25	0.7040 GG 40	2.1050.01 Bronze	1.4021 AISI 420	1.4301 AISI 304	1.4401 AISI 316
Suction & Discharge Casing		●	○	○		○	○
Stage Casing		●	○	○		○	○
Impeller		●	○	○		○	○
Diffuser		●	○	○		○	○
Gland			○	●		○	○
Pump Shaft					●	○	○
Shaft Sleeve					●	○	○
Stuffing Box		●	○	○		○	○
Bearing Housing		●	○				
Bearing Cover		●	○				

- – Standard Manufacturing
- – Optional

Material Equivalent

Description	DIN 17007	EN-DIN	ASTM
Cast Iron	0.6025	GJL-250 (GG25)	A 48 Class 40-B
Nodular Cast Iron	0.7040	GJS-400-15 (GGG40)	A 536 Gr.60-40-18
Cast Bronze	2.1050.01	G-Cu Sn 10	B 584 C 90700
Chrome Steel	1.4021	X20 Cr 13	A 276 Type 420
Chrome Nickel Steel	1.4301	X5 Cr Ni 18.9	A 276 Type 304
Chrome Nickel Molybdenum Steel	1.4401	X5 Cr Ni Mo 18.10	A 276 Type 316

Number of Stages

Model Designation	Min. Number of Stages	Max. Number of Stages of Speed r.p.m.	
		1450	2900
KME-V 100	2	7	-
KME-V 125	2	5	-

Flange Dimensions

- Discharge Flanges : DIN 2533 – PN 40
- Suction Flanges : DIN 2533 – PN 16

PN 40 Flange Dimensions

DN mm ø	Df mm ø	T mm ø	Z EACH	ø mm ø	B mm
DN 100	235	190	8	22	28
DN 125	270	220	8	26	30
DN 150	300	250	8	26	34

KME-V Series

High Pressure Multistage Centrifugal Pumps

Technical Data



Mas Grup

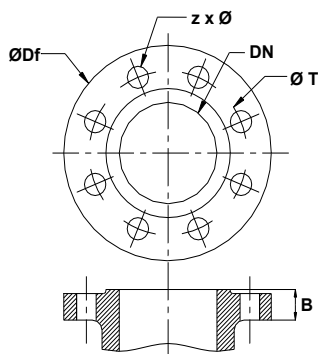

PN 16 Flange Dimensions

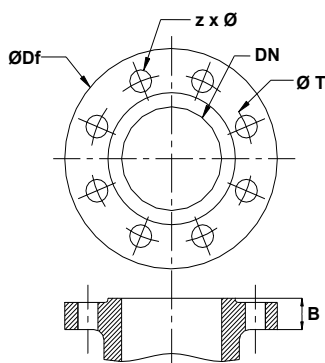

DN mm ø	Df mm ø	T mm ø	Z EACH	ø mm ø	B mm
DN 100	220	180	8	18	24
DN 125	250	210	8	18	26
DN 150	285	240	8	22	26

Pump Flange Classification

Pump Type	Flange			
	DNs (mm) (Suction)		DNd (mm) (Discharge)	
	KME-V 100	125	PN 16	100
KME-V 125	150	125		

Shaft End & Key Way Dimensions

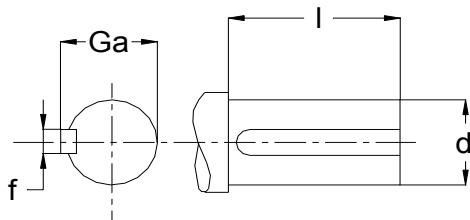

Pump Type	d mm ø	l mm	f mm	Ga mm
KME-V 100	40	110	12	43
KME-V 125	45	110	14	48.5

Casing Stud Dimensions

Pump Size	Qty.	Dimension
KME-V 100	8	M24
KME-V 125	8	M27

KME-V Series

High Pressure Multistage Centrifugal Pumps

Technical Data



Mas Grup

Bearings, Stuffing-Box for KME-V (Mechanical Seal & Soft Packing Design)

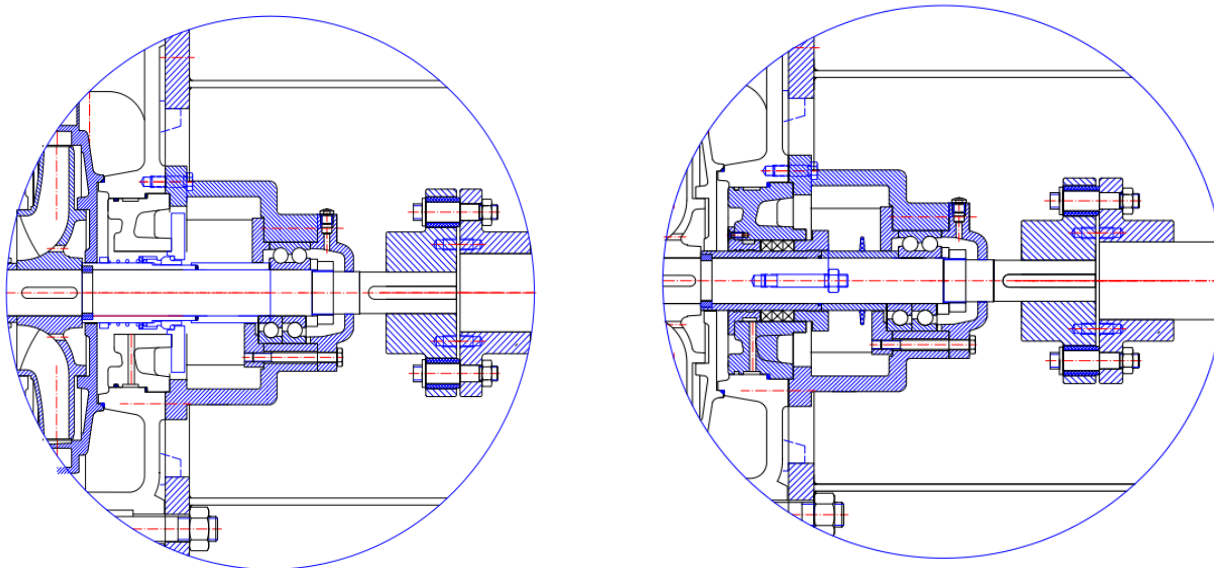

Pump Type	Bearing (Motor Side)	Bearing (Dead Side)	Soft Packing for Discharge Side (ØD1xØD2xBxL) (mm)	Shaft Diameter (mm)
KME-V 100	3309 45 X 100 X 39.7	Graphite Carbon Bearing Ø58 Ø72x90	4 Soft Packing x 1 Lantern Ring 80 x 60 x 10 x 70	Ø40
KME-V 125	3310 50 X 110 X 44.4	Graphite Carbon Bearing Ø58 Ø72x90	3 Soft Packing x 1 Lantern Ring 89 x 65 x 12 x 64	Ø45

Mechanical Seal Applications

Pump Type	For Hm<100 mwc		For Hm>100mwc	
	Mech. Seal Dia. Suction	Mech. Seal Dia. Discharge	Mech. Seal Dia. Suction	Mech. Seal Dia. Discharge
KME 100	Ø60	Ø60	Ø60	Ø60
KME 125	Ø65	Ø65	Ø65	Ø60

Different Mounting Arrangements for KME-V

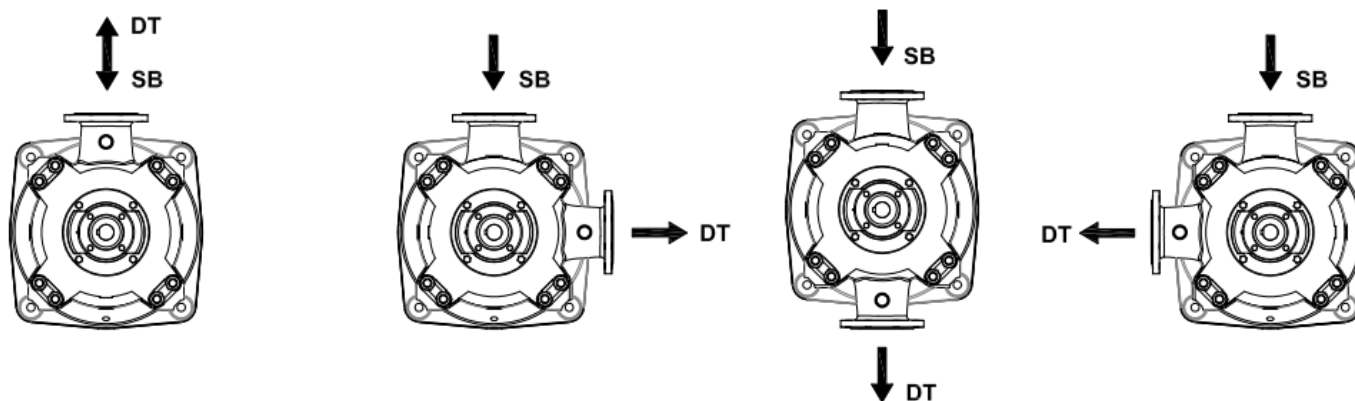

SB : Emme Altta (Suction Bottom)

DT : Basma Üstte (Discharge Top)

BURGMANN MG1

- Single Seal
- Unbalanced
- Elastomer Bellows
- Independent on direction of rotation

p ₁	: 12 Bar
t	: -20...120 °C
V _g	: 10 m/s

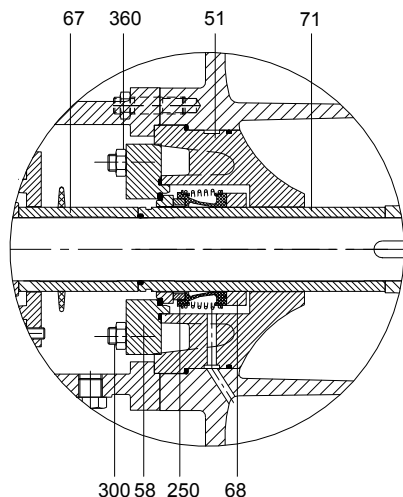

Part List

51	Stuffing Box
58	Mech. Seal Cover
67	Space Sleeve
68	Mech. Seal Front Sleeve
71	Seal Sleeve
250	Mechanical Seal
300	Mech. Seal Cover Stud
360	Mech. Seal Cover Nut

BURGMANN HJ977GN

- Single Seal
- Balanced
- Spring, product protected
- Independent on direction of rotation

p ₁	: 25 Bar
t	: -20...180 °C
V _g	: 10 m/s

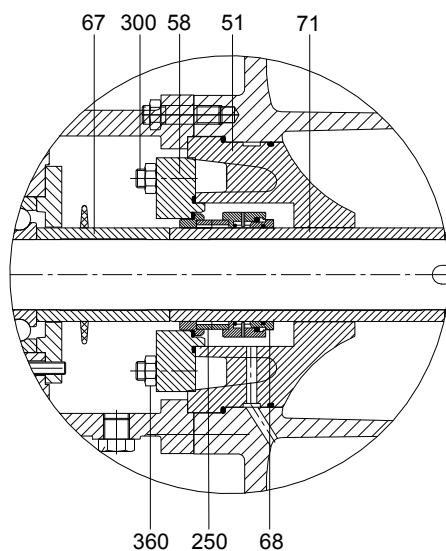

Part List

51	Stuffing Box
58	Mech. Seal Cover
67	Space Sleeve
68	Mech. Seal Front Sleeve
71	Seal Sleeve
250	Mechanical Seal
300	Mech. Seal Cover Stud
360	Mech. Seal Cover Nut

KME-V Series

High Pressure Multistage Centrifugal Pumps

Mechanical Seal Applications



Mas Grup

BURGMANN M3N

- Single Seal
- Unbalanced
- Conical Spring
- Dependent on direction of rotation

p ₁	: 10 Bar
t	: -20...180 °C
V _g	: 10 m/s

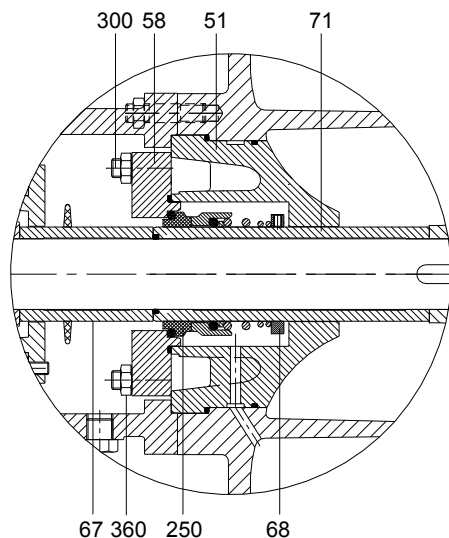

Part List

51	Stuffing Box
67	Space Sleeve
68	Mech. Seal Front Sleeve
71	Seal Sleeve
250	Mechanical Seal
300	Mech. Seal Cover Stud
360	Mech. Seal Cover Nut

BURGMANN H12N

- Single Seal
- Balanced
- Conical Spring
- Dependent on direction of rotation

p ₁	: 25 Bar
t	: -20...220 °C
V _g	: 15 m/s

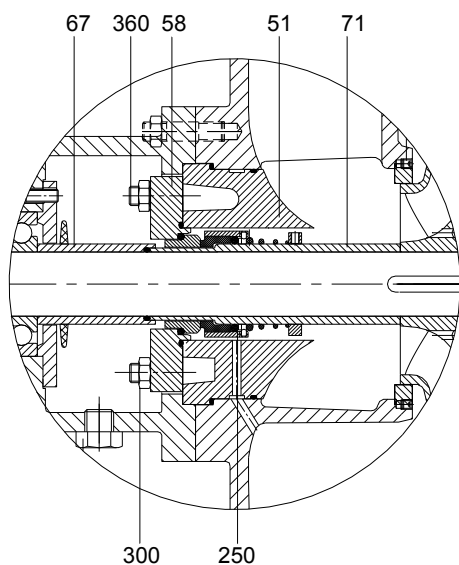

Part List

51	Stuffing Box
67	Space Sleeve
68	Mech. Seal Front Sleeve
71	Seal Sleeve
250	Mechanical Seal
300	Mech. Seal Cover Stud
360	Mech. Seal Cover Nut

KME-V Series

High Pressure Multistage Centrifugal Pumps

Pump Dimensions



Mas Grup

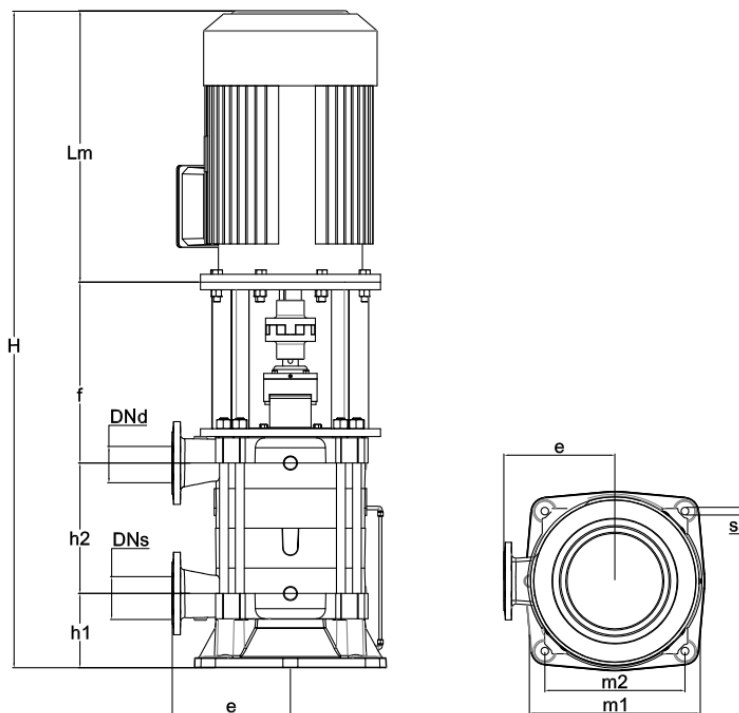

Pump Type	DN (suction)	DN (discharge)	h1	e	m1	m2	s(Ø)
KME-V 100	125	100	190	300	510	420	26
KME-V 125	150	125	246	375	610	480	26

"h2" dimension according to number of stage

Pump Type	2	3	4	5	6	7
KME-V 100	237	341	446	551	656	761
KME-V 125	281	409	537	665	-	-

"Lm" dimension according to motor power

	15	18.5	22	30	37	45	55	75	90	110	132	160
Lm	490	490	550	637	637	680	756	818	818	980	980	980

"f" dimension according to number of stage and motor power

Pump Type	2	3	4	5	6	7	kW
KME-V 100	516.5						15
KME-V 100	516.5	516.5					18.5
KME-V 100	516.5	516.5					22
KME-V 100		516.5	516.5	516.5			30
KME-V 100		546.5	546.5	546.5	546.5		37
KME-V 100			546.5	546.5	546.5	546.5	45
KME-V 100				546.5	546.5	546.5	55
KME-V 100					546.5	546.5	75

KME-V 125	576						37
KME-V 125	576						45
KME-V 125	576	576					55
KME-V 125	576	576	576				75
KME-V 125		576	576	576			90
KME-V 125		591	591	591			110
KME-V 125			591	591			132
KME-V 125				591			160

KME-V Series

High Pressure Multistage Centrifugal Pumps

Performance Curves

KME-V 100 / 2



Mas Grup

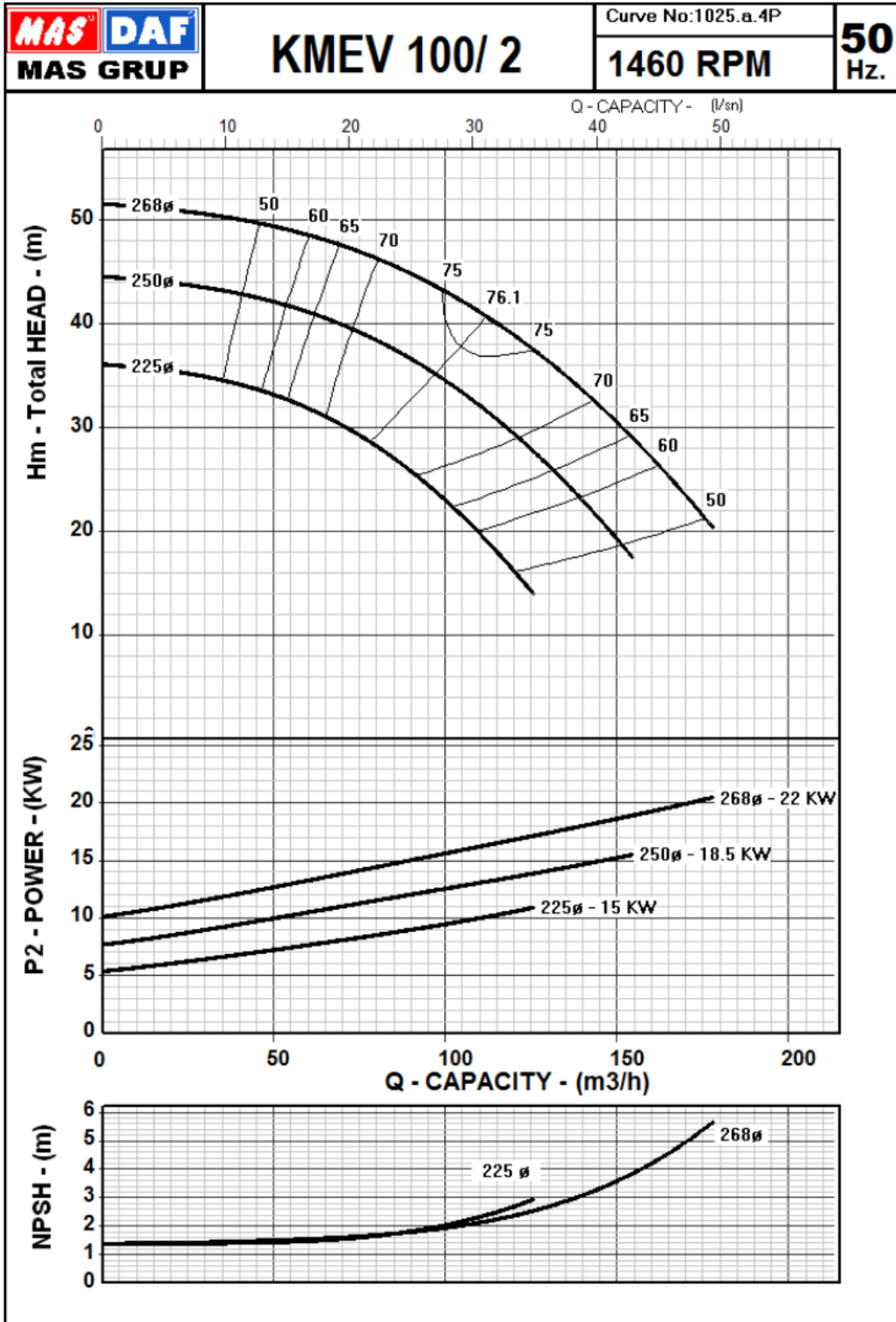

KME-V Series

High Pressure Multistage Centrifugal Pumps

Performance Curves

KME-V 100 / 3



Mas Grup

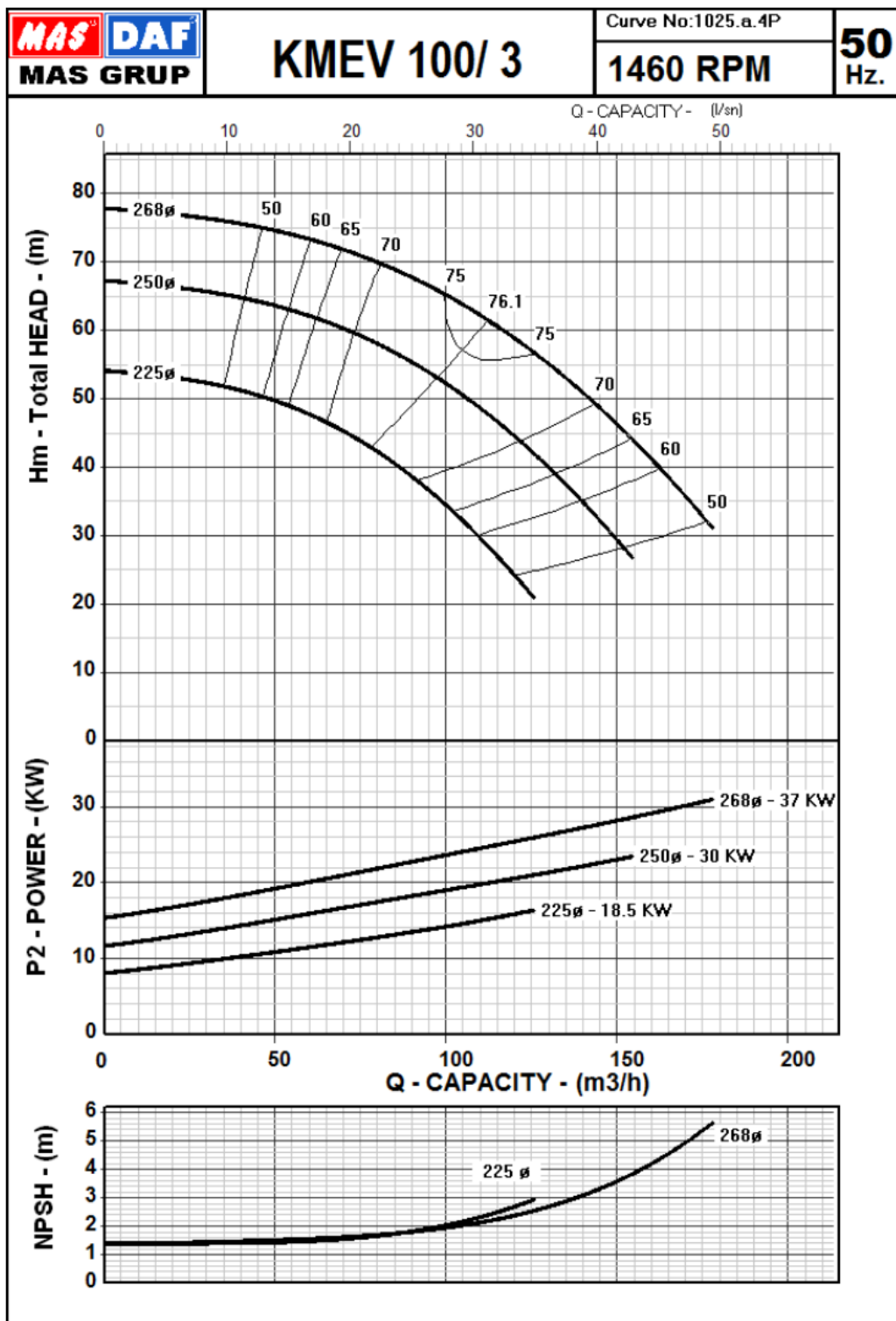

KME-V Series

High Pressure Multistage Centrifugal Pumps

Performance Curves

KME-V 100 / 4



Mas Grup

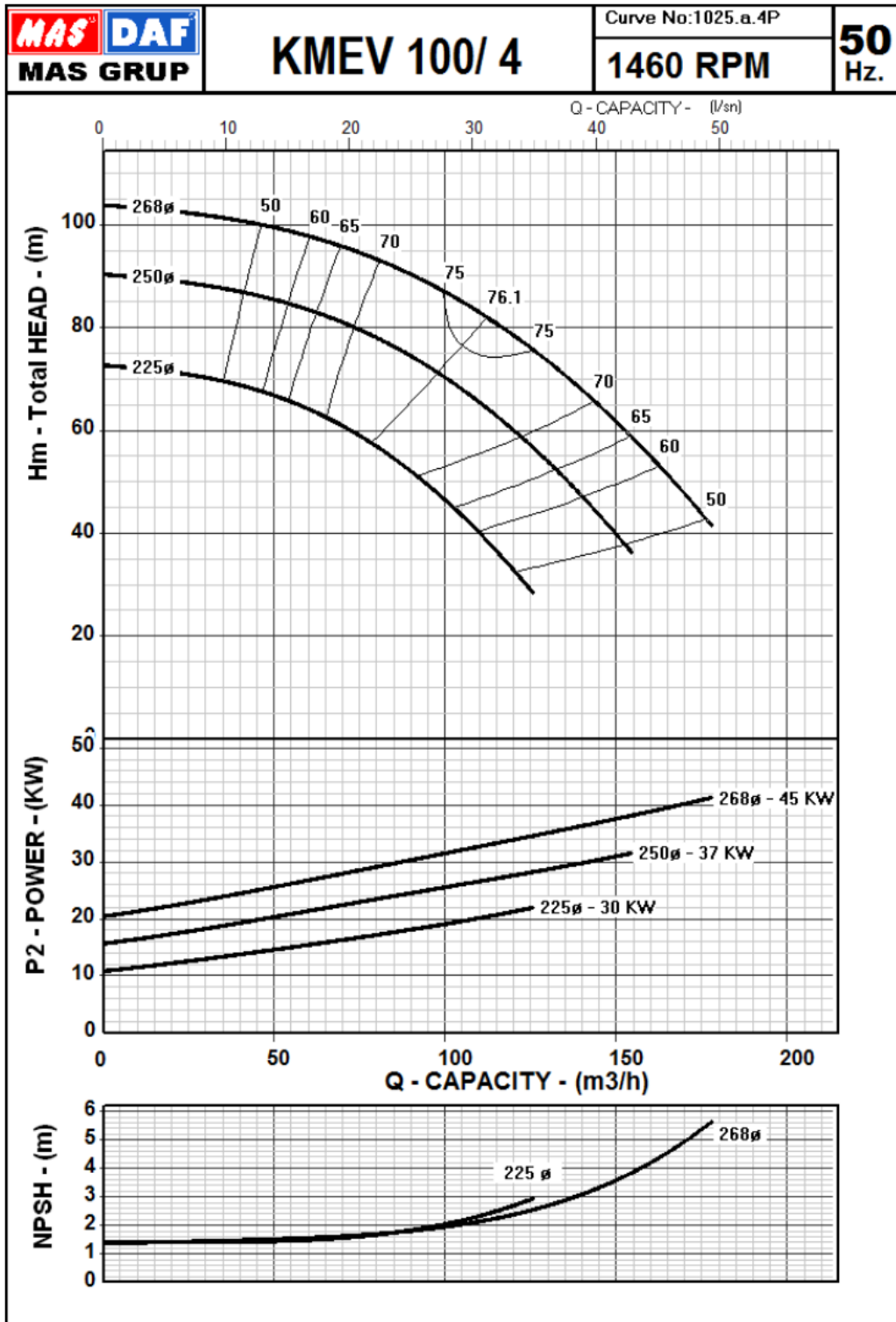

KME-V Series

High Pressure Multistage Centrifugal Pumps

Performance Curves

KME-V 100 / 5



Mas Grup

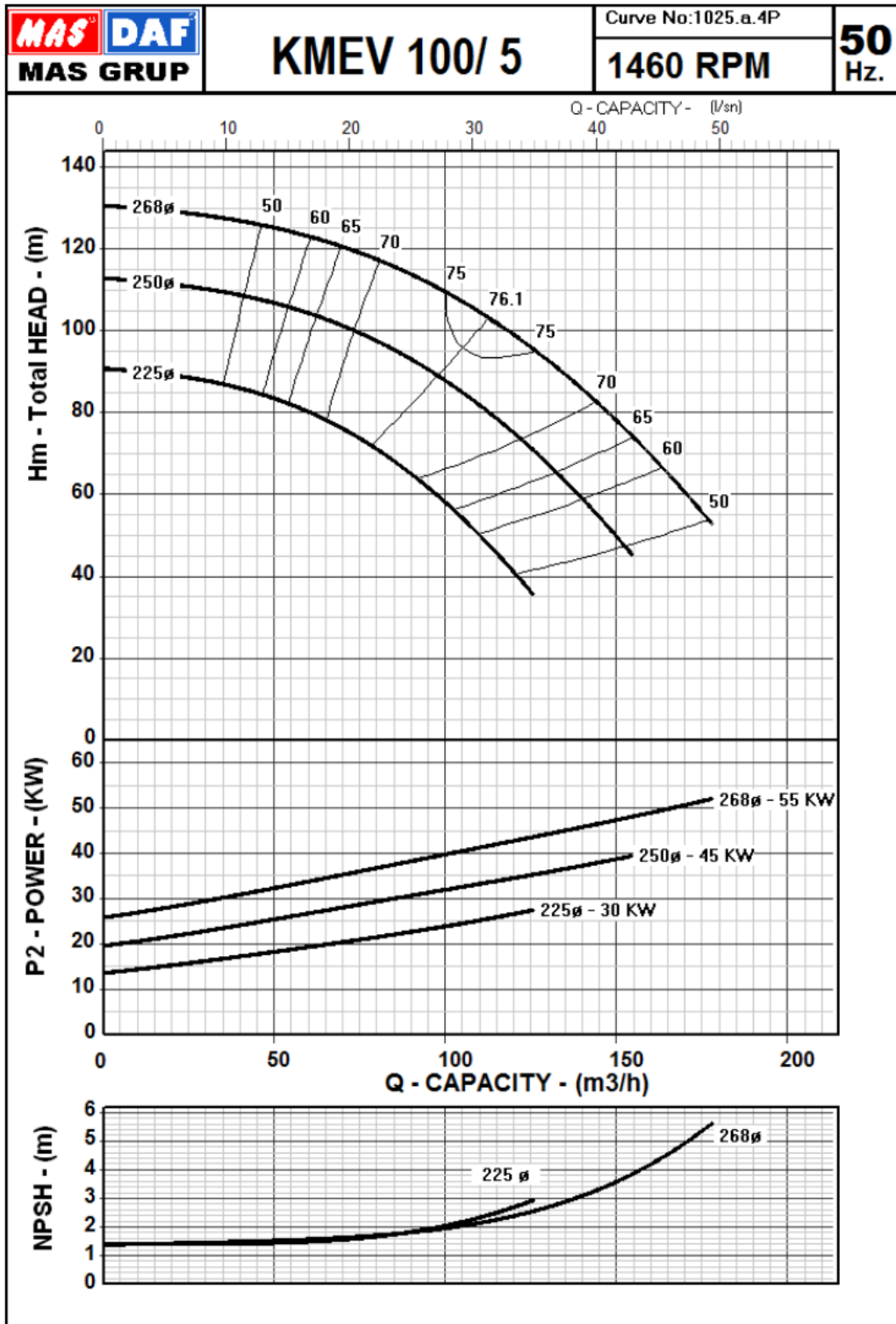

KME-V Series

High Pressure Multistage Centrifugal Pumps

Performance Curves

KME-V 100 / 6



Mas Grup

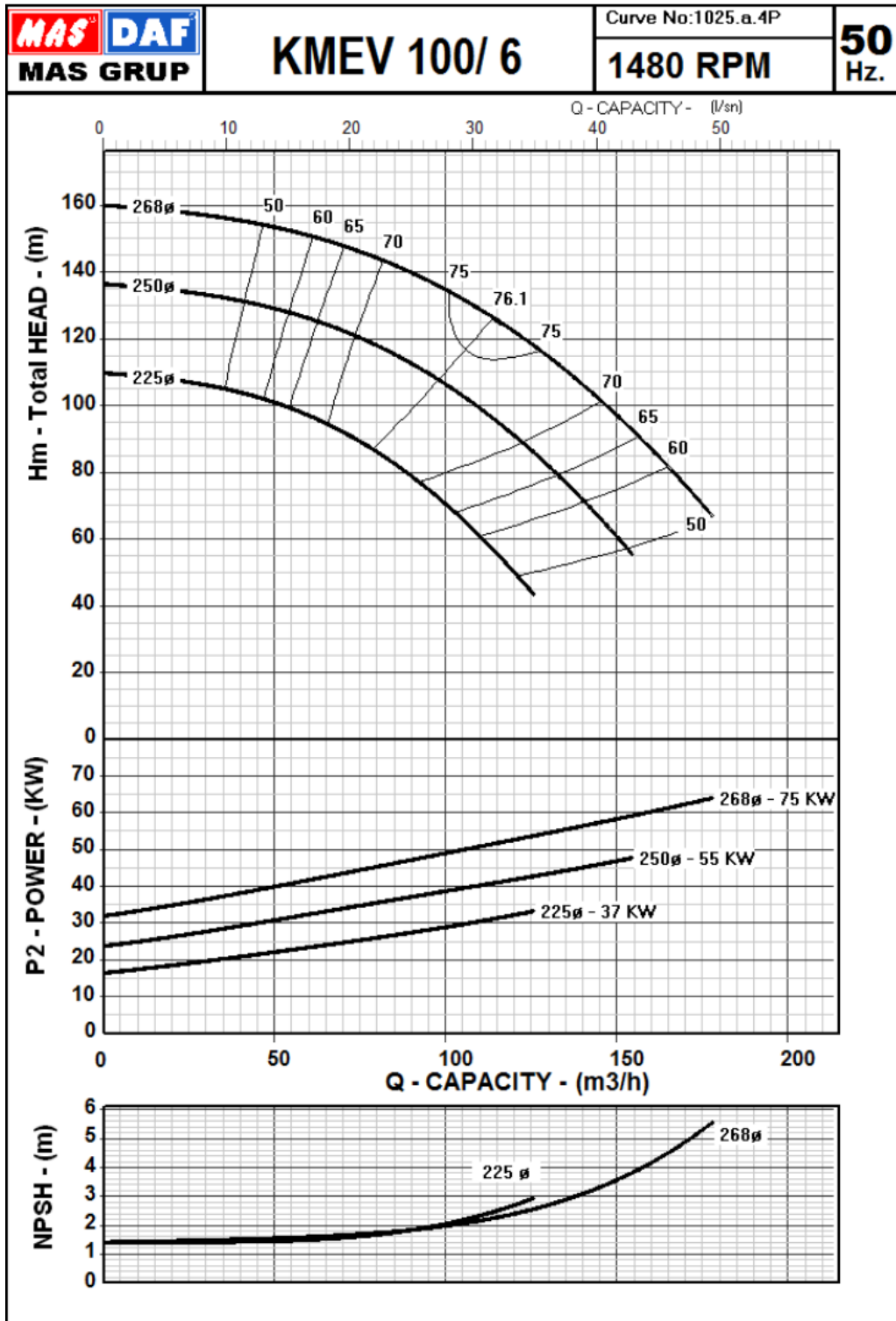

KME-V Series

High Pressure Multistage Centrifugal Pumps

Performance Curves

KME-V 100 / 7



Mas Grup

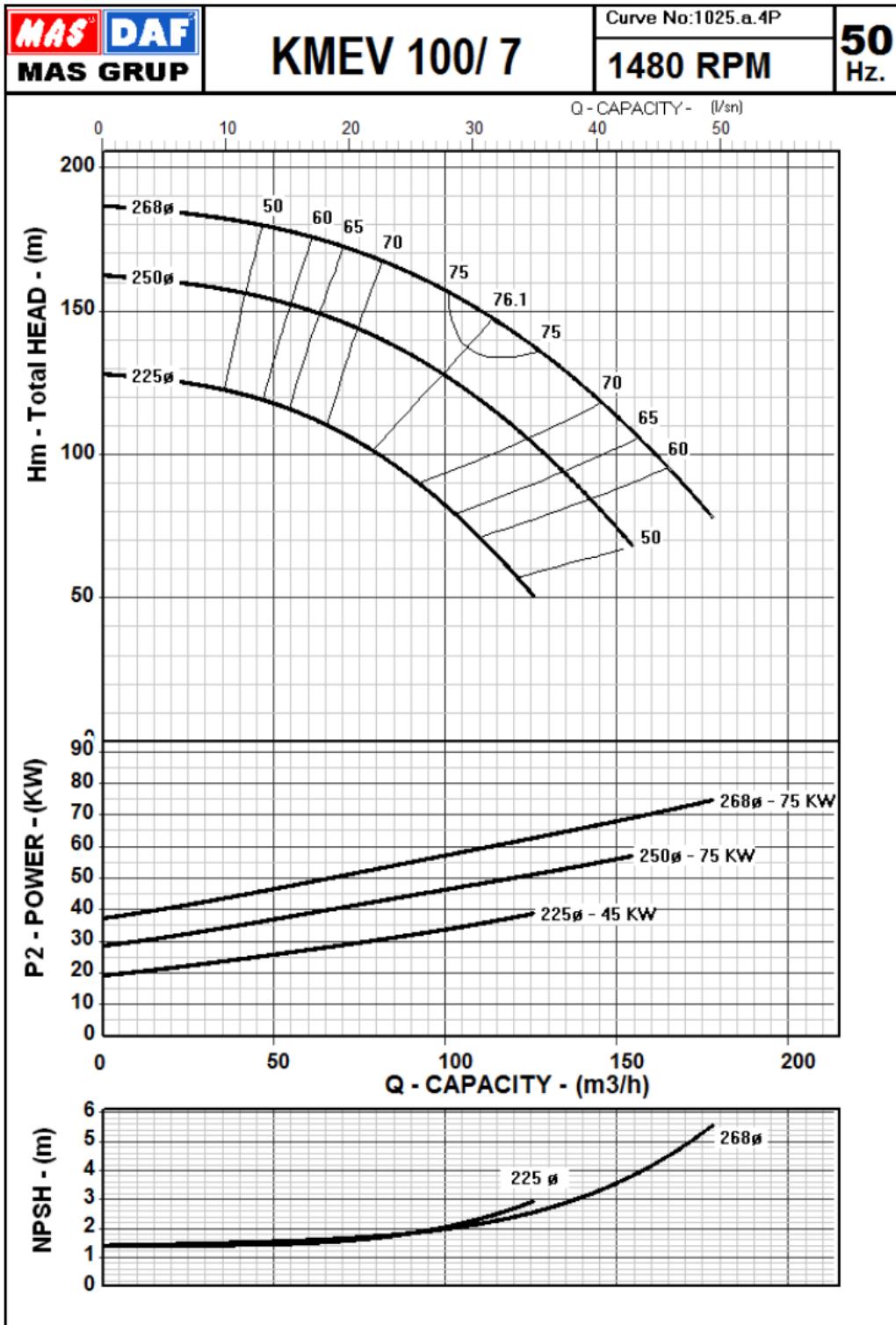

KME-V Series

High Pressure Multistage Centrifugal Pumps

Performance Curves

KME-V 125 / 2



Mas Grup

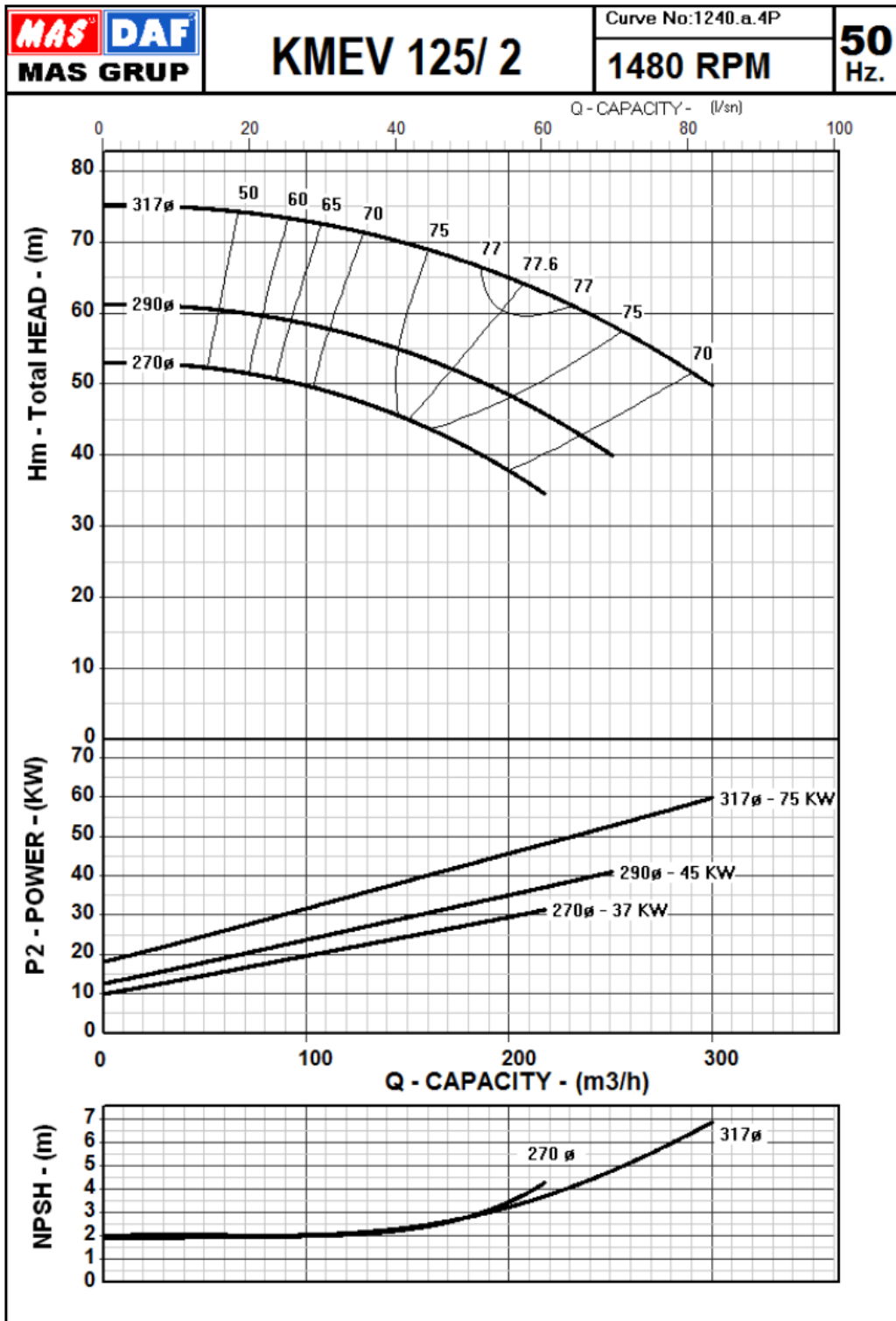

KME-V Series

High Pressure Multistage Centrifugal Pumps

Performance Curves

KME-V 125 / 3



Mas Grup

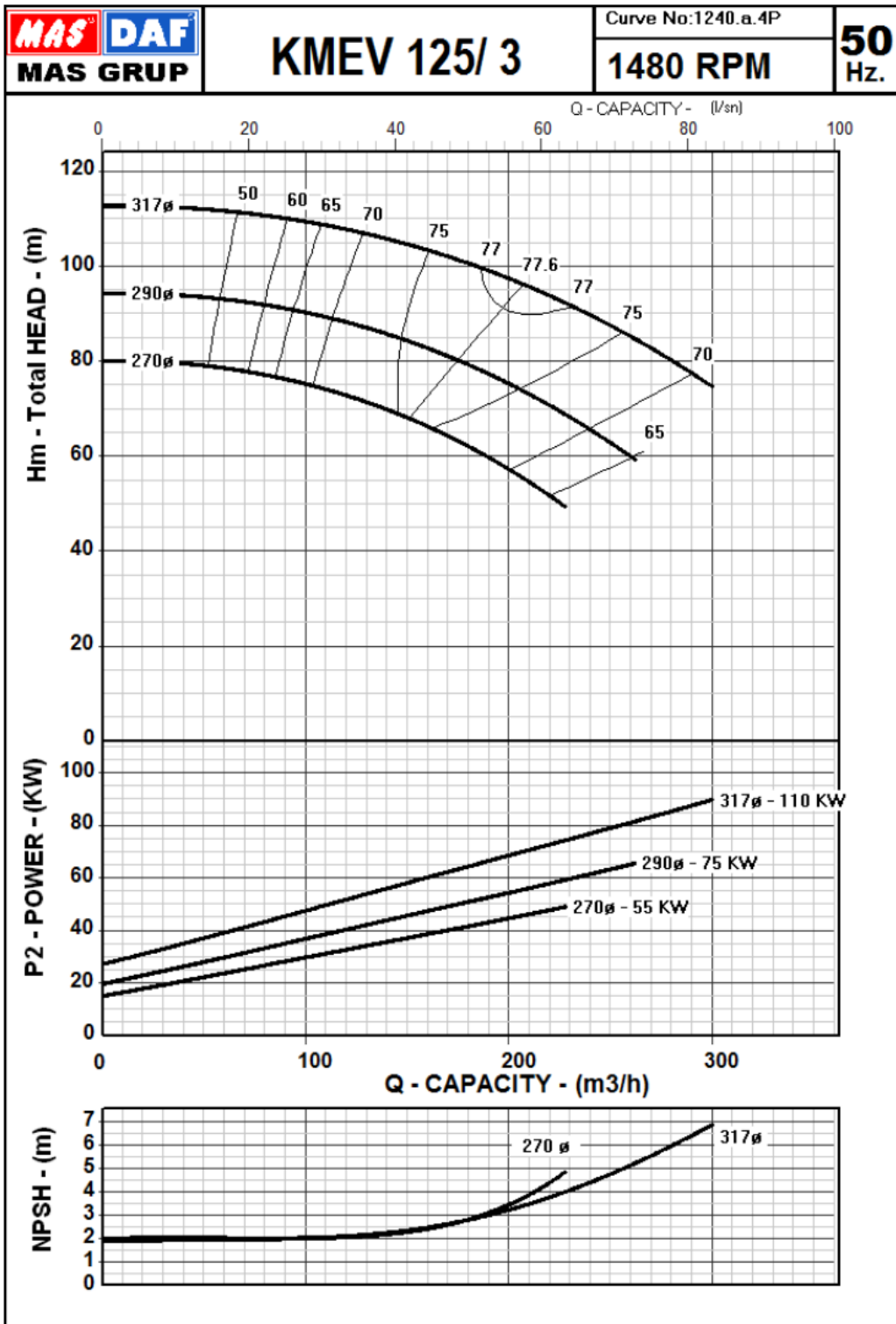

KME-V Series

High Pressure Multistage Centrifugal Pumps

Performance Curves

KME-V 125 / 4



Mas Grup

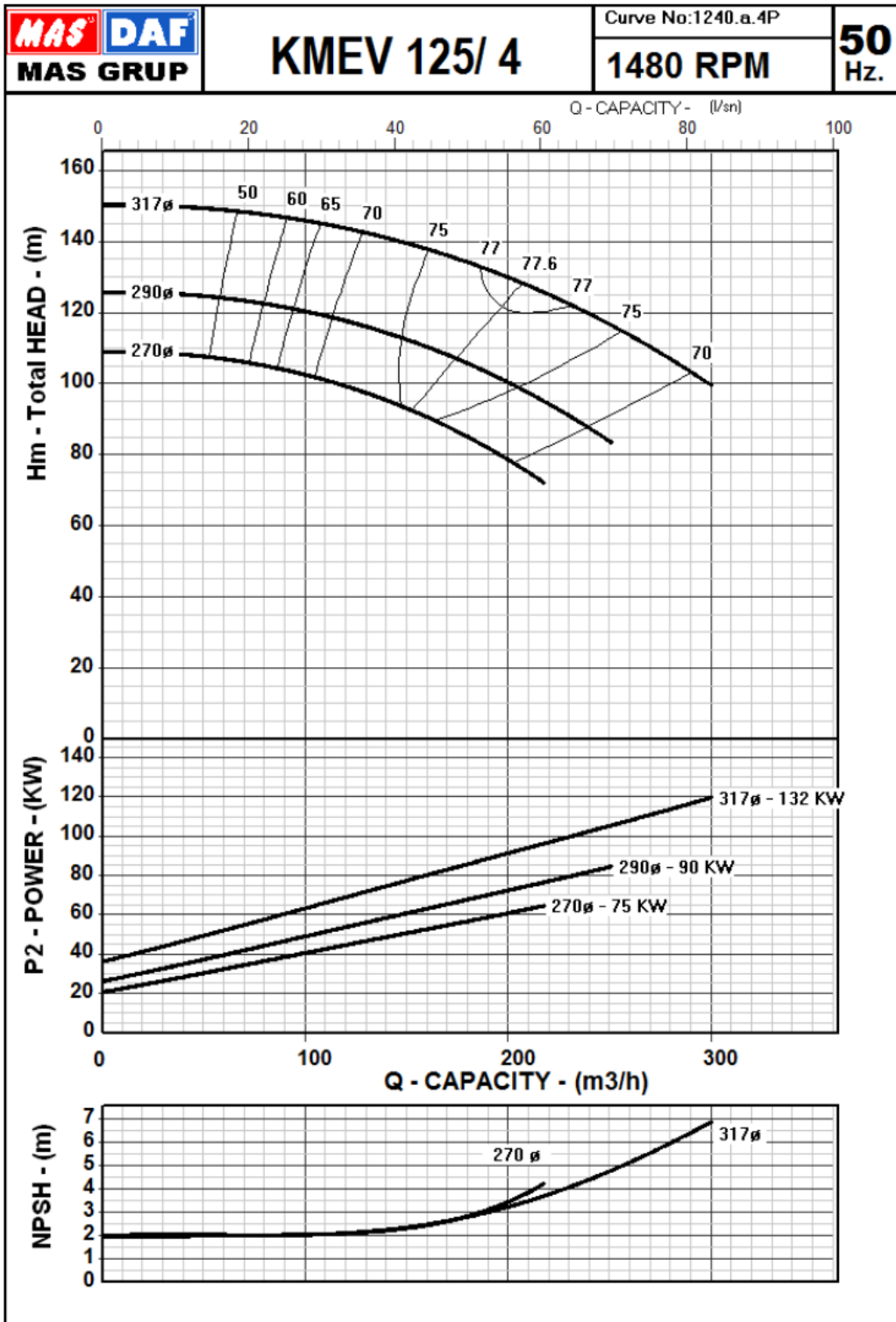

KME-V Series

High Pressure Multistage Centrifugal Pumps

Performance Curves

KME-V 125 / 5



Mas Grup

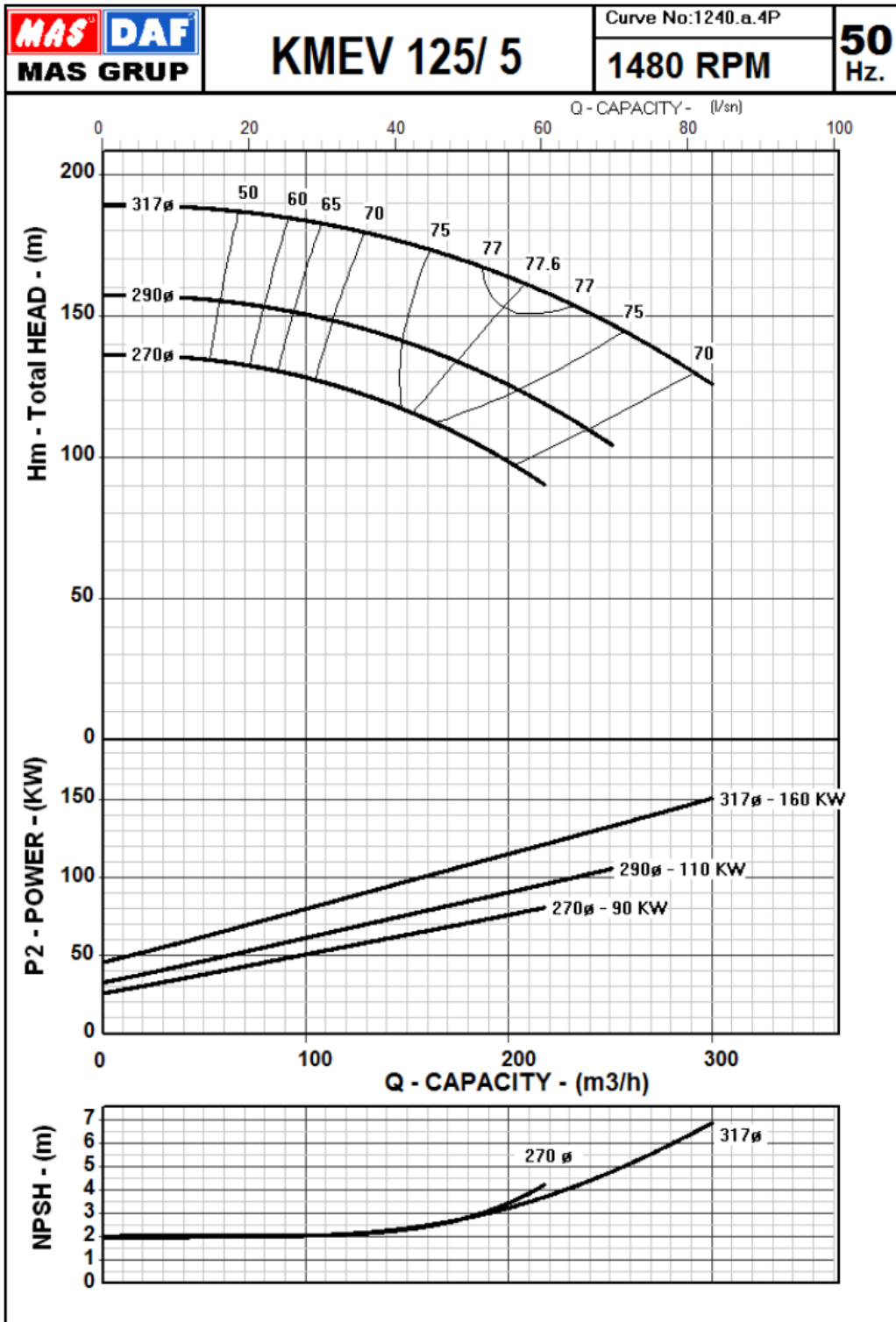

KME-V Series
 High Pressure Multistage Centrifugal Pumps
Exploded View



Mas Grup

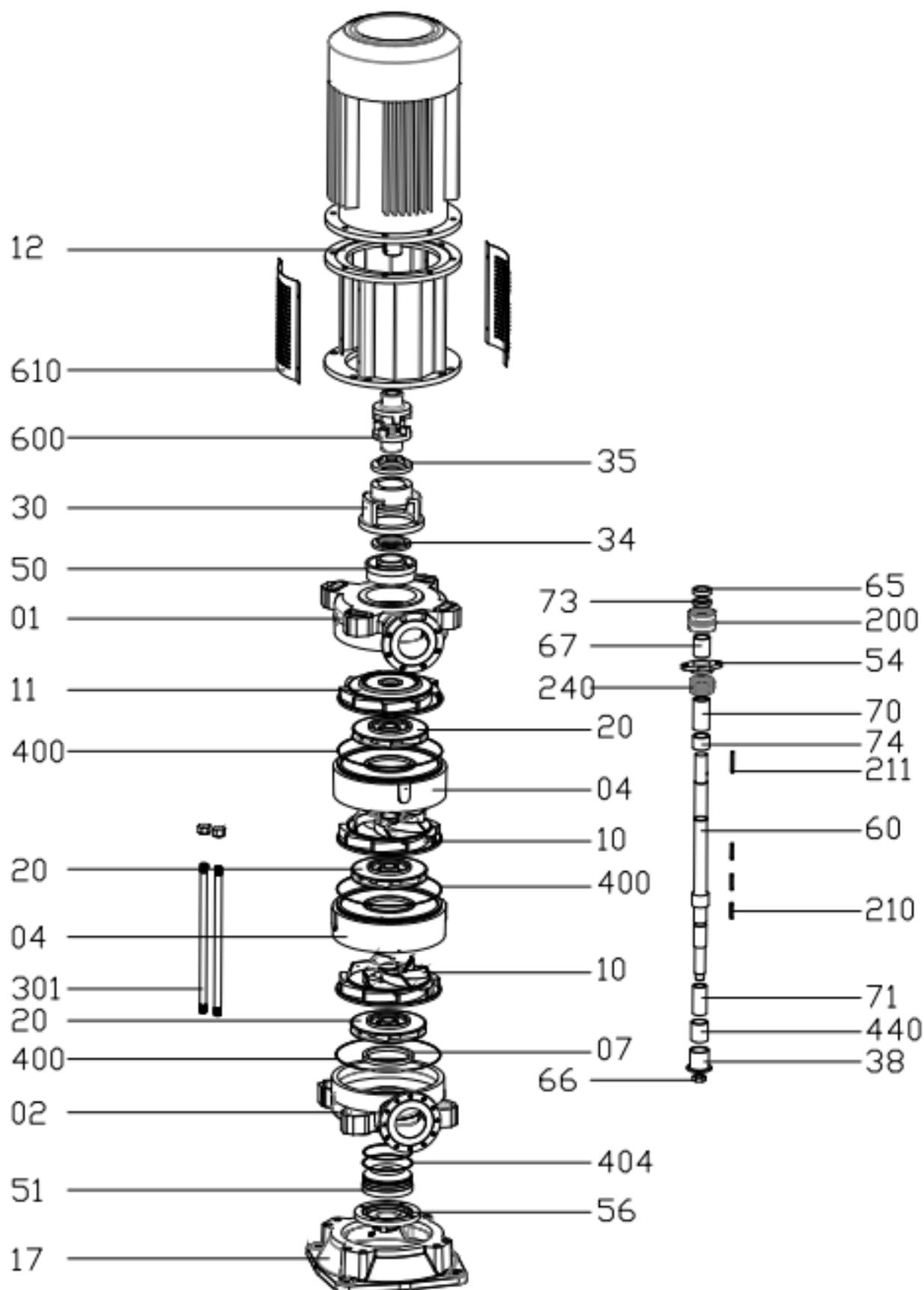

KME-V Series

High Pressure Multistage Centrifugal Pumps

Part List



Mas Grup

Part No	Part Name	Part No	Part Name
01	Discharge Casing	65	Shaft Nut (Disc.)
02	Suction Casing	66	Shaft Nut (Suc.)
04	Stage Casing	67	Spacer Sleeve (Disc.)
07	Impeller Wearing Ring	70	Seal Sleeve (Disc.)
10	Diffuser	71	Carbon Bearing Bushing
11	Last Stage Diffuser	73	Bearing Presser Sleeve
12	Adapter	74	Impeller Spacer Sleeve
17	Baseplate	200	Bearing
20	Impeller	210	Impeller Key
30	Bearing Housing	211	Coupling Key
34	Bearing Cover (Inner)	240	Seal
35	Bearing Cover (Outer, Disc.)	301	Stud
38	Carbon Bearing Sleeve	400	O-Ring (Stage Casing)
50	Stuffing Box (Disc.)	404	O-Ring (Bottom Bearing)
51	Stuffing Box (Suc.)	440	Carbon Bearing
54	Gland	600	Coupling Kit
56	Bottom Cover	610	Cover Plate
60	Shaft		



Mas Grup

Head Office / Center Service:

Aydınlı Mah. Birlik OSB. 1.No'lu Cadde No:17 Tuzla - İSTANBUL / TÜRKİYE
Tel: +90 (216) 456 47 00 pbx Fax: +90 (216) 455 14 24

Ankara Regional Directorate:

Aşağı Öveçler Mah. 1329 Sok. No:6/9 Öveçler ANKARA / TURKEY
Tel: +90 (312) 472 81 60-67 Fax: +90 (312) 472 82 51

Factory:

1. Organize Sanayi Bölgesi Parsel 249/5 Beyköy - DÜZCE / TÜRKİYE
Tel: +90 (380) 553 73 88 Fax: +90 (380) 553 71 29