

NCE(D) HQ.F

Energy saving twin circulating pumps with flanges



APPLIES TO EUROPEAN DIRECTIVE FOR ENERGY RELATED PRODUCTS



Designation

NCE (D) HQ 40 F - 120 / 220

Series _____
 Twin pumps version _____
 Version _____
 DN ports in mm _____
 With flanges _____
 Max. head in dm _____
 connection size mm _____

Features

Smart pump

NCE(D) HQ.F adapt its functions to the system: the circulator measures the pressure and the flow and adjusts the speed to the selected pressure.

Easy use

There are different operating modes selectable from the control panel.

Construction

Energy saving variable speed circulating pump driven by a permanent magnet synchronous motor (pm) controlled by on board inverter.

- Dry running detection
- Automatic venting function

NCE single head digital input and output

- Start / stop input
- Relay output

On demand

- Max / Min input
- 0-10V input
- 4-20 mA input
- PWM input
- Modbus (RS485 and TCP / IP)
- Web server
- Bacnet

NCED Twin head digital input and output

- Start / stop input
- 2 nos. relay outputs
- Max / Min input
- 0-10V input
- 4-20 mA input
- PWM input
- Modbus (RS485 and TCP / IP)
- Web server
- Bacnet

Applications

Heating and conditioning systems.

Operating conditions

- Liquid temperature from -10 °C to +110 °C
- Ambient temperature from 0 °C to +40 °C
- Maximum permissible working pressure: 10 bar
- Storage: -20°C/+70°C max. relative humidity 95% at 40 °C
- Certifications: in conformity with CE requirements
- Sound pressure \leq 40 dB (A).
- Minimum suction pressure: - 0,05 bar at 75 °C
- 0,28 bar a 90 °C.
- Maximum glycol quantity: 20%.
- EMC according to: EN 55014-1, EN 55014-2
EN 61000-3-2, EN 61000-3-2.
- Connections: Flanges according to PN 6/10, EN 1092-2, DN 32,40,50,65,80,100.
- The benchmark for most efficient circulators is $EEL \leq 0,20$.

Motor

Synchronous motor with permanent magnet.

- Motor: variable speed
- Standard voltage: single-phase 230 V (-10%;+6%)
- Frequency: 50/60 Hz
- Protection: IP 44
- Insulation class: F
- Overload protection (integrated).
- Cable: phases and neutral.
- Constructed in accordance with: EN 60335-1, EN 60335-2-51.

Operating modes



Automatic mode

(factory setting):

In this mode the pump automatically sets the operating pressure, depending on the hydraulic system. This mode is recommended in most systems.



Proportional pressure mode:

The circulator changes the pressure proportionally to the current flow. The pressure value can be adjusted with the + and - buttons.



Constant pressure mode:

The circulator maintains the pressure constant when the reference flow changes. The pressure value can be adjusted with the + and - buttons.



Fixed speed mode:

The circulator works with constant curve and the curve could be changed using + e - buttons.



Night mode:

When the liquid temperature fall by 15-20°C the pump automatically swiches to night mode, in practice the circulator works at minimum curve. When the temperature rises again the pump comes back to the selected mode. The night mode could be selected with any operating mode.

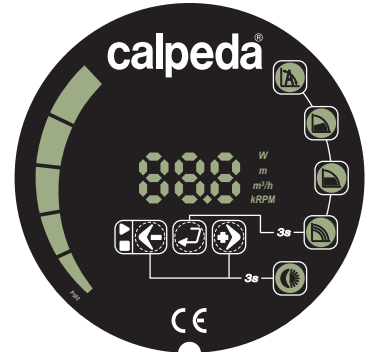

Operating mode-control panel

NCE HQ.F could works in:

- automatic mode
- proportional pressure mode
- constant pressure mode
- fixed speed mode
- night mode

The night mode could be selected with any operating mode.

Coverage chart

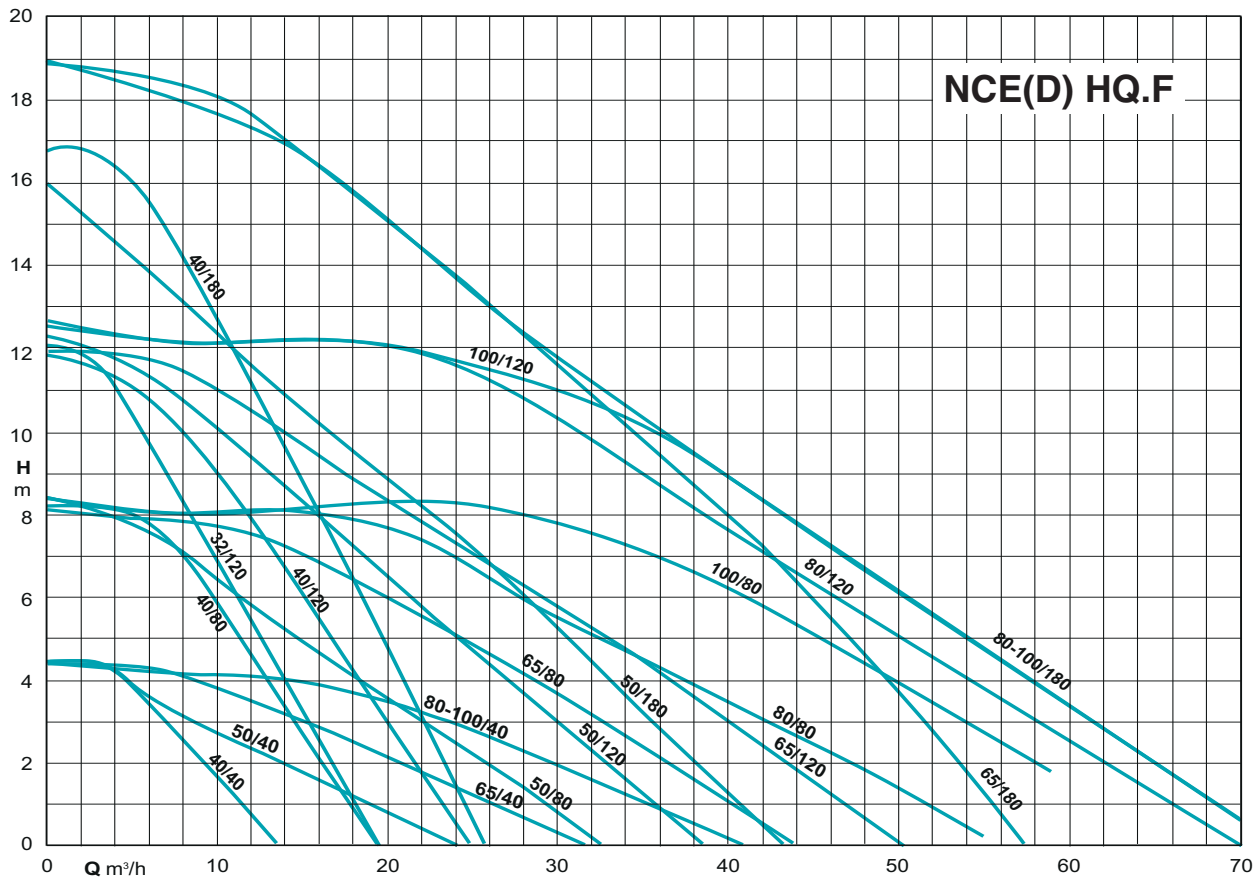

Characteristic curves

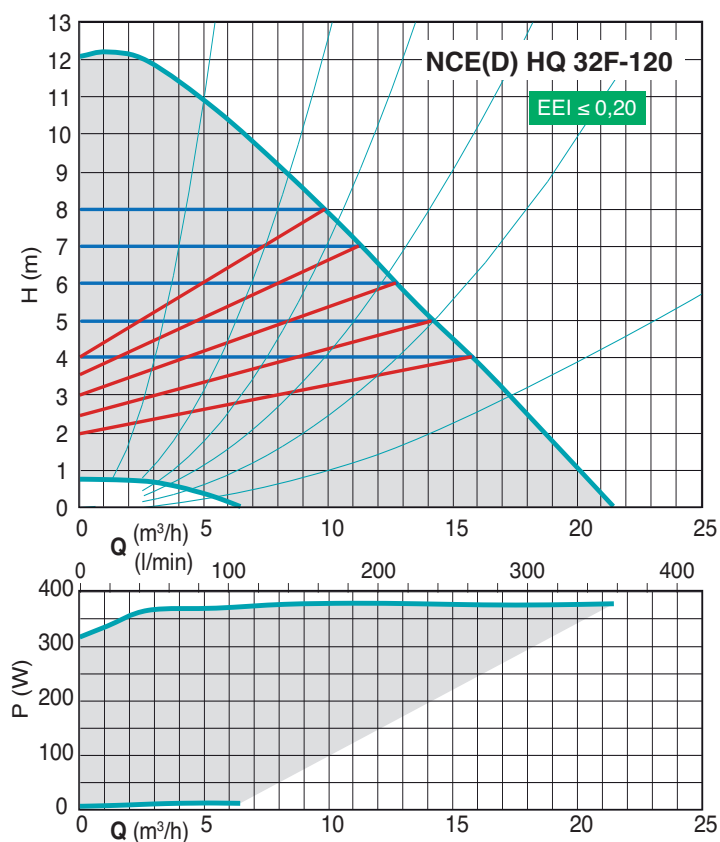

Characteristic curves

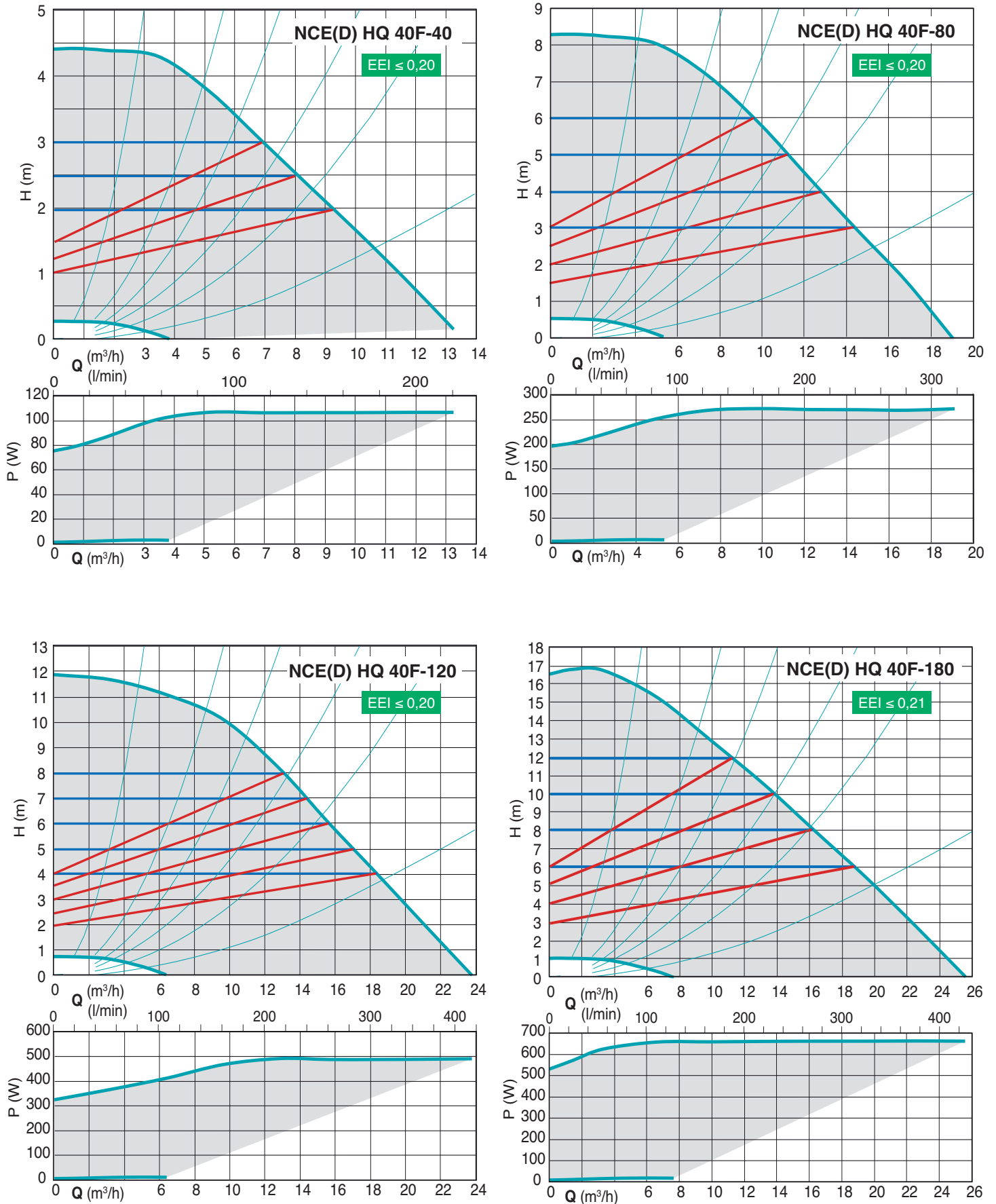

Characteristic curves

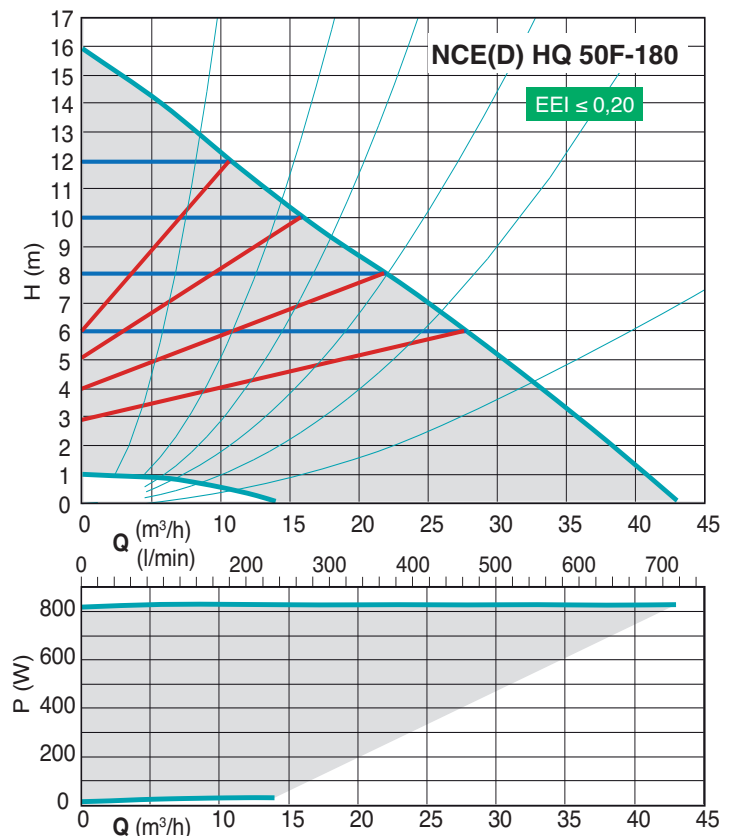
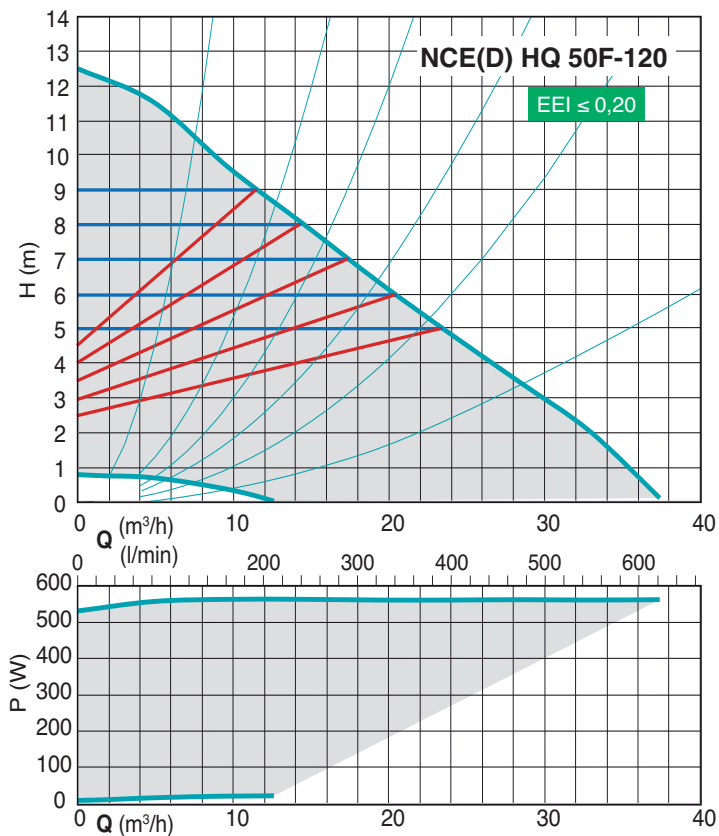
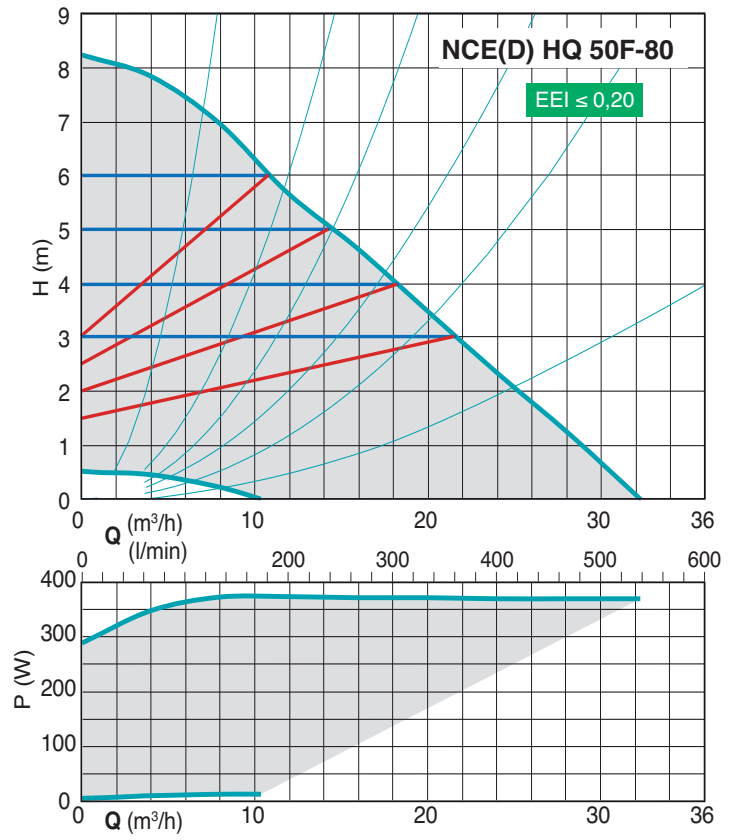
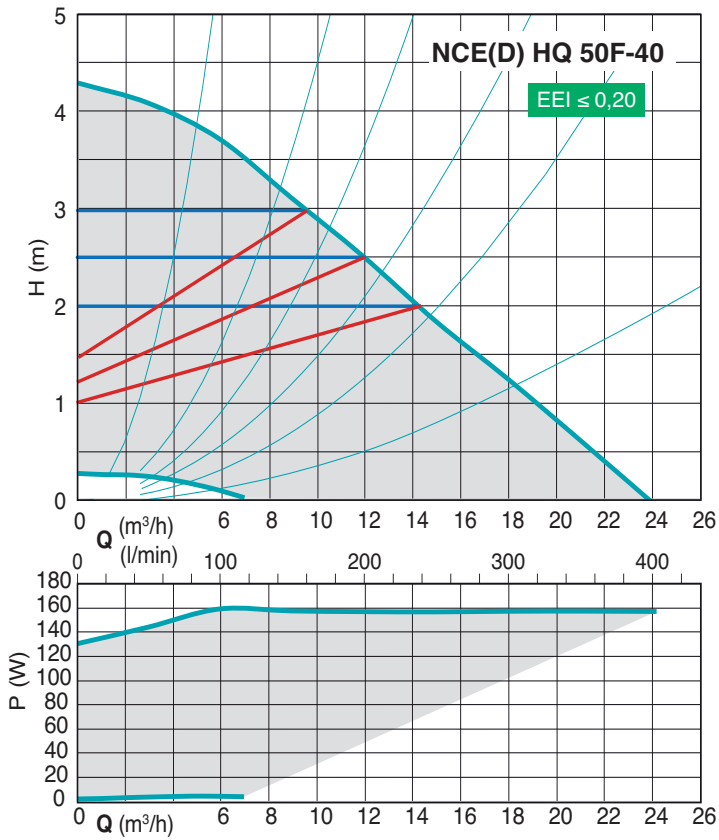

Characteristic curves

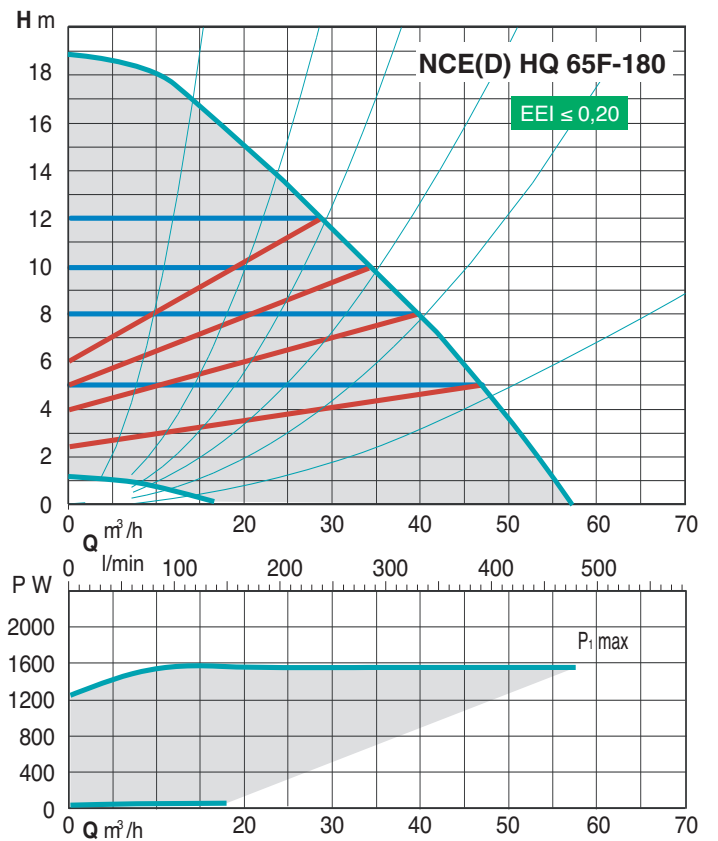
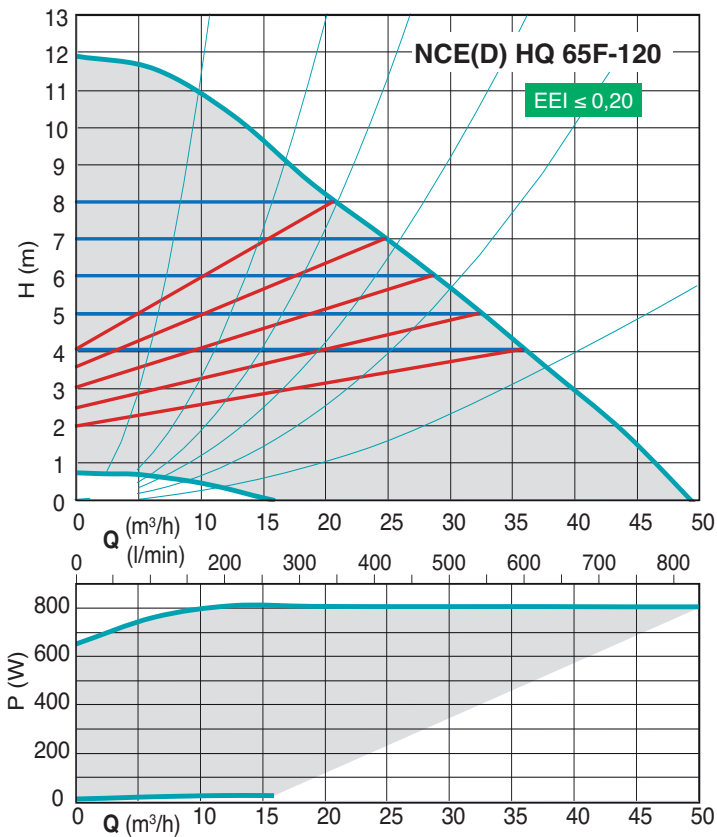
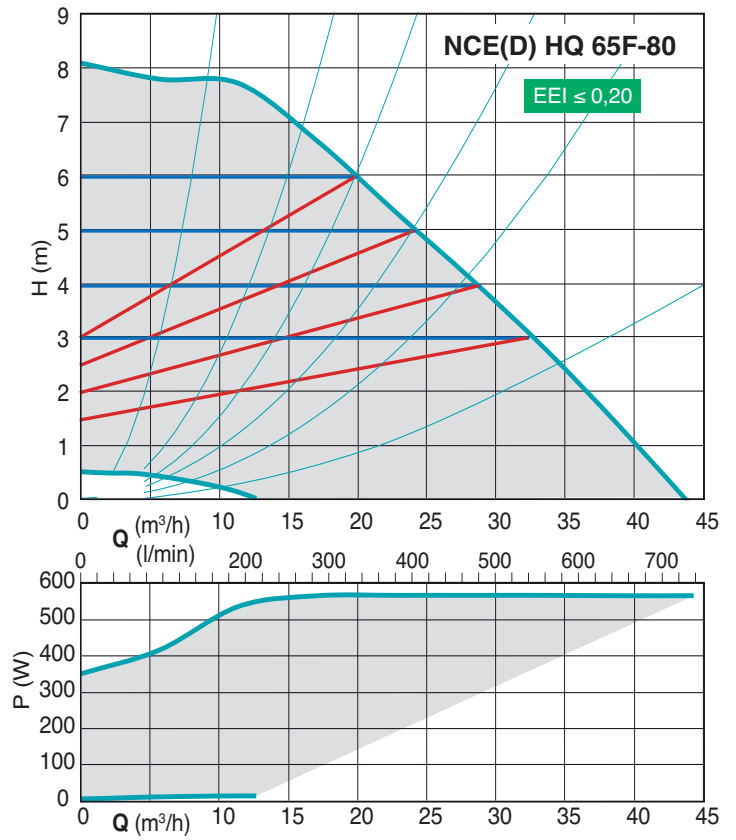
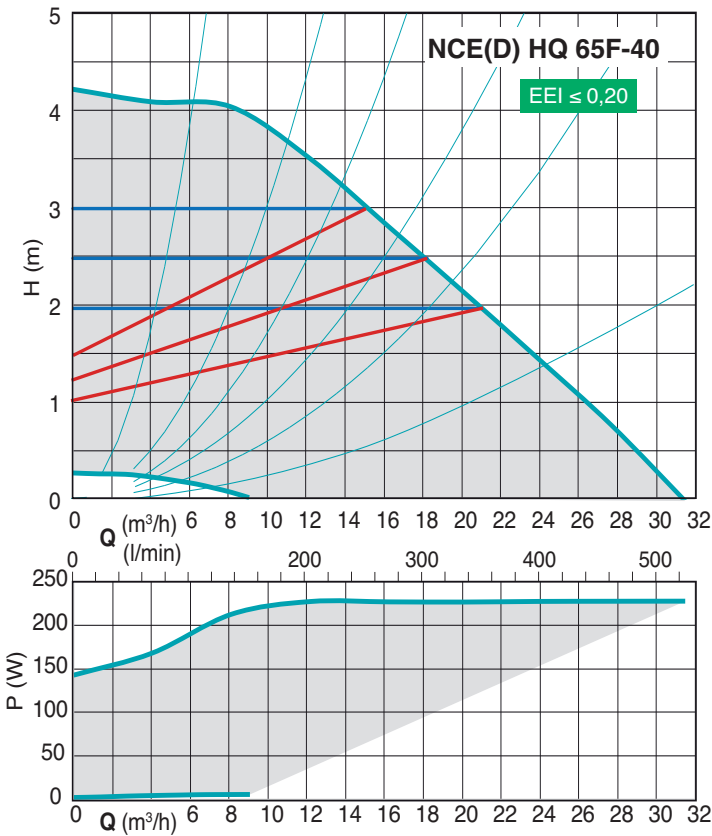

Characteristic curves

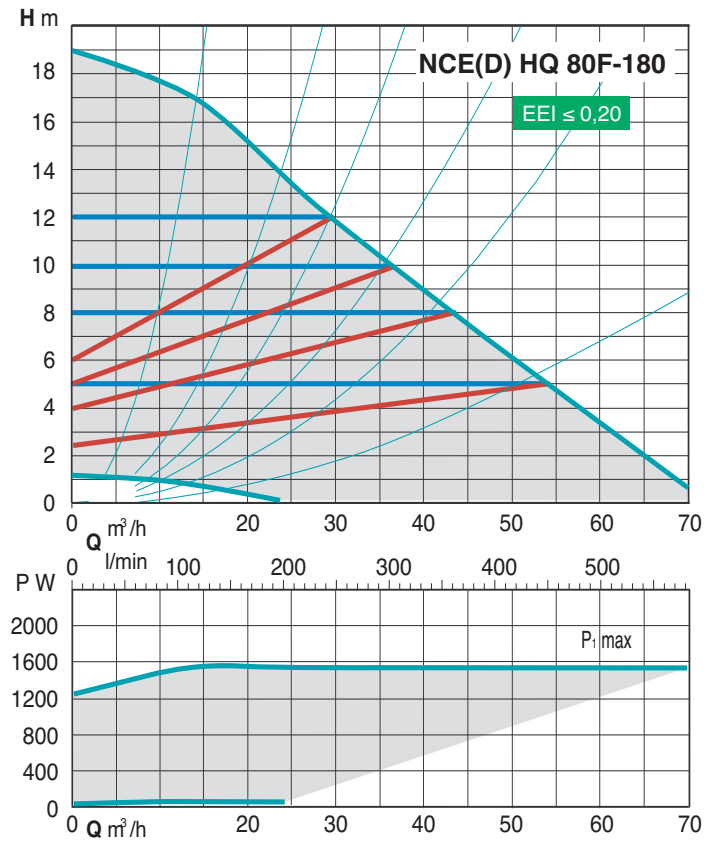
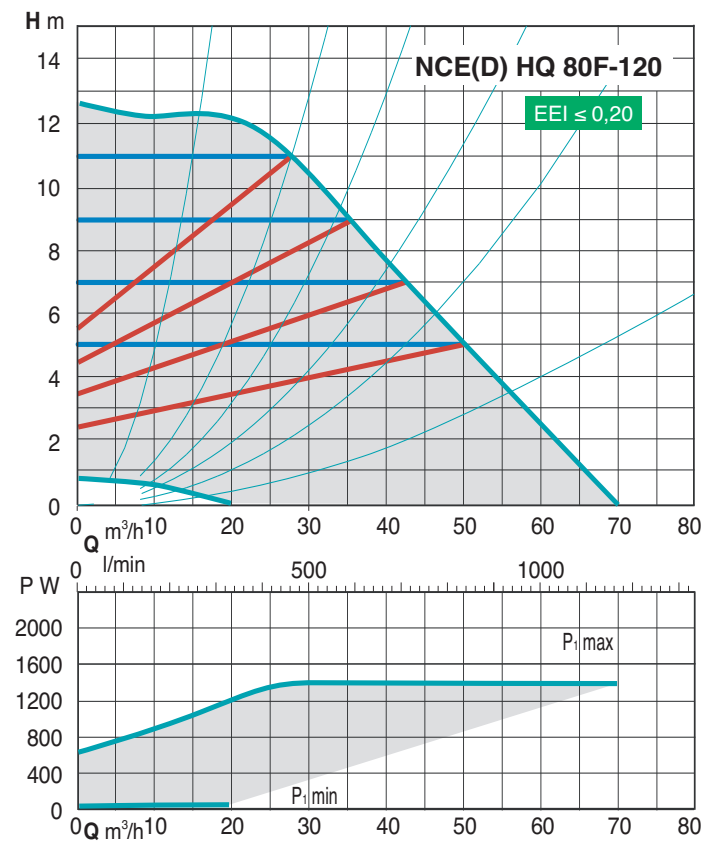
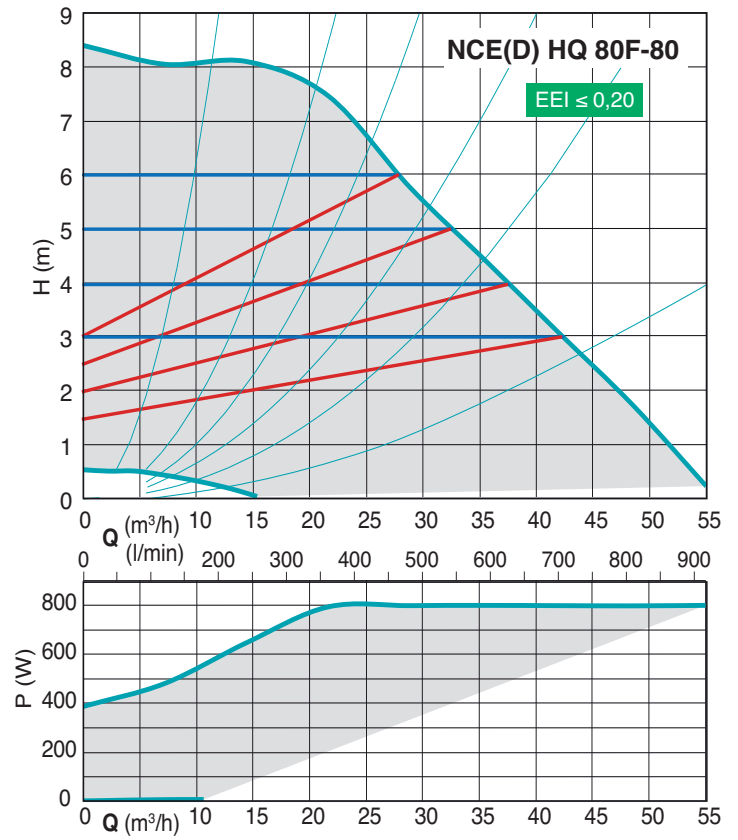
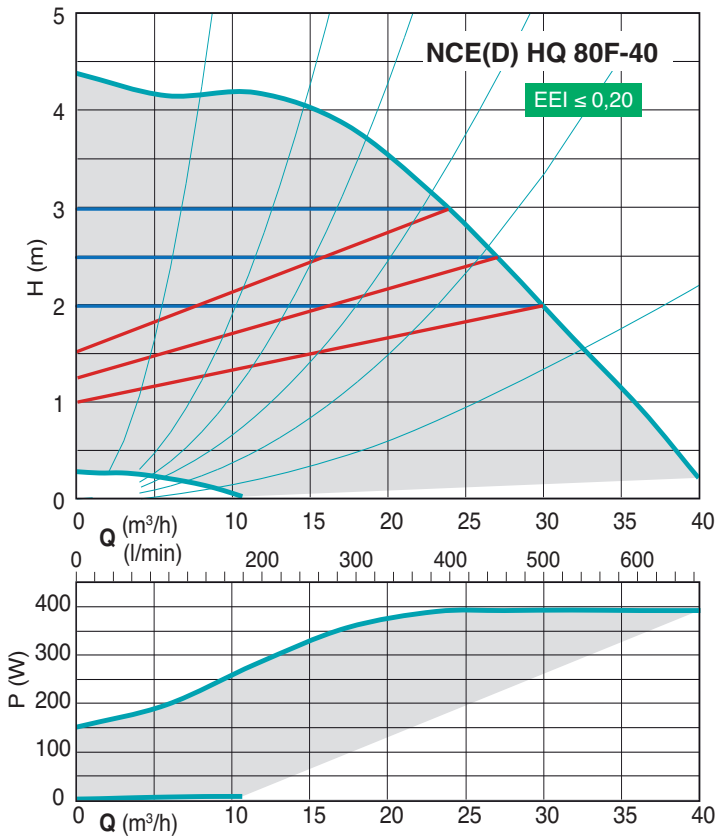

Characteristic curves

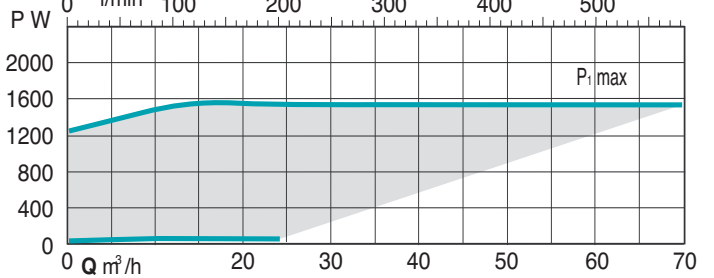
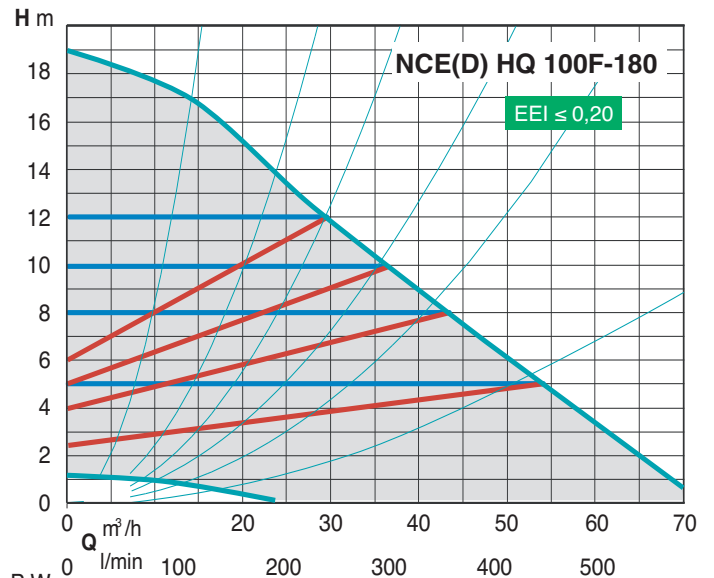
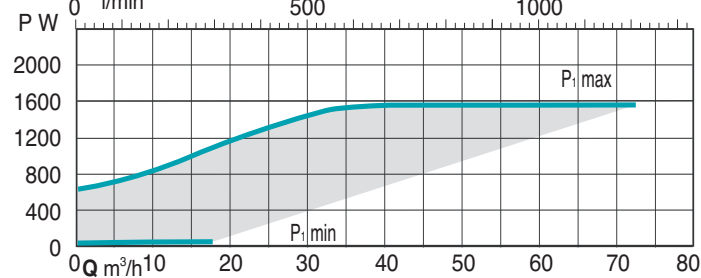
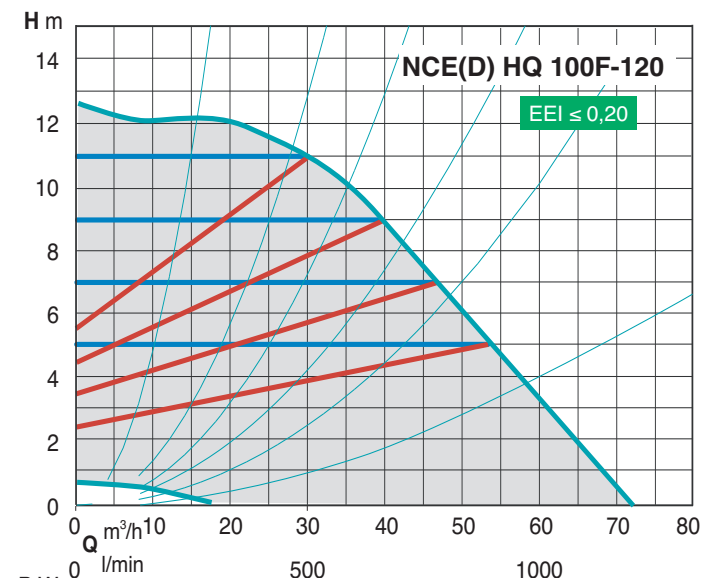
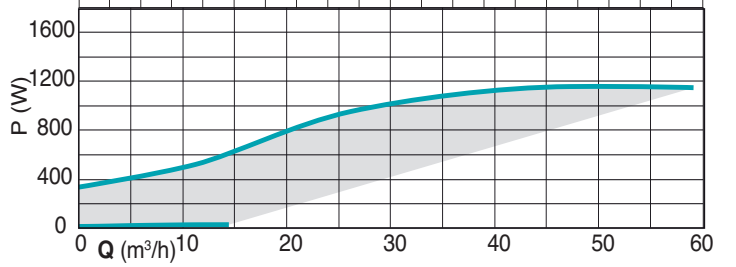
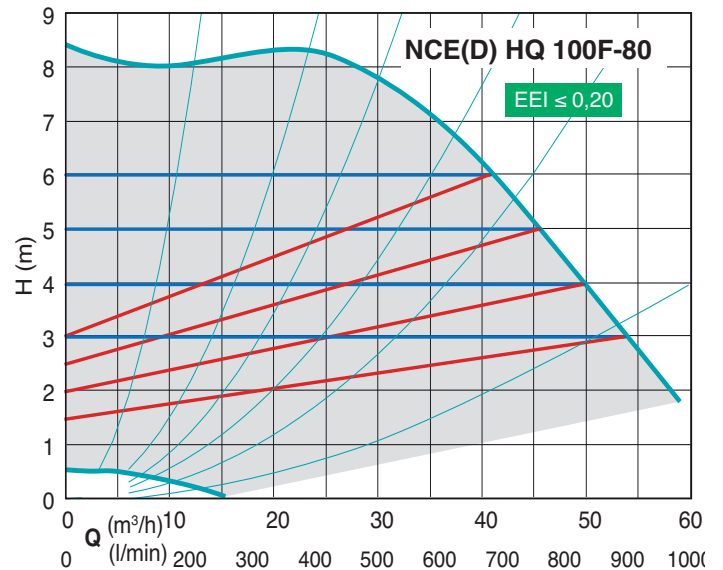
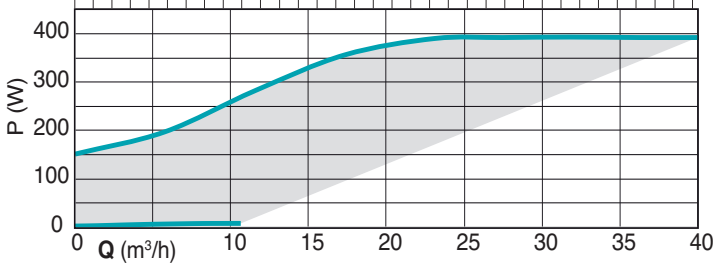
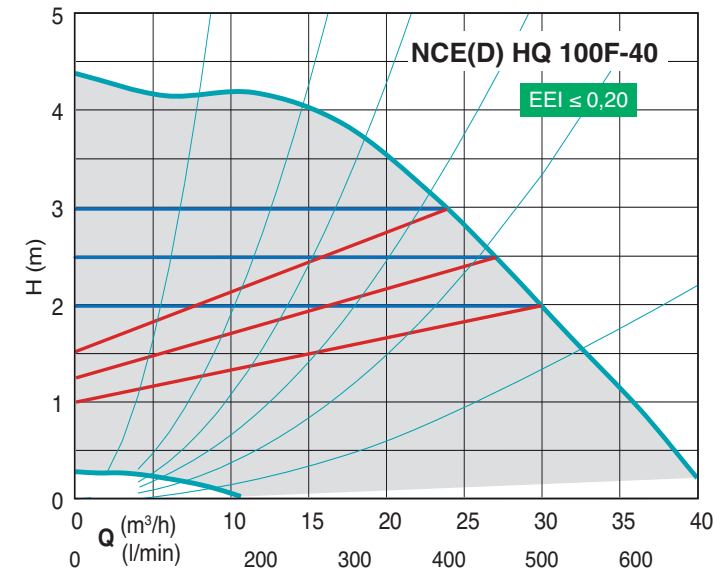

Materials

Component	Pos.	Material
Pump casing	1	Cast iron GJL 200 EN 1561
Impeller	2	Composite
Shaft	3	Stainless steel
Bearings	4	Carbon
Thrust bearing	5	Ceramic
Rotor	6	Stainless steel jacket
Winding	7	Copper wire
Electronic card	8	PA6 GF15 (Polyamide)
Gasket	9	EPDM

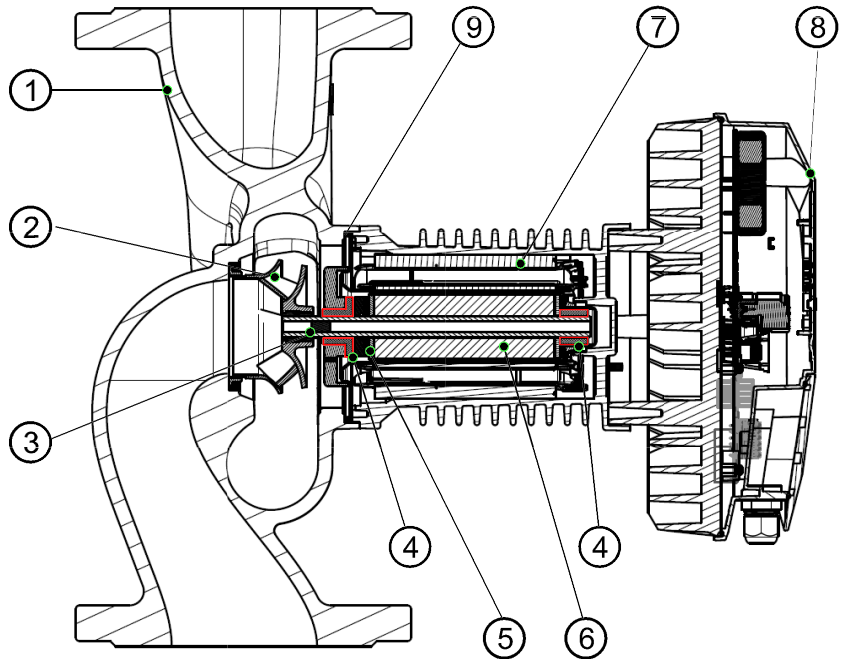

Examples of installations

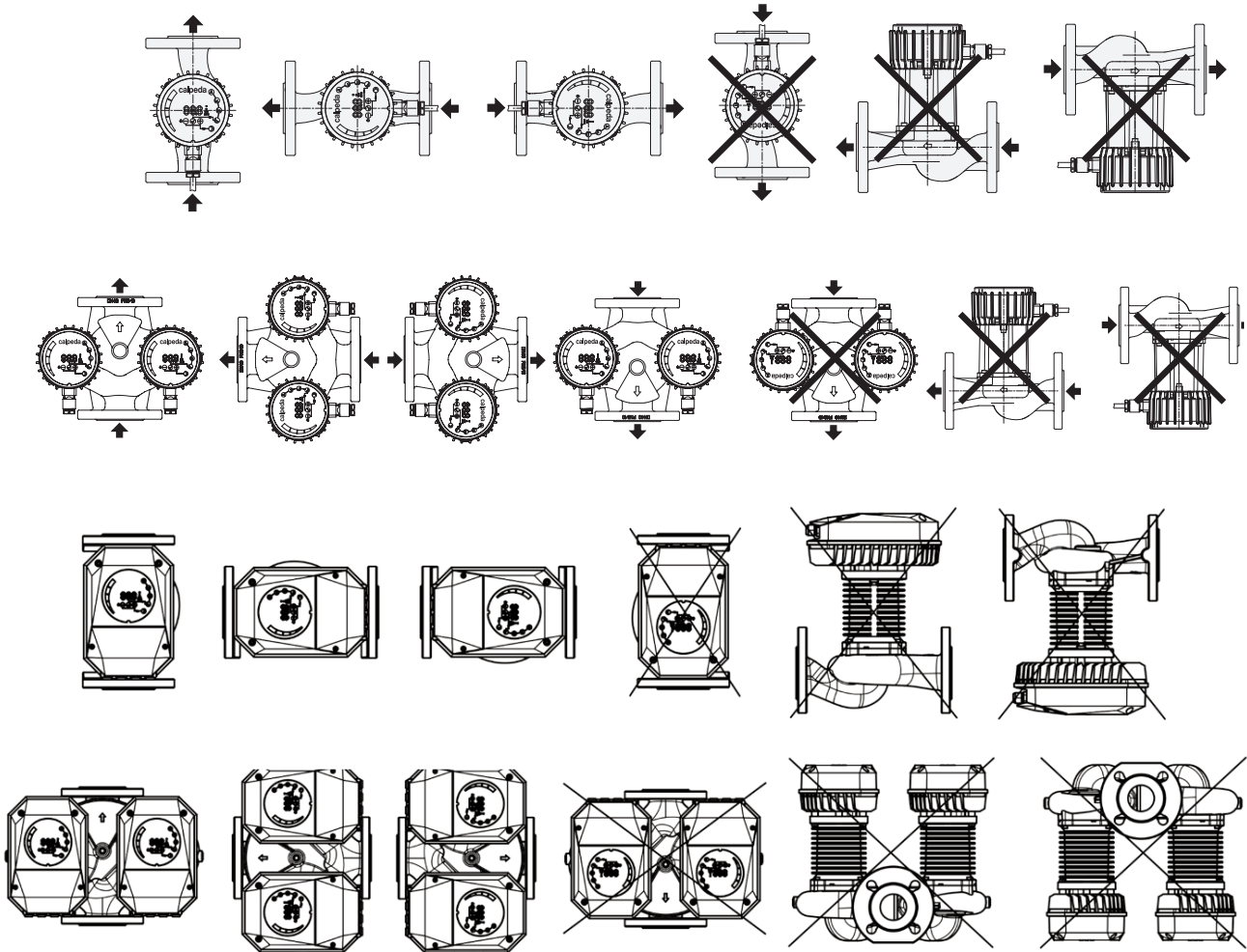

Dimensions and weights

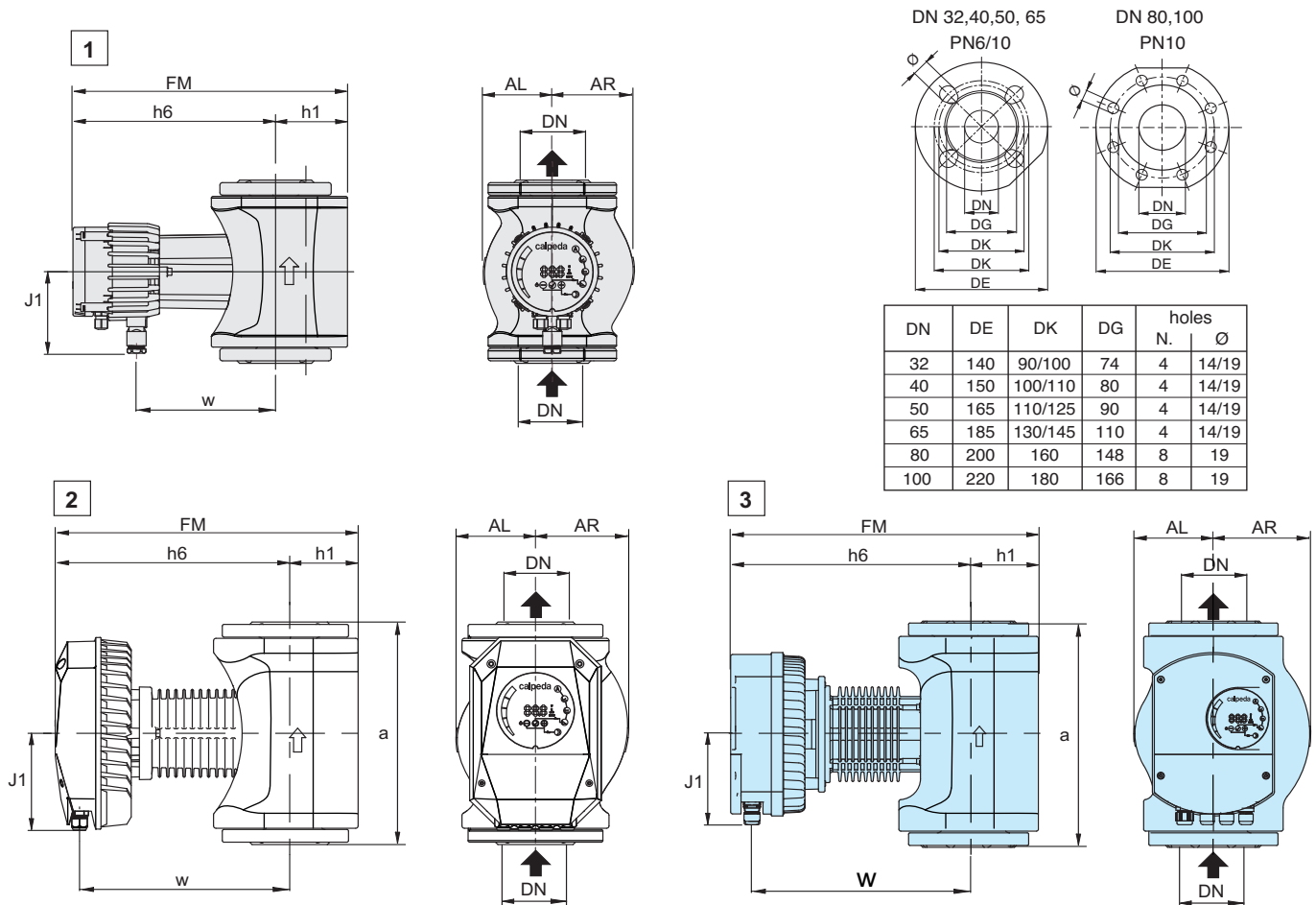

	TYPE	DN	H m	Q m ³ /h	1~ 230 V		P ₁		mm								kg
					A min	A max	W min	W max	a	J1	FM	h1	h6	w	AL	AR	
2	NCE HQ 32F-120/220/A	32	12	19	0,2	1.8	25	370	220	122	379	83	296	266	82	97	11,7
1	NCE HQ 40F-40/250/A	40	4	13	0,1	1	10	110	250	98	321	84	237	162	81	96	9,5
2	NCE HQ 40F-80/250/A	40	8	19	0,2	1.3	25	270	250	122	380	84	296	266	82	97	11,8
2	NCE HQ 40F-120/250/A	40	12	24	0,2	2.3	25	480	250	122	380	83	297	266	82	97	13,4
2	NCE HQ 40F-180/250/A	40	18	25	0,2	3.4	25	680	250	115	390	83	307	276	82	97	13,4
1	NCE HQ 50F-40/280/A	50	4	23	0,2	1.3	25	160	280	98	345	87	258	199	98	114	11
2	NCE HQ 50F-80/280/A	50	8	32	0,2	1.7	25	370	280	122	371	84	287	157	96	114	14,5
2	NCE HQ 50F-120/280/A	50	12	36	0,2	2.5	25	560	280	122	371	84	287	157	96	114	14,5
2	NCE HQ 50F-180/280/A	50	18	42	0,2	3.6	25	830	280	122	381	84	297	167	96	114	14,5
2	NCE HQ 65F-40/340/A	65	4	31	0,2	1.1	25	230	340	122	402	95	307	226	96	118	17,9
2	NCE HQ 65F-80/340/A	65	8	43	0,2	2.6	25	560	340	122	402	95	307	226	96	118	17,9
2	NCE HQ 65F-120/340/A	65	12	50	0,2	3.5	25	810	340	122	412	95	317	236	96	118	18,4
3	NCE HQ 65F-180/340	65	18	57	0,2	7,4	25	1550	340	137	454	96	358	325	95	120	23,8
2	NCE HQ 80F-40/360/A	80	4	40	0,2	1.8	25	390	360	122	415	108	307	278	123	150	24,8
2	NCE HQ 80F-80/360/A	80	8	53	0,2	3.5	25	800	360	122	425	108	317	288	123	150	24,8
3	NCE HQ 80F-120/360	80	12	69	0,2	6,2	25	1400	360	144	476	108	368	335	124	150	30
3	NCE HQ 80F-180/360	80	18	72	0,2	7,4	25	1550	360	144	476	108	368	335	124	150	30
2	NCE HQ 100F-40/450/A	100	4	40	0,2	2.4	25	550	450	144	415	108	307	278	123	150	28,9
3	NCE HQ 100F-80/450	100	8	59	0,2	5	25	1150	450	144	476	108	368	335	124	150	35,1
3	NCE HQ 100F-120/450	100	12	72	0,2	7,4	25	1550	450	144	476	108	368	335	124	150	35,1
3	NCE HQ 100F-180/450	100	18	72	0,2	7,4	25	1550	450	144	476	108	368	335	124	150	35,1

Dimensions and weights

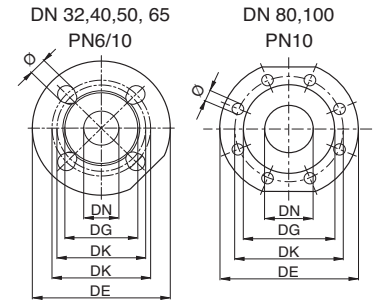
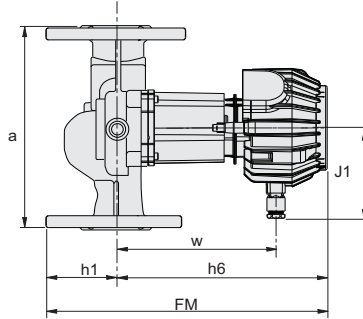
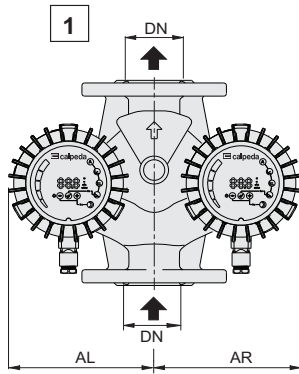

DN	DE	DK	DG	holes	
				N.	Ø
32	140	90/100	74	4	14/19
40	150	100/110	80	4	14/19
50	165	110/125	90	4	14/19
65	185	130/145	110	4	14/19
80	200	160	148	8	19
100	220	180	166	8	19

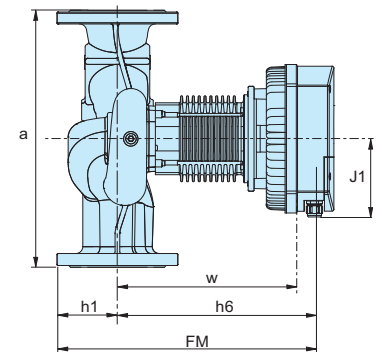
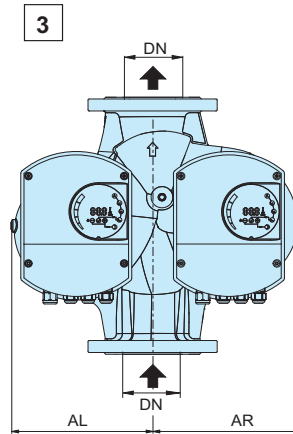
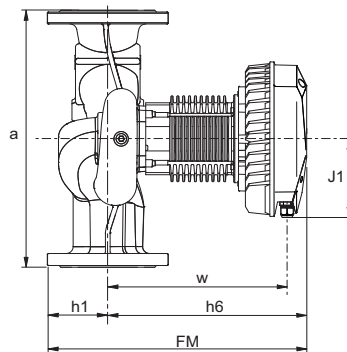
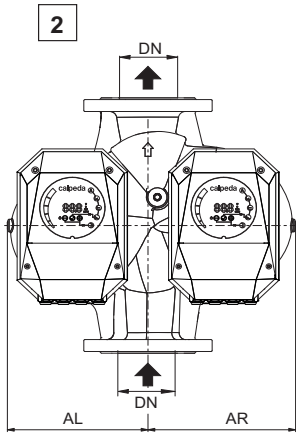

	TYPE	DN	H m	Q m ³ /h	1~ 230 V		P ₁		mm								kg
					A min	A max	W min	W max	a	J1	FM	h1	h6	w	AL	AR	
2	NCED HQ 32F-120/220/A	32	12	19	0,2	1.8	25	370	220	122	361	65	296	266	191	191	21,5
1	NCED HQ 40F-40/250/A	40	4	13	0,1	1	10	110	250	98	302	65	237	162	181	186	17,2
2	NCED HQ 40F-80/250/A	40	8	19	0,2	1.3	25	270	250	122	361	65	296	266	191	191	22,2
2	NCED HQ 40F-120/250/A	40	12	24	0,2	2.3	25	480	250	122	361	65	296	266	191	191	23,5
2	NCED HQ 40F-180/250/A	40	18	25	0,2	3.4	25	680	250	115	371	65	306	276	191	191	23,6
1	NCED HQ 50F-40/280/A	50	4	23	0,2	1.3	25	160	280	98	345	72	273	199	198	201	26
2	NCED HQ 50F-80/280/A	50	8	32	0,2	1.7	25	370	280	122	359	72	287	157	195	202	27,5
2	NCED HQ 50F-120/280/A	50	12	36	0,2	2.5	25	560	280	122	359	72	287	157	195	202	27,5
2	NCED HQ 50F-180/280/A	50	18	42	0,2	3.6	25	830	280	122	369	72	297	167	195	202	27,5
2	NCED HQ 65F-40/340/A	65	4	31	0,2	1.1	25	230	340	122	370	75	295	226	215	225	35,9
2	NCED HQ 65F-80/340/A	65	8	43	0,2	2.6	25	560	340	122	370	75	295	226	215	225	35,9
2	NCED HQ 65F-120/340/A	65	12	50	0,2	3.5	25	810	340	122	380	55	305	236	215	225	35,45
3	NCED HQ 65F-180/340	65	18	57	0,2	7,4	25	1550	340	137	454	96	358	325	216	226	47,5
2	NCED HQ 80F-40/360/A	80	4	40	0,2	1.8	25	390	360	122	400	93	307	278	240	252	45,6
2	NCED HQ 80F-80/360/A	80	8	53	0,2	3.5	25	800	360	122	410	93	317	288	240	252	45,9
3	NCED HQ 80F-120/360	80	12	69	0,2	6,2	25	1400	360	144	476	108	368	335	241	253	56,5
3	NCED HQ 80F-180/360	80	18	72	0,2	7,4	25	1550	360	144	476	108	368	335	241	253	56,5
2	NCED HQ 100F-40/450/A	100	4	40	0,2	2.4	25	550	450	144	410	104	306	278	240	252	50,6
3	NCED HQ 100F-80/450	100	8	59	0,2	5	25	1150	450	144	476	108	368	335	241	253	59
3	NCED HQ 100F-120/450	100	12	72	0,2	7,4	25	1550	450	144	476	108	368	335	241	253	59
3	NCED HQ 100F-180/450	100	18	72	0,2	7,4	25	1550	450	144	476	108	368	335	241	253	59