

# NM4, NMS4

**Close Coupled Centrifugal Pumps**  
n ≈ 1450 rpm

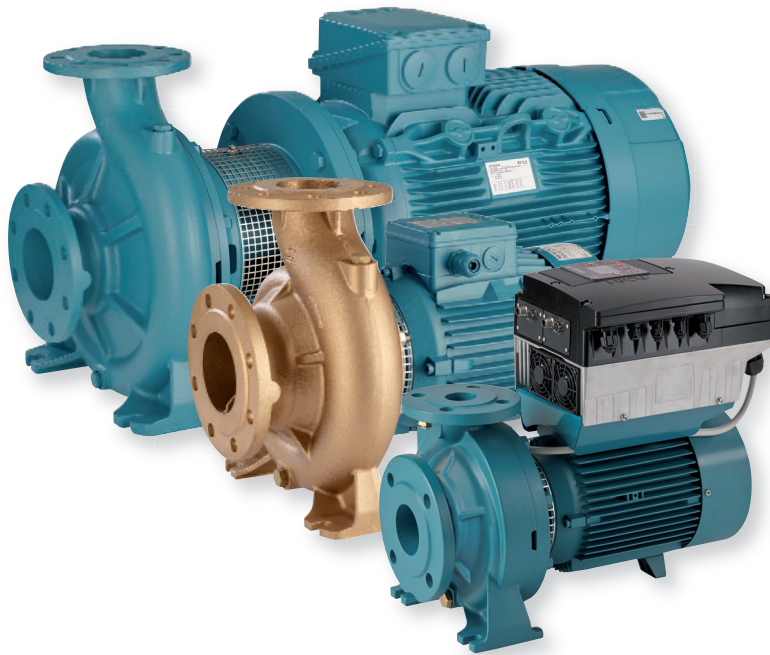

## Construction

Close-coupled centrifugal pumps; electric motor with extended shaft directly connected to the pump up to 15 kW, new bracket construction for standard motors (Stub-shaft construction) from 18,5 to 75 kW with integrated thrust bearing. Pump casing with axial suction and radial delivery on top, main dimensions and performance according to EN 733 with additional sizes for completion. NM(S)4: version with pump casing and lantern bracket in cast iron. B-NM(S)4: version with pump casing and lantern bracket/casing cover in bronze. (the pumps are supplied fully painted).

## Connections

Sizes	Connections
NM4 25/...	Threaded ports ISO 228
from NM4 32/.. to NMS4 150/..	Flanges PN 10, EN 1092-2 (PN 10 for DN 200)

## Counter-flanges (on request)

Sizes	Flanges
from NM4 32/.. to NM4 50/..	Screwed flanges EN 1092-1, PN 16
from NM4 32/.. to NMS4 150/..	Flanges for welding EN 1092-1, PN 10-16 (PN 10 for DN 200)

## Version with frequency converter (on request)

## Applications

For clean liquids without abrasives, which are non-aggressive for the pump materials (contents of solids up to 0,2%). For water supply. For heating, air conditioning, cooling and circulation plants. For civil and industrial applications. When low noise operating is required. For irrigation.

## Operating conditions

Liquid temperature from -10 °C to +90 °C.  
Ambient temperature up to 40 °C.  
Total suction lift up to 7 m.  
Maximum permissible working pressure up to 10 bar (16 bar for NM4 40/16,20; NM4 50/16; NM4 65/16,20,25; NM(S)4 80/16,20,25,31,400; NM4 100/20).  
Continuous duty.

## Motor

4-pole induction motor, 50 Hz (n ≈ 1450 rpm).  
**NM4, NMS4:** three-phase 230/400 V ± 10% up to 3 kW; 400/690 V ± 10% from 4 to 75 kW.  
Insulation class F. Protection IP 54 (IP 55 for NMS4).  
Motor suitable for operation with frequency converter from 0,75 kW.  
**IE3 efficiency class for three-phase motors (IE2 up to 0,65 kW).**  
Constructed in accordance with: EN 60034-1; EN 60034-30-1.

## Special features on request

- Other voltages. - Frequency 60 Hz (as per 60 Hz data sheet).
- Protection IP 55. - Special mechanical seal.
- Higher or lower liquid or ambient temperatures.
- Motor suitable for operation with frequency converter up to 0,55 kW.

The electropumps NM4, B-NM4, NMS4, B-NMS4 series comply with the European Regulation no. 547/2012.

## Materiali

Components	NM4, NMS4	B-NM4, B-NMS4
Pump casing	Cast iron	Bronze
Lantern bracket NM4	GJL 200 EN 1561	CC480K EN 1982
Casing cover for NMS4		
Lantern bracket NMS4	Cast iron GJL 200 EN 1561	
Impeller	Cast iron GJL 200 EN 1561	Bronze CC480K EN 1982
	Brass CW617N EN 12165 For NM4 25/125 - 25/160 - 25/200 - NM4 32/16 - 32/20 - 40/20	
Shaft	Cr-Ni steel AISI 303	Cr Ni Mo steel
	AISI 430 from 1,5 kW to 15 kW	AISI 316
Mechanical seal	Carbon - Ceramic - NBR	
Counter-flanges	Steel 1.0044 EN 10025-2 (Fe 430B)	

## Coverage chart n ≈ 1450 rpm

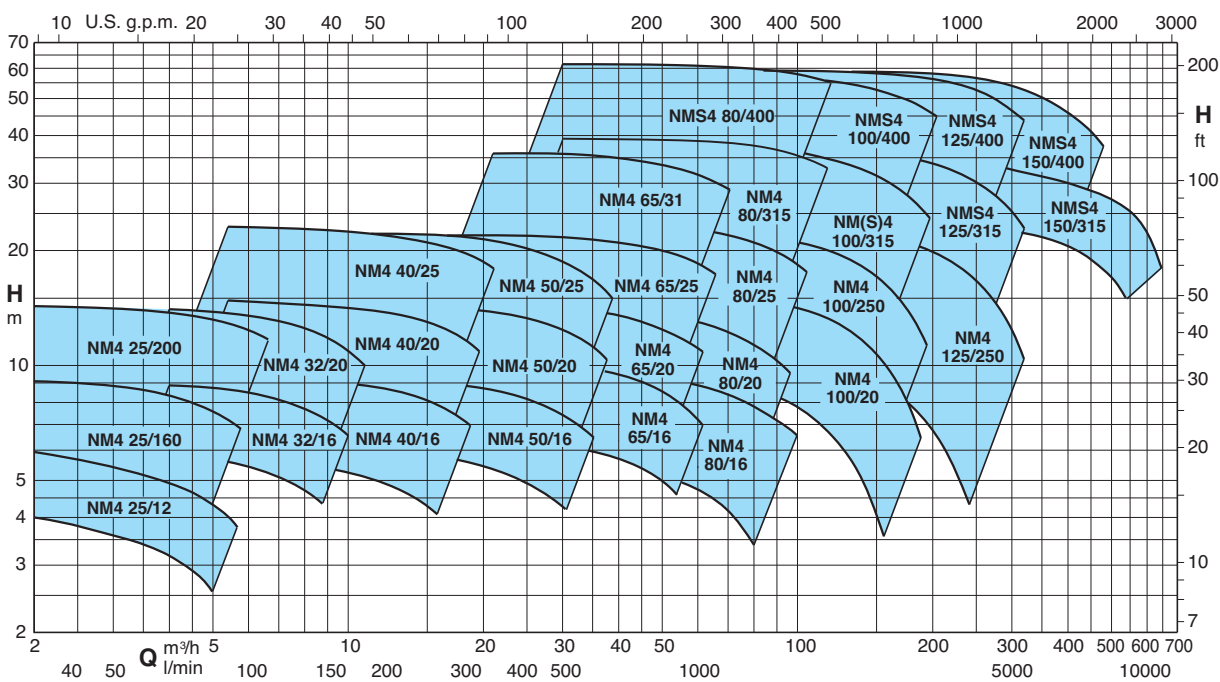

### Pumps with frequency converter

The **NM4 EI** pumps are available with power from 0,25 kW up to 30 kW, the pumps are equipped with **I-MAT** installed on board which allows to realize a variable-speed system extremely compact and efficient, ideal in applications of water supply and in the distribution of hot and cold water.

The pump is equipped with transducers suitable for operation and is already programmed at the factory.

#### Advantages

- Energy saving
- Compact design
- Easy to use
- Programmable to suit the system requirements
- Reliability

#### Costruction

The system comprises of:

- Pump
- Induction motor
- I-MAT Frequency converter
- Motor adapter for the motor mounting of the frequency converter
- Connection cable between frequency converter and induction motor
- Transducers

#### Main features

- Rated motor power output from 0,25 kW to 30 kW
- Control range from 870 to 1450 rpm (4-pole)
- Protection against dry running
- Protection against operations with closed valve ports
- Protection against system leakages
- Protection against overcurrent in the motor
- Protection against overvoltage and undervoltage of the power supply
- Protection against current unbalances between phases



### Operating modes



#### Constant pressure mode with pressure transducer

In this mode, the system maintains the preset pressure when the flow required by the installation changes.

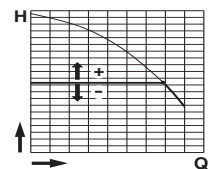

#### Proportional pressure mode with pressure transducer

In this mode the system changes the working pressure according to the required flow rate.

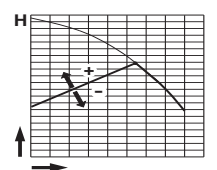

#### Constant flow mode with flow meter

In this mode the system maintains a constant flow rate value in a point of the installation according to the required pressure.

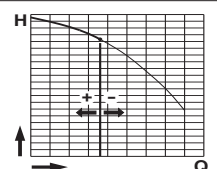

#### Fixed speed mode with setting of the speed preferential rotation.

In this mode, by changing the working frequency, you may choose any operational curve included within the working range.

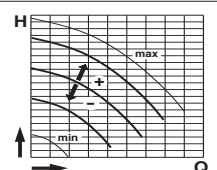

#### Constant temperature mode with temperature transducer

In this mode the system keeps the temperature constant inside a system by changing the speed of the pump.





### Characteristic curves $n \approx 1450$ rpm

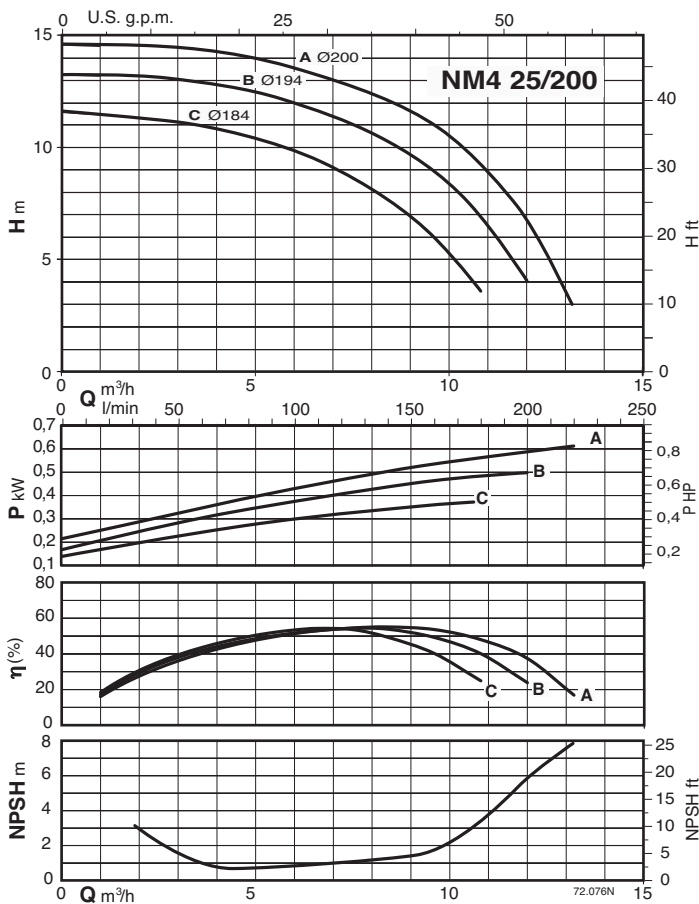
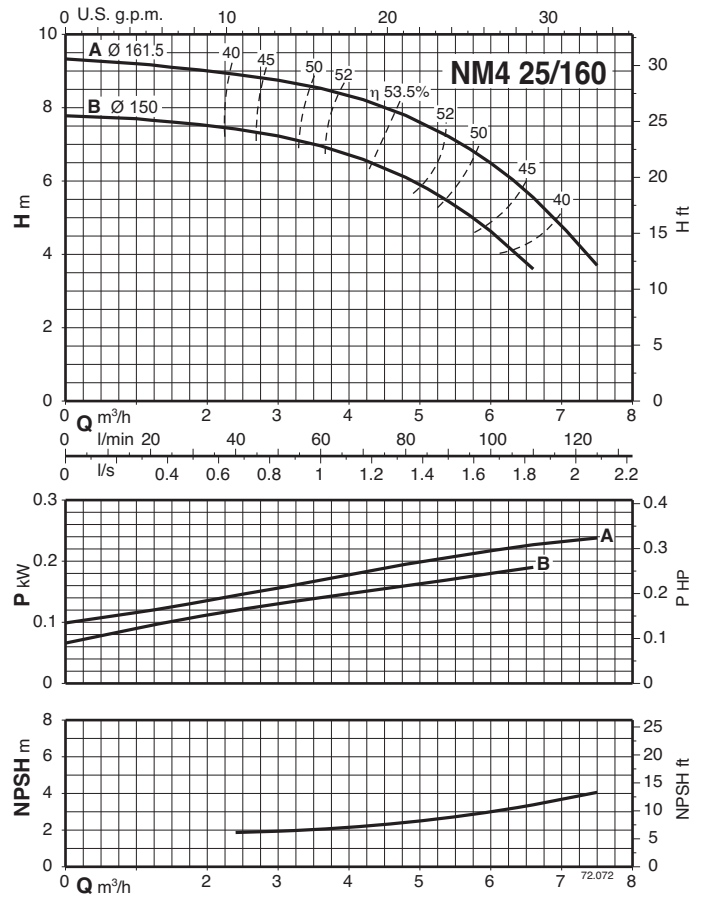
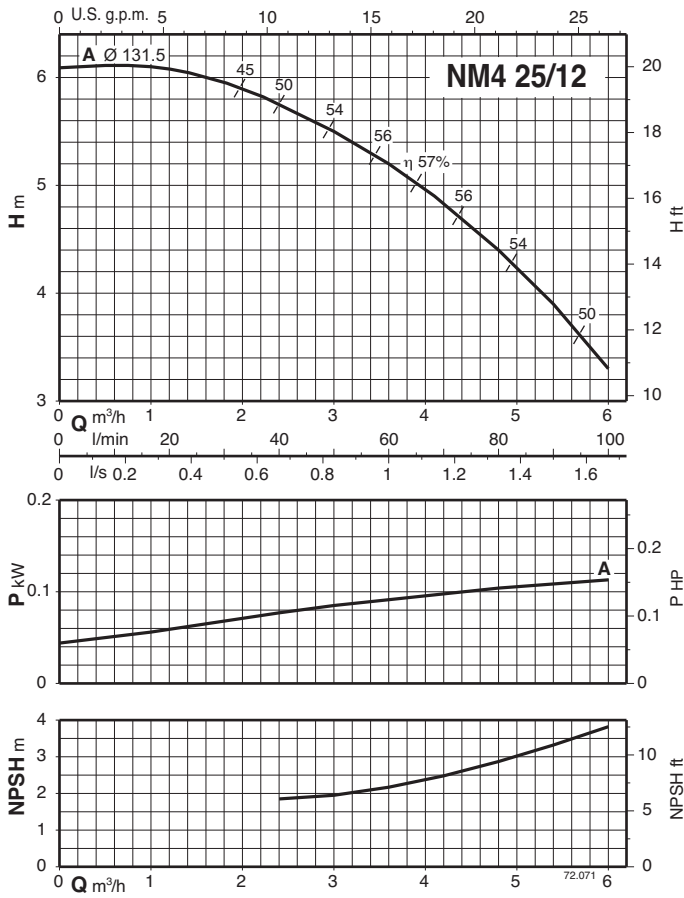



### Characteristic curves $n \approx 1450$ rpm

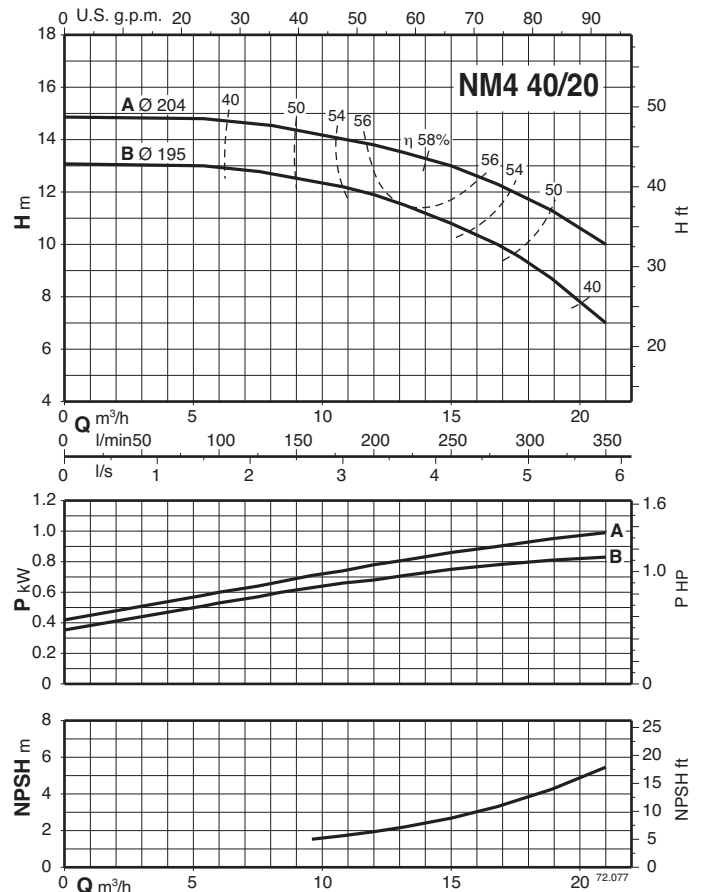
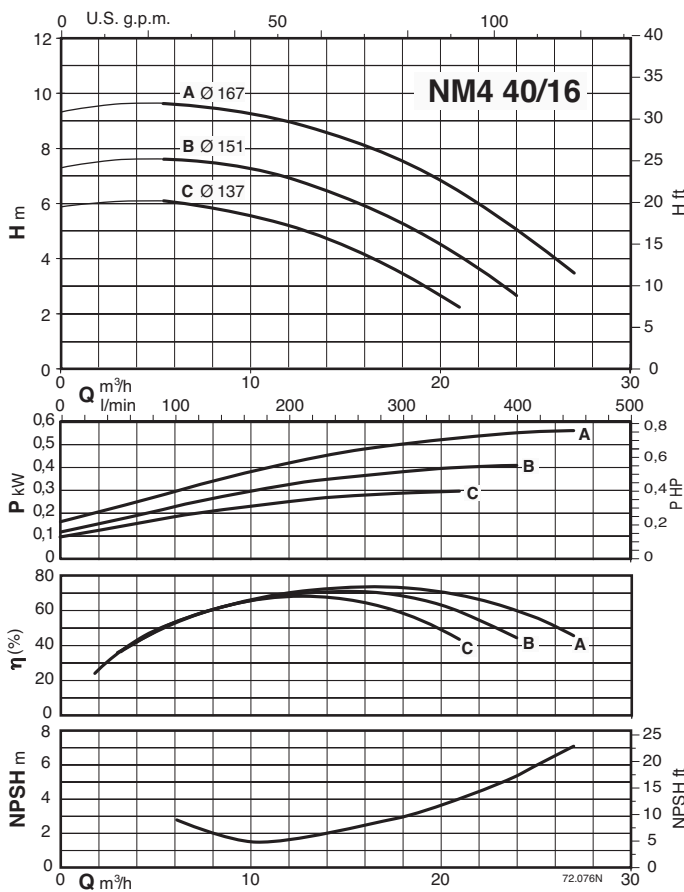
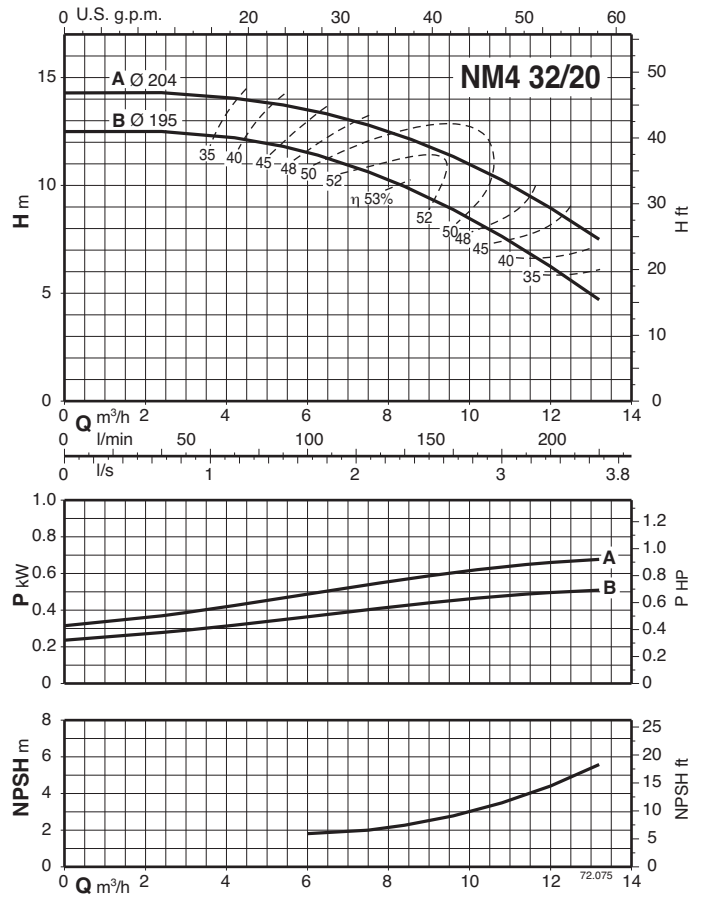
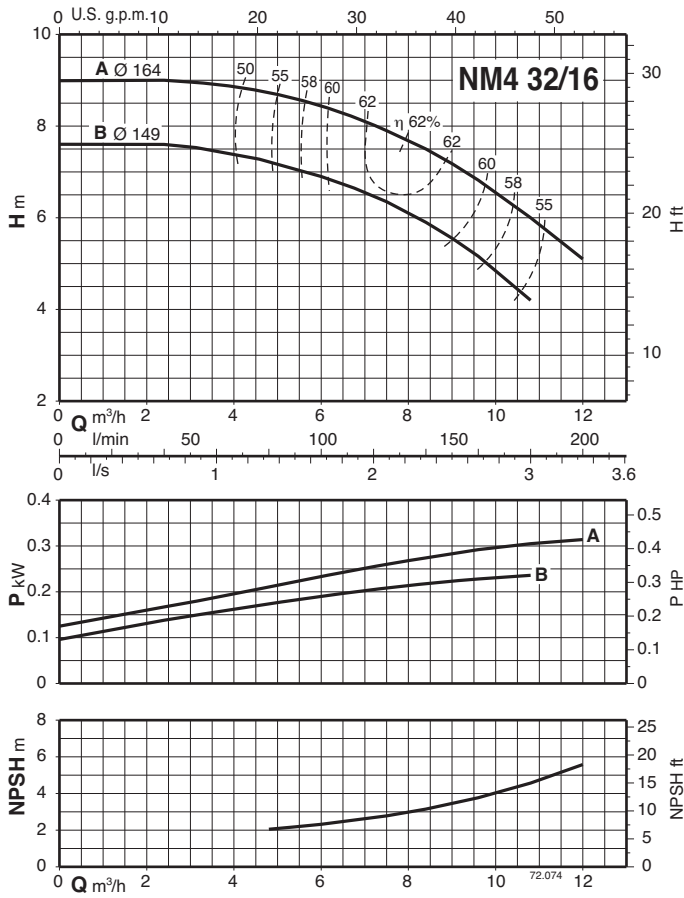

### Characteristic curves $n \approx 1450$ rpm

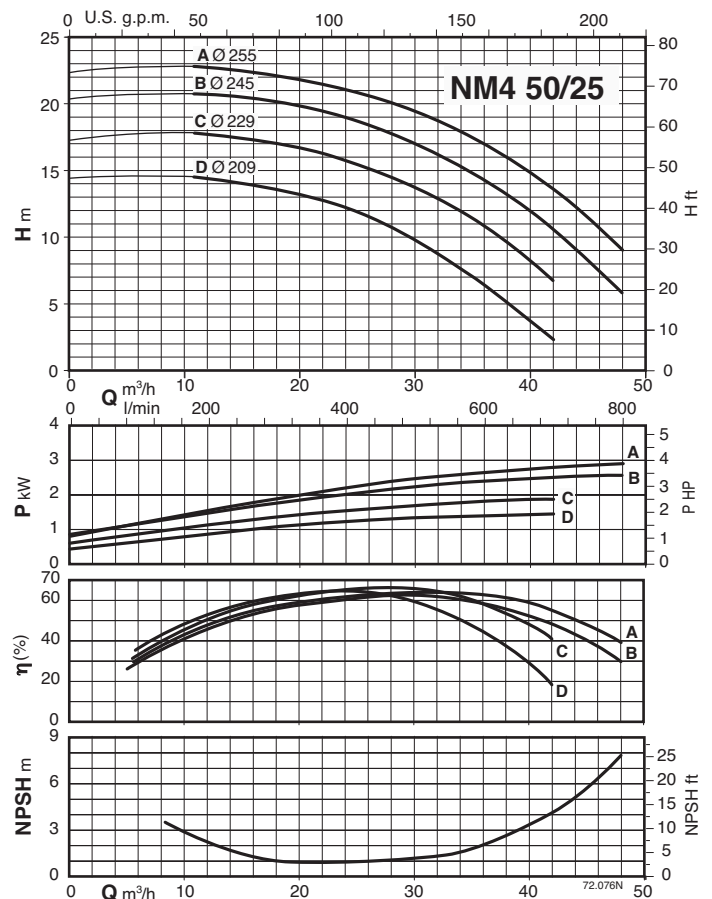
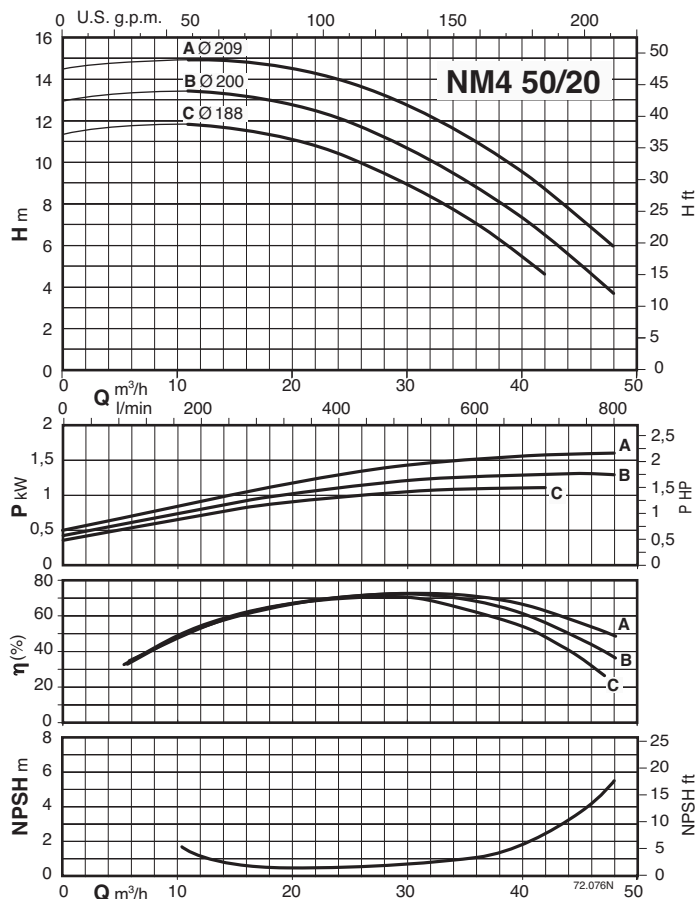
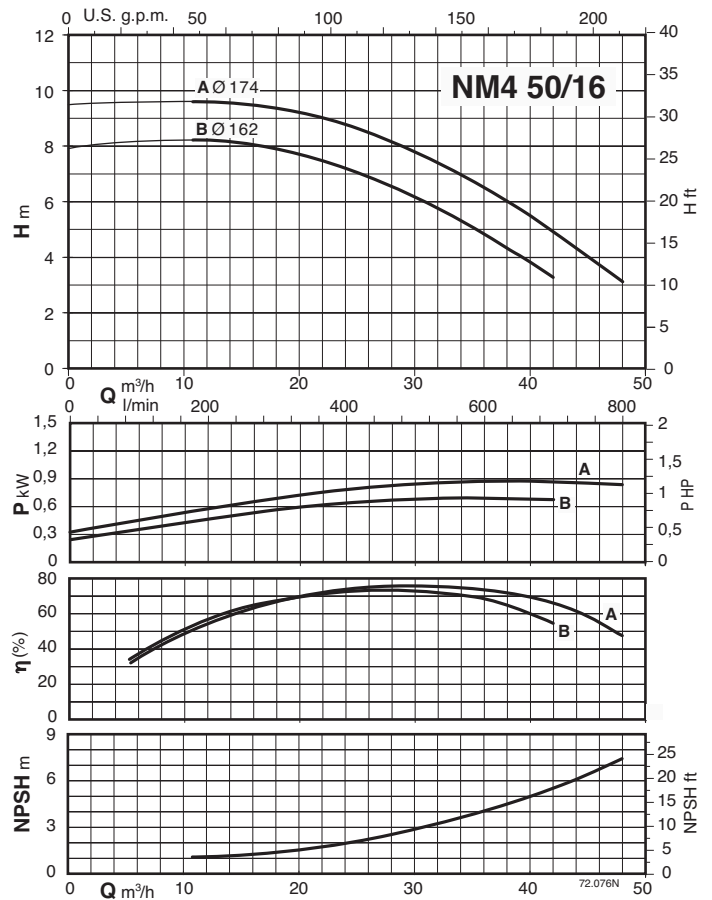
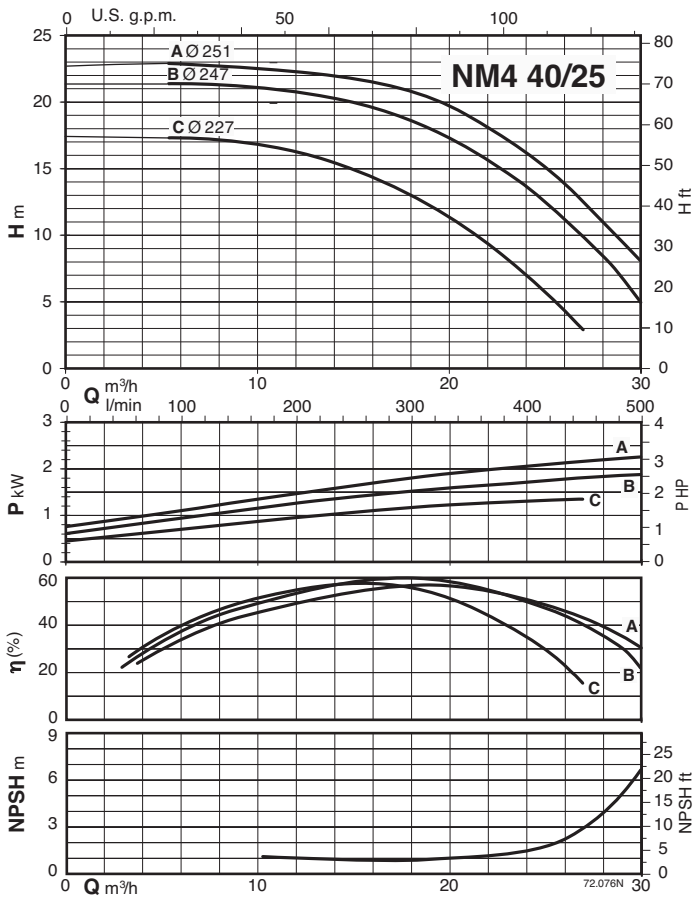

### Characteristic curves $n \approx 1450$ rpm

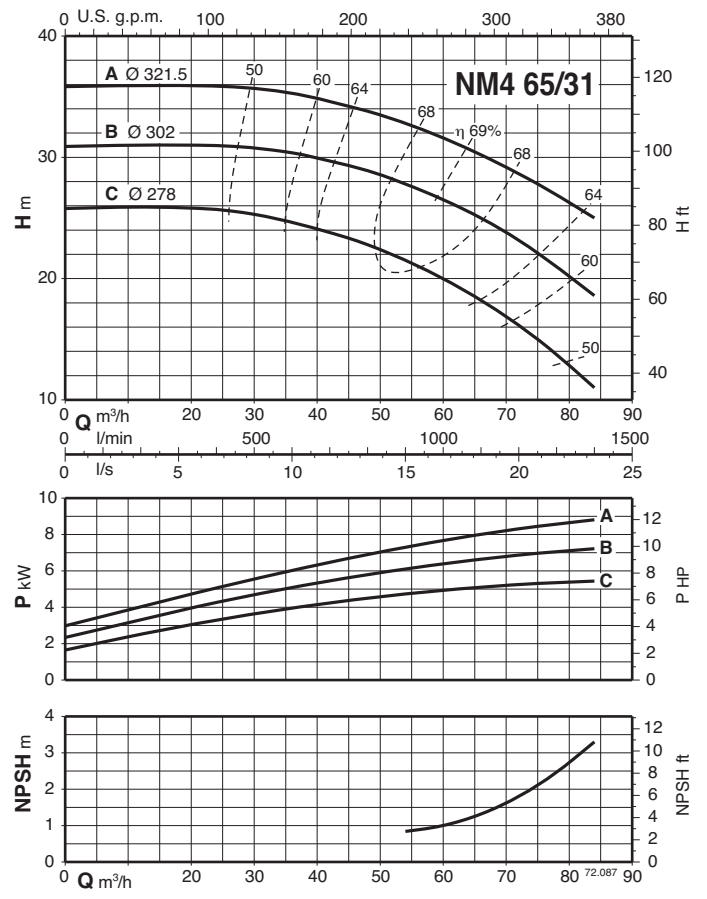
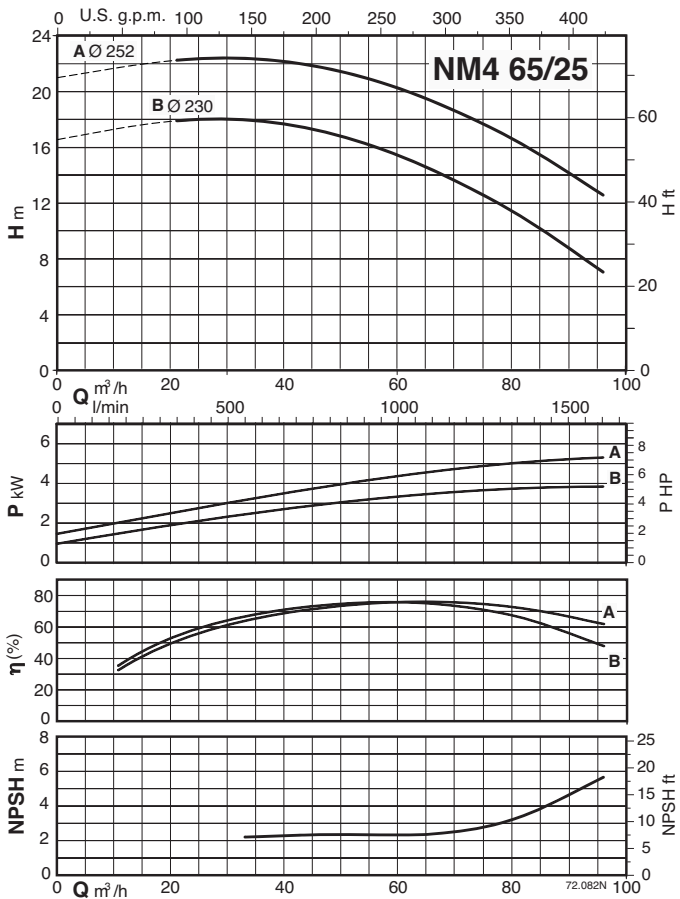
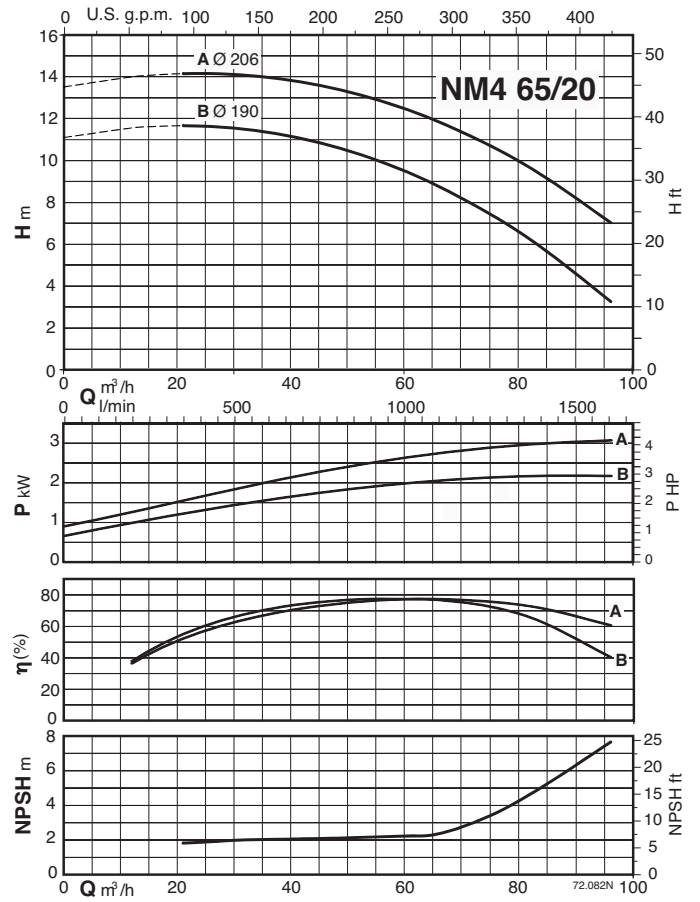
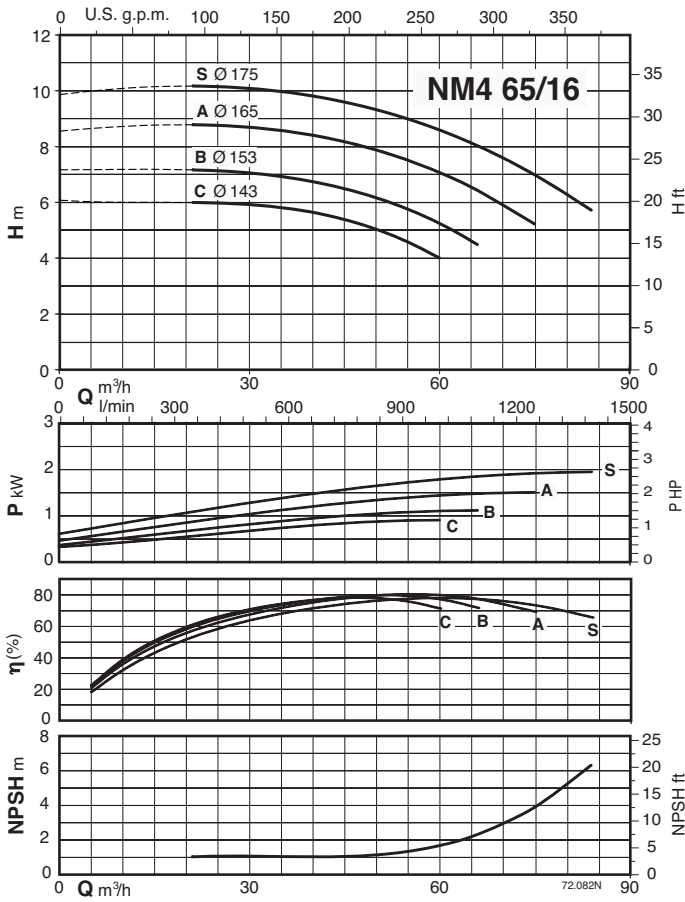



### Characteristic curves $n \approx 1450$ rpm

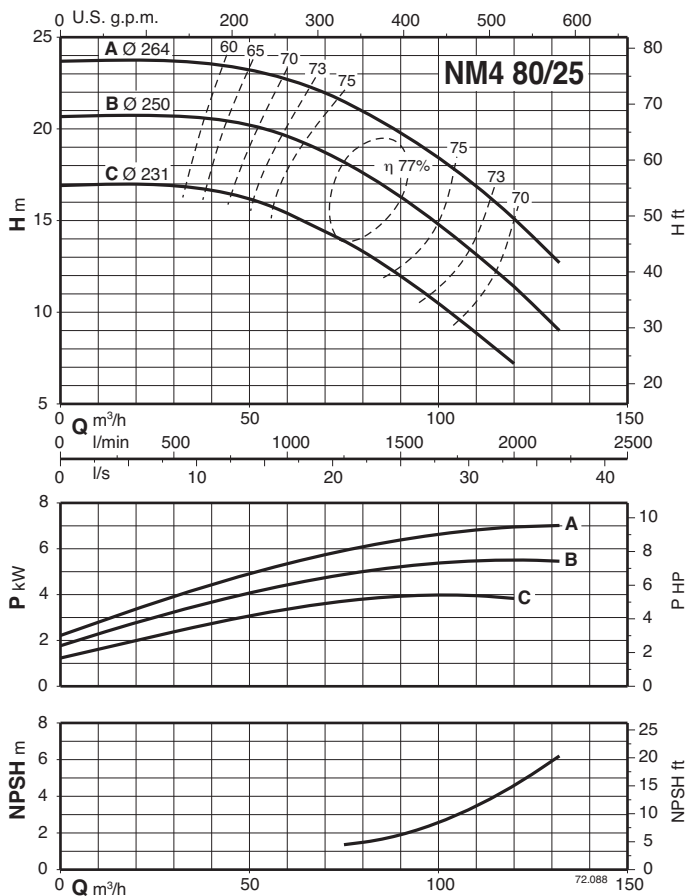
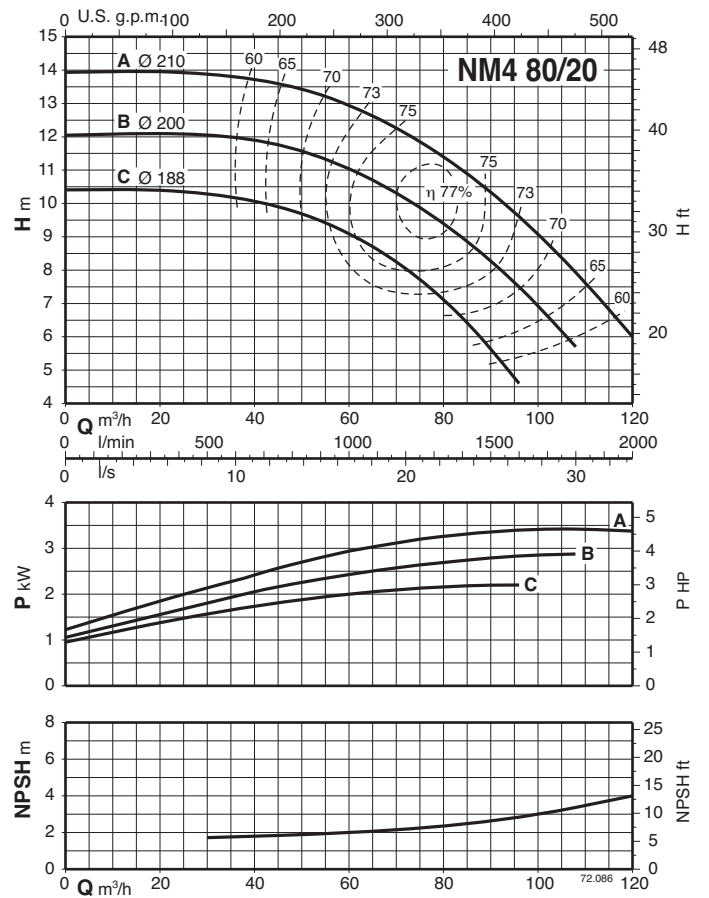
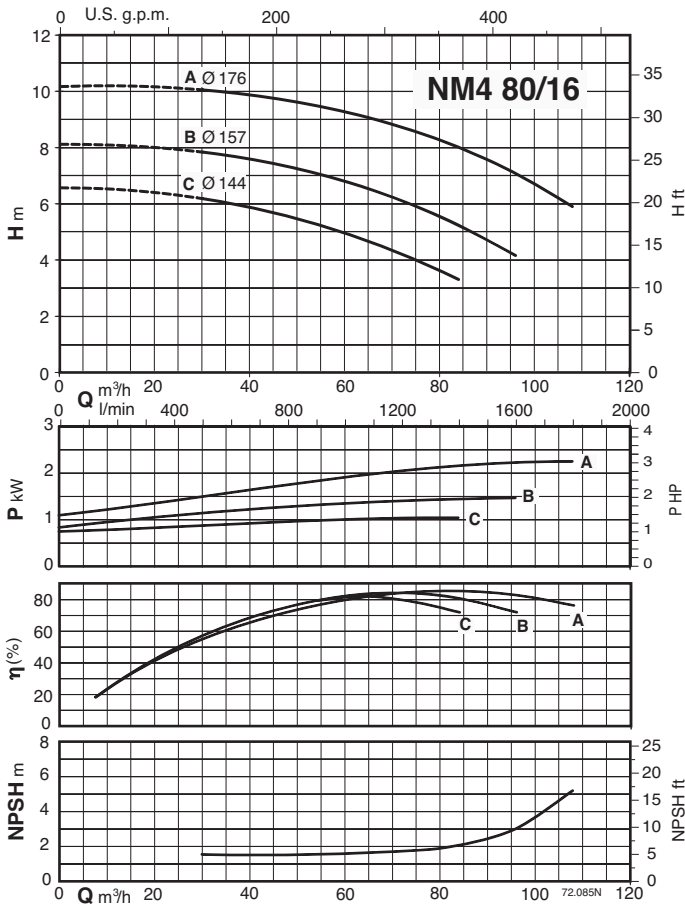

### Characteristic curves $n \approx 1450$ rpm

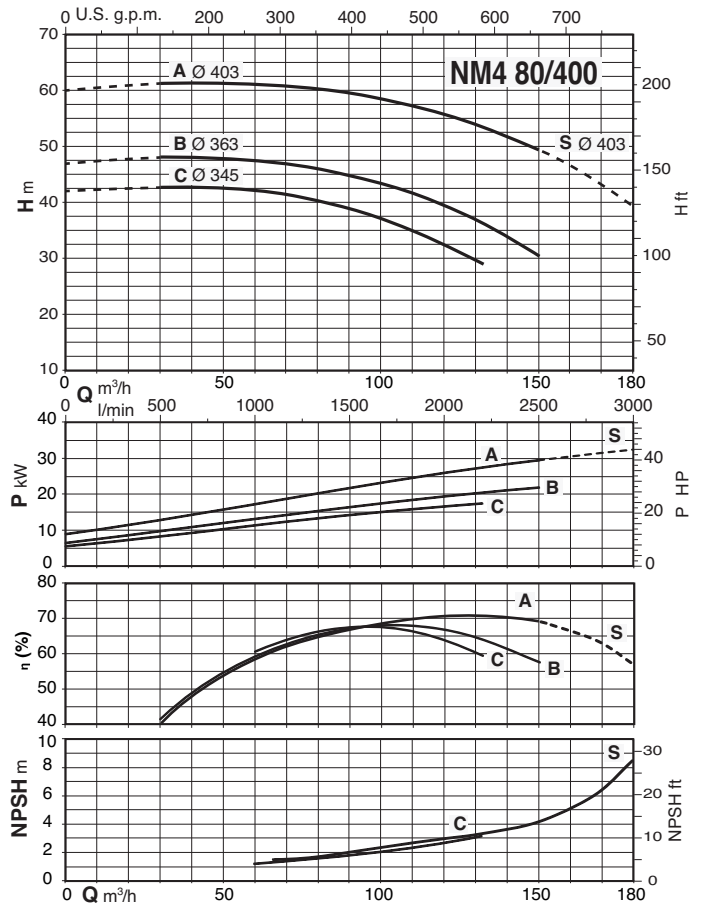
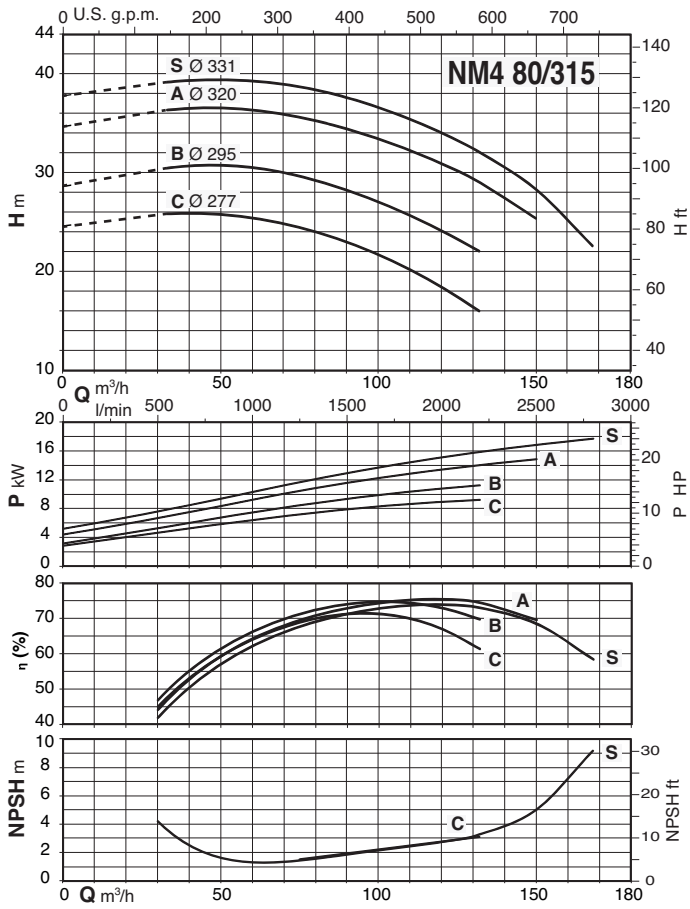

### Characteristic curves $n \approx 1450$ rpm

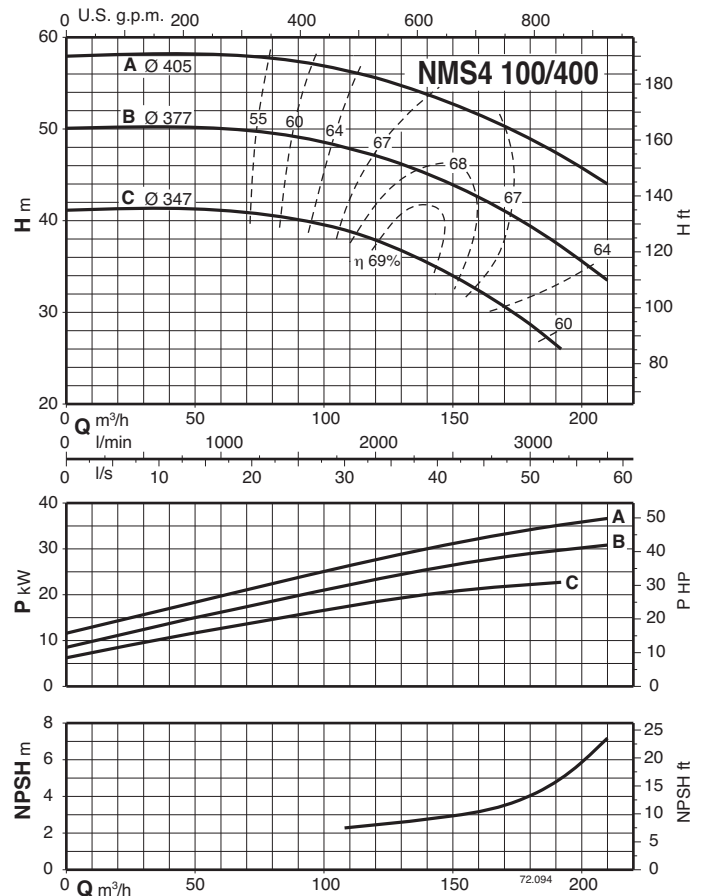
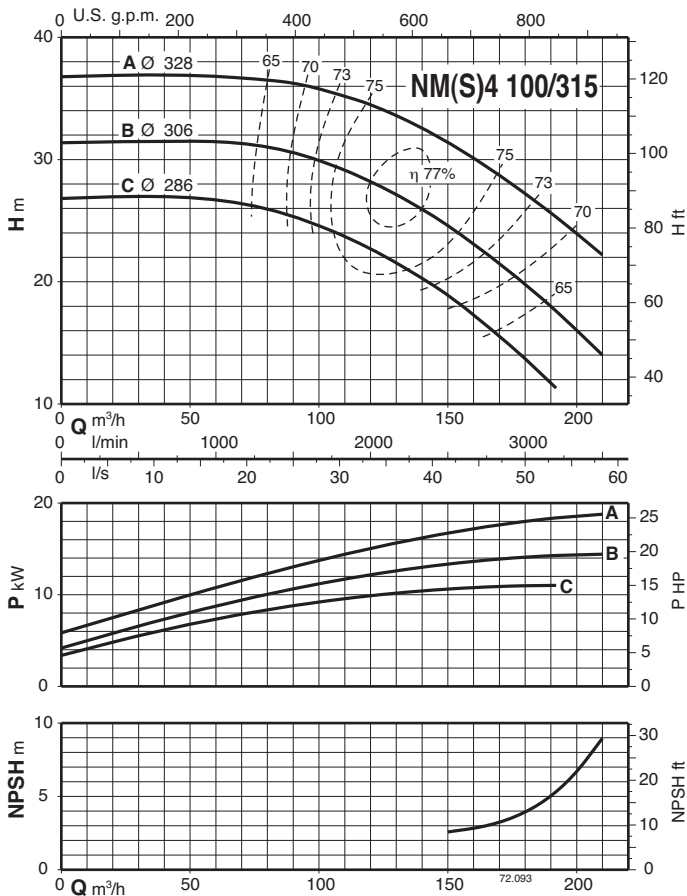
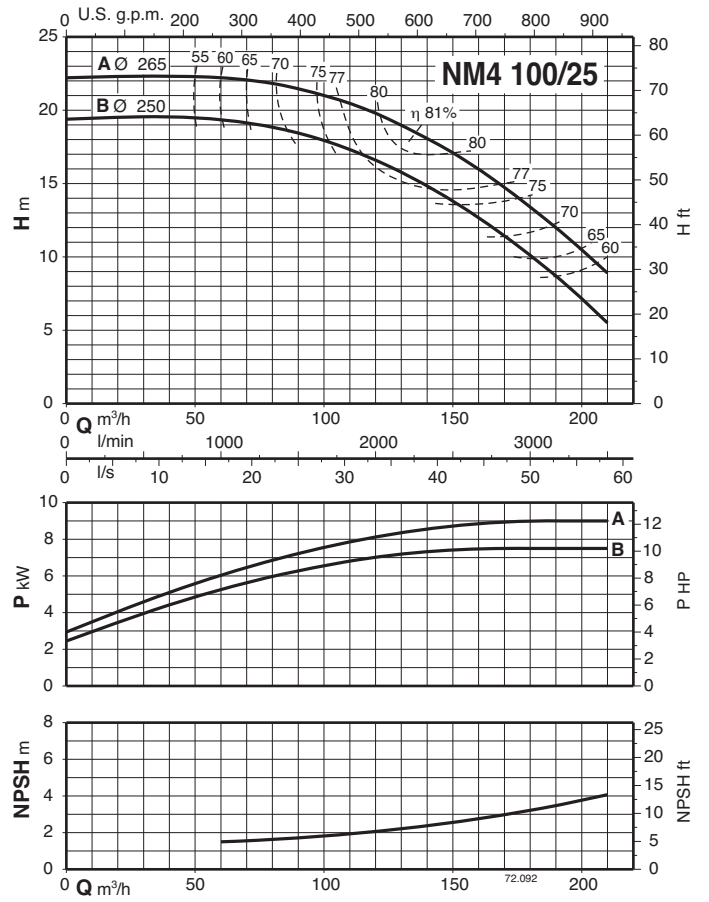
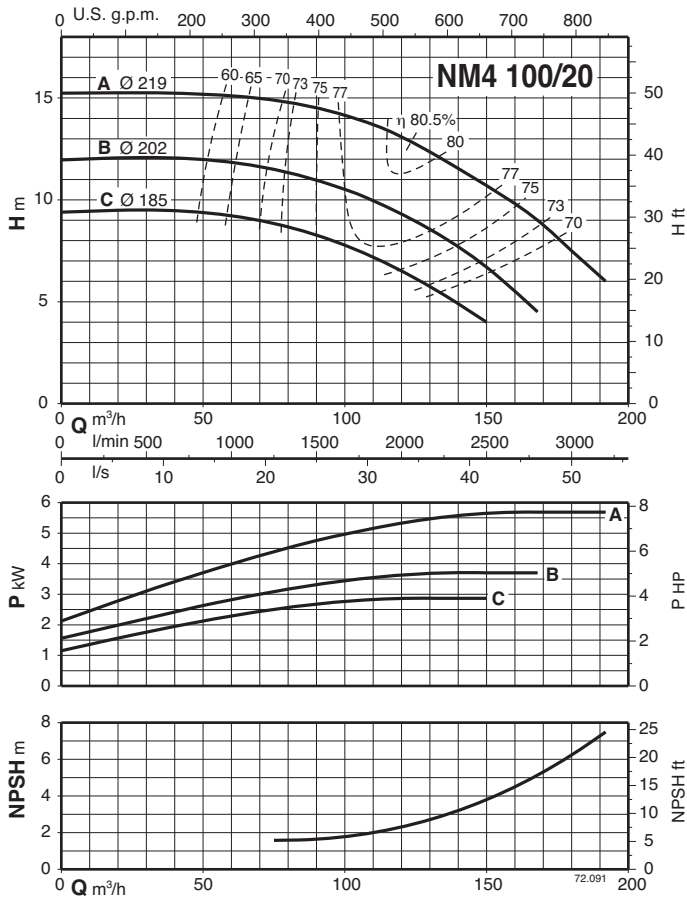

### Characteristic curves $n \approx 1450$ rpm

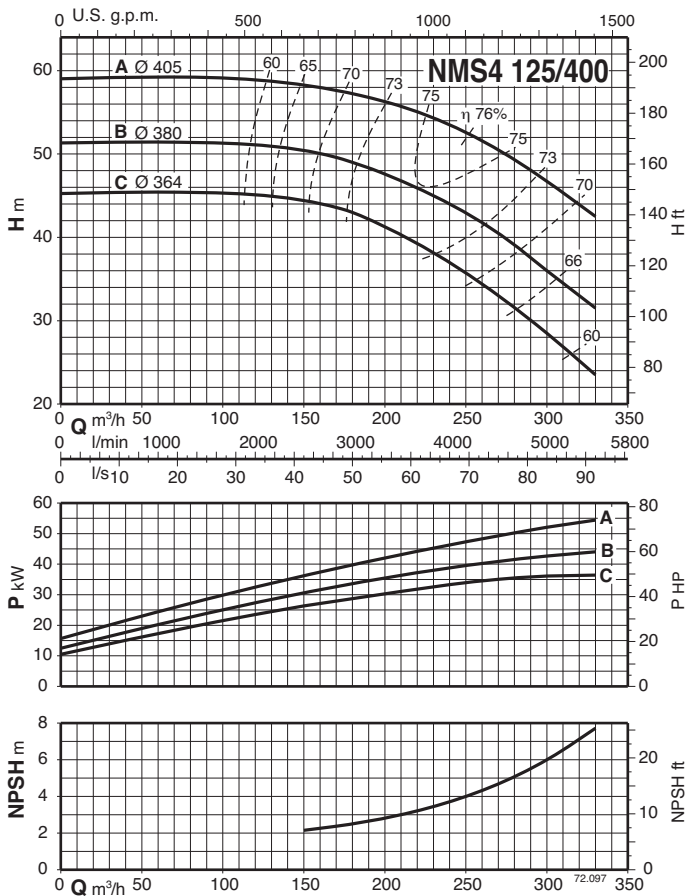
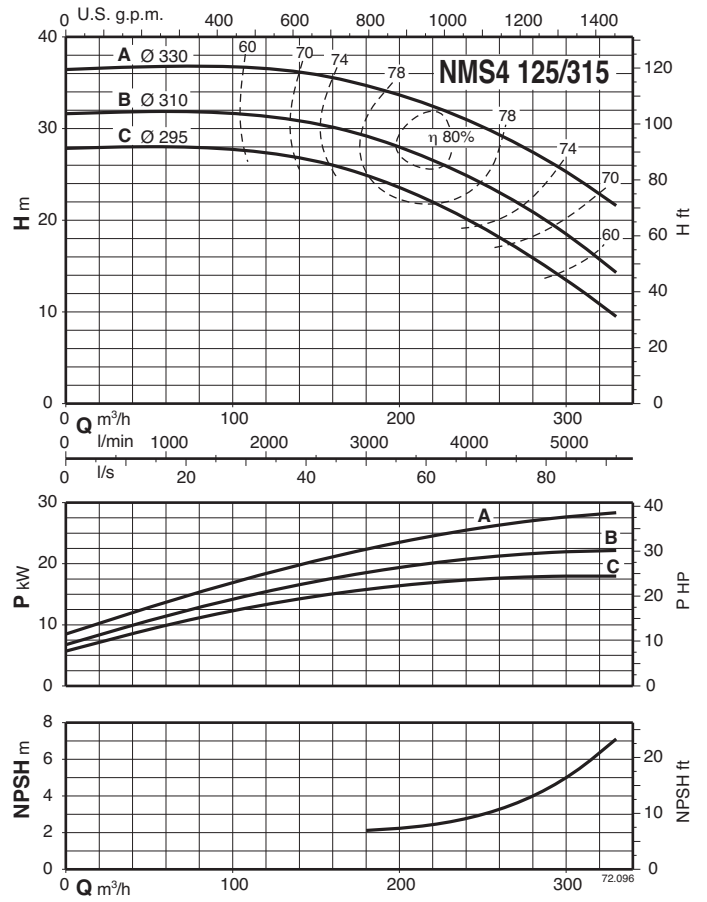
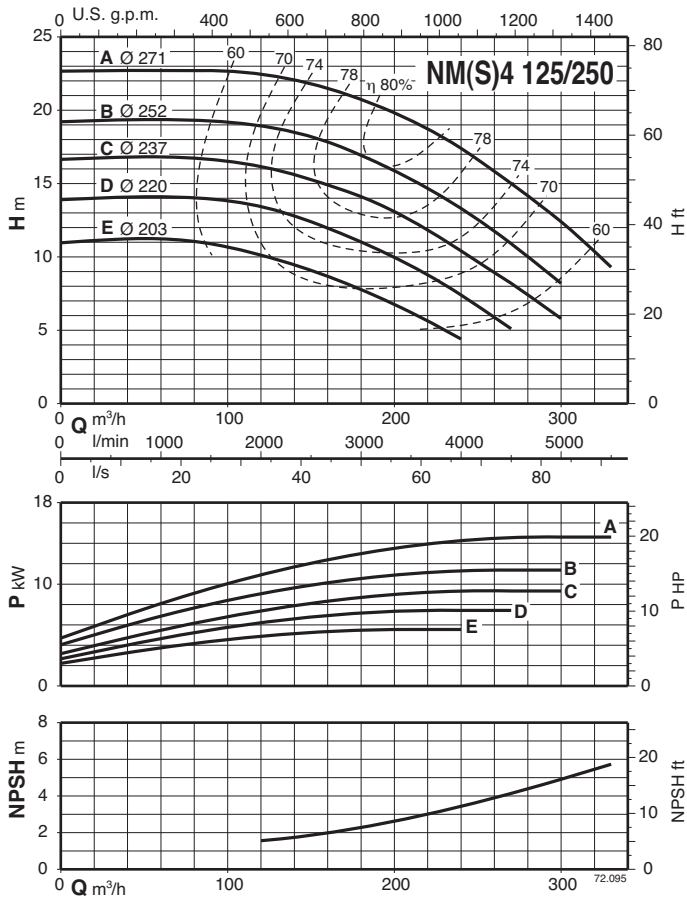

### Characteristic curves $n \approx 1450$ rpm

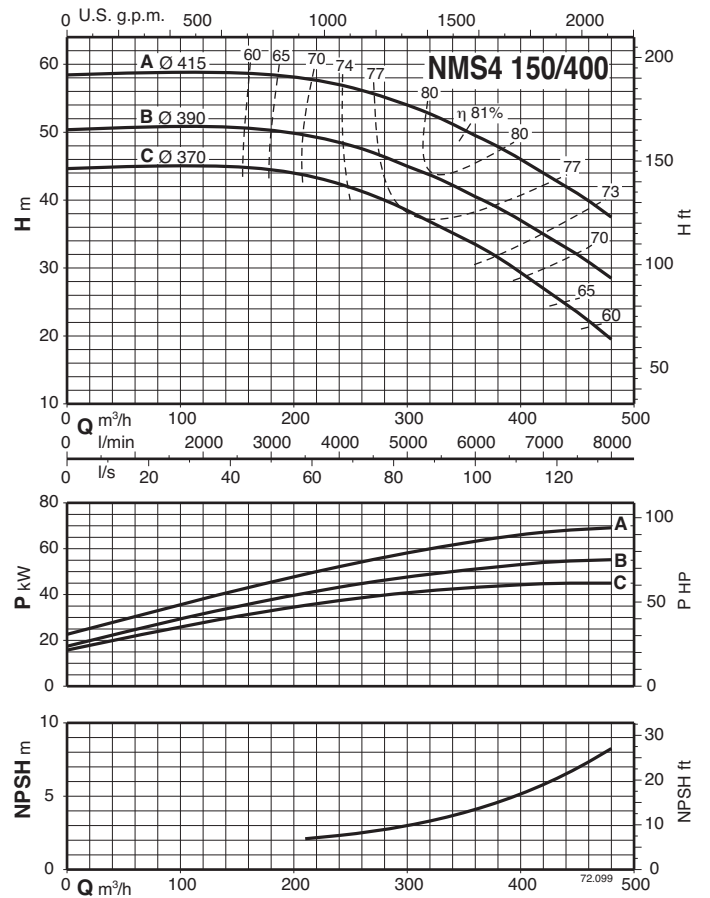
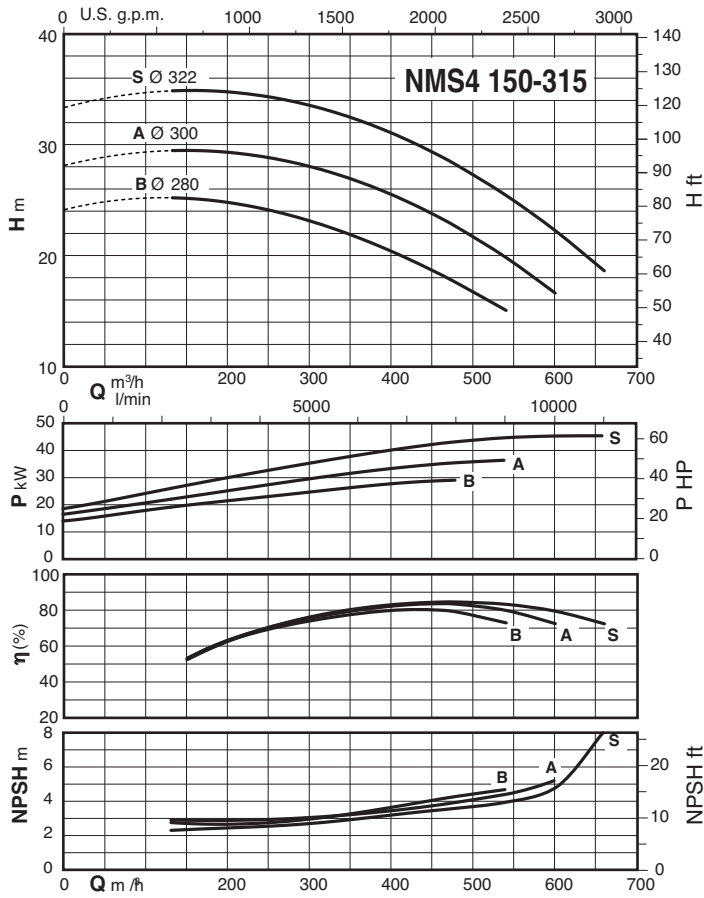



### Dimensions and weights

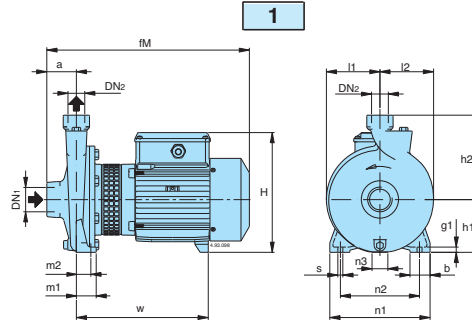

Standard construction

Picture	NM4	DN1 ISO 228	DN2	mm														kg			
				a	fM	h1	h2	H	m1	m2	n1	n2	n3	b	s	l1	l2		w	g1	
1	NM4 25/12A/A	G 1 1/2	G 1	56	313	90	140	199	37,5	27,5	170	130	9	38	9,5	85	88	250	10	12,2	
	NM4 25/160A/A-B/A			56	380	100	160	228	37,5	27,5	190	150	30	38	9,5	102	102	250	10	18,6-18,7	
	NM4 25/200B/B-C/B			63	385	125	180	253	45	32,5	245	200	49	45	45	11,5	125	125	250	11	24,5-22,6
	NM4 25/200A/C			63	425	125	180	253	45	32,5	245	200	49	45	45	11,5	125	125	250	11	29,7

2

3

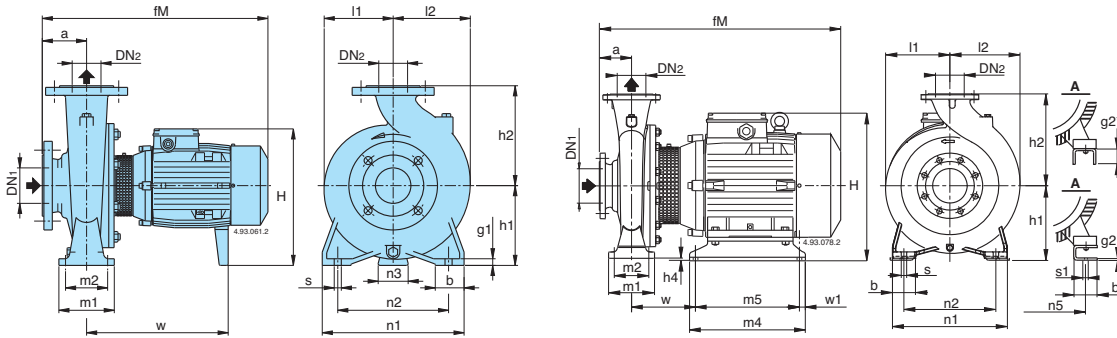

Standard construction

Picture	NM4	mm																				kg							
		DN1	DN2	a	fM	h1	h2	H	h4	m1	m2	n1	n2	n3	n5	w1	b	b1	s	s1	l1		l2	w	m4	m5	g1	g2	
2	NM4 32/16A/A-B/A	50	32	80	410	132	160	260	-	100	70	240	190	47	-	-	50	-	14	-	120	120	255	-	-	12	-	31,6-31,2	
	NM4 32/20B/A NM4 32/20A/B	50	32	80	410 450	160	180	288	-	100	70	240	190	62	-	-	50	-	14	-	140	140	255	-	-	12	-	35,8 41	
	NM4 40/16B/B-C/B NM4 40/16A/C	65	40	80	410 450	132	160	268	-	100	70	240	190	47	-	-	50	-	14	-	121	121	255	-	-	10	-	33,2-31,4 38,2	
	NM4 40/20A/B-B/B	65	40	100	495	160	180	298	-	100	70	265	212	62	-	-	50	-	14	-	142	142	295	-	-	12	-	49,6-49,6	
	NM4 40/25C/C NM4 40/25A/B-B/C	65	40	100	495 528	180	225	308 340	-	125	95	320	250	60	-	-	65	-	14	-	175	175	300 279	-	-	15	-	66,7 78-77,6	
	NM4 50/16A/C-B/C NM4 50/20A/C	65	50	100	495 528	160	200	288 320	-	100	70	265	212	62 60	-	-	50	-	14	-	140	153	310 279	-	-	14	-	56,4-53,1 64,7	
	NM4 50/25C/C-D/B NM4 50/25A/B-B/B	65	50	100	528	180	225	340	-	125	95	320	250	60	-	-	65	-	14	-	175	175	279	-	-	15	-	79,2-78,7 85,5-81	
	NM4 65/16A/C-B-C/C NM4 65/16S/A	80	65	100	495 528	160	200	288 320	-	125	95	280	212	62 60	-	-	65	-	14	-	140	161	300 279	-	-	12	-	52,4-49,3-48,7 62,3	
	NM4 65/20A/B-B/C	80	65	100	528	180	225	340	-	125	95	320	250	60	-	-	65	-	14	-	159	178	279	-	-	12	-	69-68,7	
	NM4 65/25B/C NM4 65/25A/B	80	65	100	543 645	200	250	360 385	-	160	120	360	280	60	-	-	80	-	18	-	179	195	294 405	-	-	15	-	96,6 115,5	
	NM4 65/31C/B-B/B NM4 65/31A/B	80	65	125	670 720	225	280	410	-	160	120	400	315	75	-	-	80	-	18	-	220	220	415 465	-	-	20	-	156-164 168	
	NM4 80/16B/C-C/B NM4 80/16A/C	100	80	125	520 553	180	225	308 340	-	125	95	320	250	62 60	-	-	65	-	14	-	153	181	300 279	-	-	12	-	59,6-55,6 69,8	
	NM4 80/20A/A-B/A-C/B	100	80	125	563	180	250	340	-	125	95	345	280	60	-	-	65	-	14	-	170	194	289	-	-	15	-	88-81,3-78,8	
	NM4 80/25C/A NM4 80/25B/A-B NM4 80/31C/B	100	80	125	563 670	200	280	360 385	-	160	120	400	315	60	-	-	80	-	18	-	191	210	289 415	-	-	20	-	101 120-131	
	NM4 80/31A-B	100	80	125	720	250	315	435	-	160	120	400	315	90	-	-	80	-	18	-	222	234	465	-	-	17	-	142 153	
	3	NM4 100/31A-B	100	80	125	787	260	315	466	10	160	120	400	315	-	254	20	80	74	18	14	222	234	147	435	395	-	6	226-212
		NM4 100/20B/A-C/A NM4 100/20A/C	125	100	125	563 665	200	280	360 385	-	160	120	360	280	60	-	-	80	-	18	-	180	212	289 400	-	-	20	-	91,4-83,5 109
	2	NM4 100/25B/B NM4 100/25A/B	125	100	140	685 735	225	280	410	-	160	120	400	315	75	-	-	80	-	18	-	205	233	415 465	-	-	20	-	142 153
		NM4 100/31B-C	125	100	140	802	260	315	466	10	160	120	400	315	-	254	20	80	74	18	14	230	250	147	435	395	-	6	236-221
	3	NM4 125/25E/B-D/B NM4 125/25C/B	150	125	140	685 735	250	355	435	-	160	120	400	315	90	-	-	80	-	18	-	235	268	415 465	-	-	20	-	150-160 172
NM4 125/25A-B		150	125	140	802	260	355	466	10	160	120	400	315	-	254	20	80	74	18	14	235	268	147	435	395	-	6	211-223	

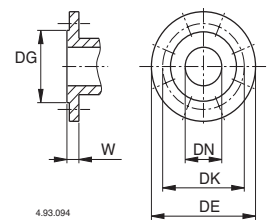

mm						
DN	DG	DK	DE	N°	Ø	
32	76	100	140	4	19	18
40	84	110	150	4	19	18
50	99	125	165	4	19	20
65	118	145	185	4	19	20
80	132	160	200	8	19	22
100	156	180	220	8	19	24
125	184	210	250	8	19	24
150	211	240	285	8	23	26
200	266	295	340	8	23	30

### Dimensions and weights

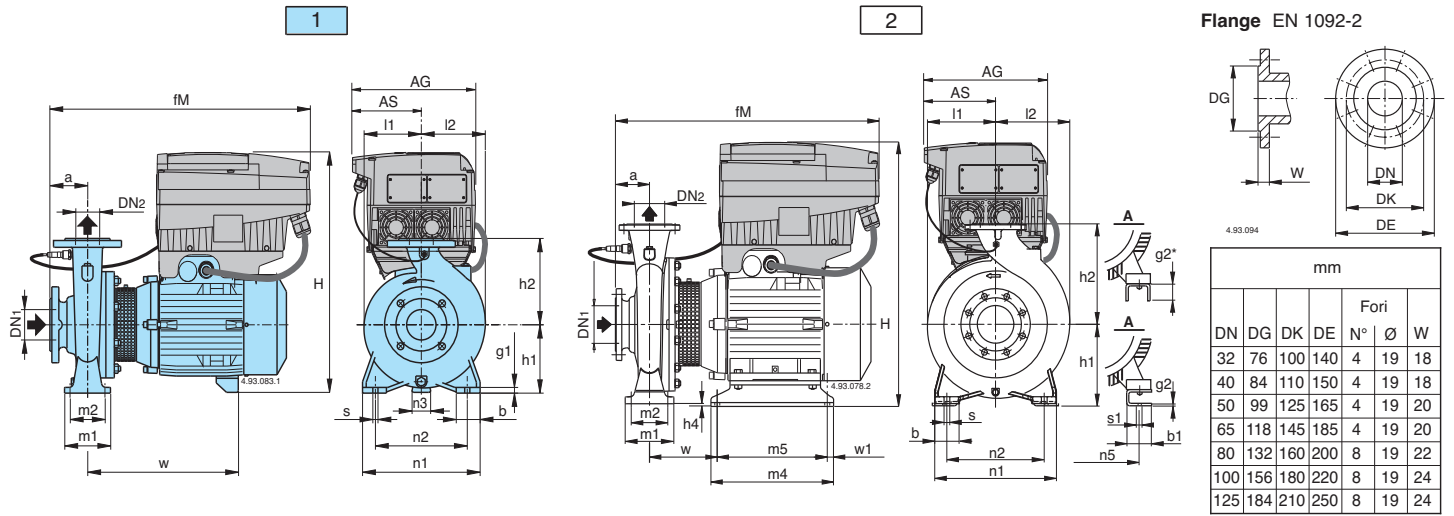

Picture	NM4 EI	mm																										kg				
		DN1	DN2	a	fM	AG	AS	h1	h2	H	h4	m1	m2	n1	n2	n3	n5	w1	b	b1	s	s1	l1	l2	w	m4	m5		g1	g2		
1	NM4 EI 32/16A/A-B/A	50	32	80	440	190	105	132	160	418	-	100	70	240	190	47	-	-	50	-	14	-	120	120	255	-	-	12	-	38,6-38		
	NM4 EI 32/20B/A	50	32	80	440	190	105	160	180	466	-	100	70	240	190	62	-	-	50	-	14	-	140	140	255	-	-	12	-	42,5		
	NM4 EI 32/20A/B	50	32	80	450	190	105	160	180	466	-	100	70	240	190	62	-	-	50	-	14	-	140	140	255	-	-	12	-	48,4		
	NM4 EI 40/16B/B-C/B	65	40	80	440	190	105	132	160	418	-	100	70	240	190	47	-	-	50	-	14	-	121	121	255	-	-	10	-	40-38		
	NM4 EI 40/16A/C	65	40	80	450	190	105	132	160	418	-	100	70	240	190	47	-	-	50	-	14	-	121	121	255	-	-	10	-	45,4		
	NM4 EI 40/20A/B-B/B	65	40	100	495	190	105	160	180	547	-	100	70	265	212	62	-	-	50	-	14	-	142	142	295	-	-	12	-	57,4-56,9		
	NM4 EI 40/25C/C	65	40	100	495	190	105	180	225	474	502	-	125	95	320	250	60	-	-	65	-	14	-	175	175	300	279	-	-	74		
	NM4 EI 40/25A/B-B/C	65	40	100	528	210	118	180	225	502	-	125	95	320	250	60	-	-	65	-	14	-	175	175	300	279	-	-	15	-	85,5-85	
	NM4 EI 50/16A/C-B/C	65	50	100	495	190	105	160	180	454	-	100	70	265	212	62	-	-	50	-	14	-	126	140	295	-	-	12	-	46,4-46		
	NM4 EI 50/20B/C-C/C	65	50	100	505	190	105	160	200	454	482	-	100	70	265	212	62	-	-	50	-	14	-	140	153	310	279	-	-	14	-	59-51
	NM4 EI 50/20A/C	65	50	100	528	210	118	180	225	502	-	125	95	320	250	60	-	-	65	-	14	-	175	175	279	-	-	15	-	63,4		
	NM4 EI 50/25C/C-D/B	65	50	100	528	210	118	180	225	502	-	125	95	320	250	60	-	-	65	-	14	-	175	175	279	-	-	15	-	74,4-74,4		
	NM4 EI 50/25A/B-B/B	65	50	100	528	210	118	180	225	502	-	125	95	320	250	60	-	-	65	-	14	-	175	175	279	-	-	15	-	93,0-85,5		
	NM4 EI 65/16B/C-C/C	80	65	100	495	190	105	160	200	454	-	125	95	280	212	62	-	-	65	-	14	-	140	161	300	279	-	-	15	-	54,4-54,4	
NM4 EI 65/16A/C	80	65	100	495	190	105	160	200	454	-	125	95	280	212	62	-	-	65	-	14	-	140	161	300	279	-	-	15	-	60,9		
NM4 EI 65/16S/A	80	65	100	528	210	118	180	225	502	-	125	95	280	212	60	-	-	65	-	14	-	140	161	300	279	-	-	15	-	61,4		
NM4 EI 65/20A/B-B/C	80	65	100	528	210	118	180	225	502	-	125	95	320	250	60	-	-	65	-	14	-	159	179	279	-	-	12	-	81-67,4			
NM4 EI 65/25B/C	80	65	100	543	210	118	200	250	522	593	-	160	120	360	280	60	-	-	80	-	18	-	179	195	294	405	-	-	15	-	104,5	
NM4 EI 65/25A/B	80	65	100	645	281	153	200	250	593	-	160	120	360	280	60	-	-	80	-	18	-	179	195	405	-	-	15	-	130,8			
NM4 EI 65/31C/B-B/B	80	65	125	670	281	153	225	280	618	-	160	120	400	315	75	-	-	80	-	18	-	220	220	415	465	-	-	20	-	179-168		
NM4 EI 65/31A/B	80	65	125	720	281	153	225	280	618	-	160	120	400	315	75	-	-	80	-	18	-	220	220	465	-	-	20	-	190,8			
NM4 EI 80/16B/C-C/B	100	80	125	520	190	105	180	225	454	545	-	125	95	320	250	62	-	-	65	-	14	-	153	181	300	279	-	-	12	-	67,4-59,4	
NM4 EI 80/16A/C	100	80	125	553	210	118	180	225	545	-	125	95	320	250	60	-	-	65	-	14	-	153	181	279	-	-	12	-	71,9			
NM4 EI 80/20A/A-B/A-C/B	100	80	125	563	210	118	180	250	502	-	125	95	345	280	60	-	-	65	-	14	-	170	194	289	-	-	15	-	99-90-81			
NM4 EI 80/25C/A	100	80	125	563	210	118	200	280	522	593	-	160	120	400	315	60	-	-	80	-	18	-	191	210	289	415	-	-	20	-	109,5	
NM4 EI 80/25B/B-A/B	100	80	125	670	281	153	200	280	593	-	160	120	400	315	60	-	-	80	-	18	-	191	210	415	-	-	20	-	150-139			
NM4 EI 80/31C/B	100	80	125	745	281	153	250	315	613	-	160	120	400	315	90	-	-	80	-	18	-	222	234	465	-	-	17	-	195,8			
2	NM4 EI 80/31B	100	80	125	790	281	260	315	671	751	10	160	120	400	315	-	254	20	80	74	18	14	222	234	147	435	395	-	6	283		
	NM4 EI 80/31A	100	80	125	350	190	260	315	751	-	160	120	400	315	-	254	20	80	74	18	14	222	234	147	435	395	-	6	304			
1	NM4 EI 100/20B/A-C/A	125	100	125	563	210	200	280	522	593	-	160	120	360	280	60	-	-	80	-	18	-	180	212	289	400	-	-	20	-	107-97,5	
	NM4 EI 100/20A/C	125	100	125	665	281	200	280	593	-	160	120	360	280	60	-	-	80	-	18	-	180	212	400	-	-	20	-	123,8			
2	NM4 EI 100/25B/B	125	100	140	685	281	225	280	618	-	160	120	400	315	75	-	-	80	-	18	-	205	233	415	465	-	-	20	-	166,8		
	NM4 EI 100/25A/B	125	100	140	735	281	225	280	618	-	160	120	400	315	75	-	-	80	-	18	-	205	233	465	-	-	20	-	157,8			
1	NM4 EI 100/31C	125	100	140	805	281	260	315	671	751	10	160	120	400	315	-	254	20	80	74	18	14	230	250	147	435	395	-	6	296		
	NM4 EI 100/31B	125	100	140	350	190	260	315	751	-	160	120	400	315	-	254	20	80	74	18	14	230	250	147	435	395	-	6	315			
2	NM4 EI 125/25E/B-D/B	150	125	140	685	281	250	355	643	-	160	120	400	315	90	-	-	80	-	18	-	235	268	415	465	-	-	20	-	164-176		
	NM4 EI 125/25C/B	150	125	140	735	281	250	355	643	-	160	120	400	315	90	-	-	80	-	18	-	235	268	465	-	-	20	-	187,8			
1	NM4 EI 125/25B	150	125	140	805	281	260	355	671	751	10	160	120	400	315	-	254	20	80	74	18	14	235	268	147	435	395	-	6	378		
	NM4 EI 125/25A	150	125	140	350	190	260	355	751	-	160	120	400	315	-	254	20	80	74	18	14	235	268	147	435	395	-	6	296			

### Dimensions and weights

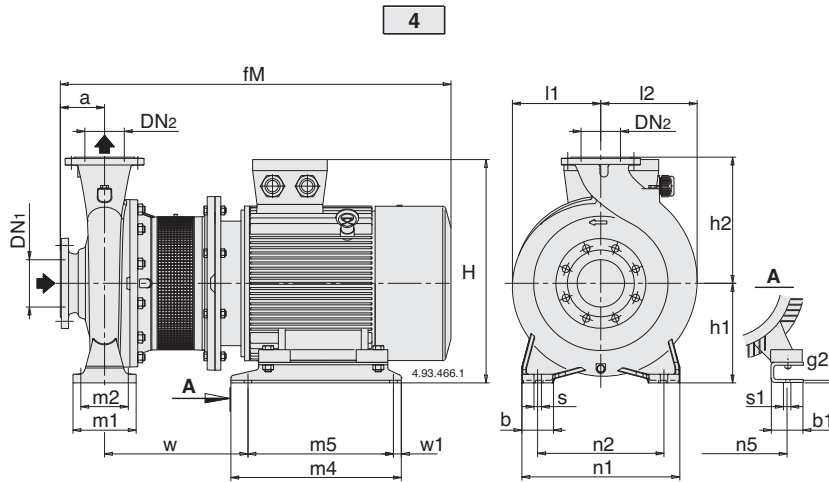

Flanges EN 1092-2

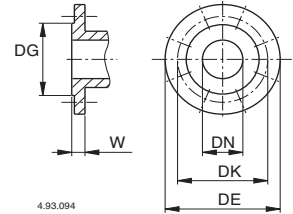

mm						
DN	DG	DK	DE	Holes		W
				N°	Ø	
32	76	100	140	4	19	18
40	84	110	150	4	19	18
50	99	125	165	4	19	20
65	118	145	185	4	19	20
80	132	160	200	8	19	22
100	156	180	220	8	19	24
125	184	210	250	8	19	24
150	211	240	285	8	23	26
200	266	295	340	8	23	30

Standard construction

Picture	NMS4	mm																				kg			
		DN <sub>1</sub>	DN <sub>2</sub>	a	fM	h <sub>1</sub>	h <sub>2</sub>	H	m <sub>1</sub>	m <sub>2</sub>	n <sub>1</sub>	n <sub>2</sub>	n <sub>5</sub>	w <sub>1</sub>	b	b <sub>1</sub>	s	s <sub>1</sub>	l <sub>1</sub>	l <sub>2</sub>	w		m <sub>4</sub>	m <sub>5</sub>	g <sub>2</sub>
4	NMS4 80/315S	100	80	125	999	250	315	509	160	120	400	315	279	25	80	70	18	15	222	234	312	432	382	6	
	NMS4 80/400C/B	125	80	125	1004	280	355	539	160	120	435	355	279	25	80	70	18	15	268	269	318	520	435	6	339
	NMS4 80/400B/B	125	80	125	1004	280	355	539	160	120	435	355	279	25	80	70	18	15	268	269	318	520	435	6	355
	NMS4 80/400A/B	125	80	125	1051	280	355	576	160	120	435	355	318	25	80	83	18	19	268	269	334	540	455	6	413
	NMS4 80/400S	125	80	125	1118	280	355	618	160	120	435	355	356	55	80	103	18	19	268	269	379	540	460	8	490
	NMS4 100/315A/A	125	100	140	1014	250	315	509	160	120	400	315	279	25	80	70	18	15	230	250	312	432	382	6	308
	NMS4 100/400C/A	125	100	140	1019	280	355	539	200	150	500	400	279	25	100	70	22	15	268	280	318	520	435	6	366
	NMS4 100/400B/A	125	100	140	1066	280	355	576	200	150	500	400	318	25	100	83	22	19	268	280	334	540	455	6	419
	NMS4 100/400A/A	125	100	140	1138	280	355	618	200	150	500	400	356	55	100	103	22	19	268	280	384	540	460	8	506
	NMS4 125/315C/A	150	125	140	1019	280	355	539	200	150	500	400	279	25	100	70	22	15	247	278	318	520	435	6	331
	NMS4 125/315B/A	150	125	140	1019	280	355	539	200	150	500	400	279	25	100	70	22	15	247	278	318	520	435	6	350
	NMS4 125/315A/A	150	125	140	1066	280	355	576	200	150	500	400	318	25	100	83	22	19	247	278	334	540	455	6	409
	NMS4 125/400C/A	150	125	140	1138	315	400	653	200	150	500	400	356	25	100	103	22	19	280	305	409	540	461	8	524
	NMS4 125/400B/A	150	125	140	1198	315	400	653	200	150	500	400	356	25	100	103	22	19	280	305	409	540	461	8	574
	NMS4 125/400A/A	150	125	140	1237	315	400	725	200	150	500	400	406	25	100	100	22	24	280	305	454	540	461	8	665
	NMS4 150/315B/B	200	150	160	1086	280	400	576	200	150	550	450	318	25	100	83	22	19	256	307	334	540	455	6	412
	NMS4 150/315A/B	200	150	160	1158	280	400	618	200	150	550	450	356	55	100	103	22	19	256	307	384	540	460	8	492
	NMS4 150/315S	200	150	160	1218	280	400	618	200	150	550	450	356	55	100	103	22	19	256	307	384	540	460	8	541
	NMS4 150/400C/A	200	150	160	1218	315	450	653	200	150	550	450	356	25	100	103	22	19	295	328	409	540	461	8	594
	NMS4 150/400B/A	200	150	160	1257	315	450	725	200	150	550	450	406	25	100	100	22	24	295	328	454	540	461	8	681
NMS4 150/400A/A	200	150	160	1330	315	450	748	200	150	550	450	457	45	100	100	22	24	295	328	482	625	368	35	845	

### Dimensions and weights

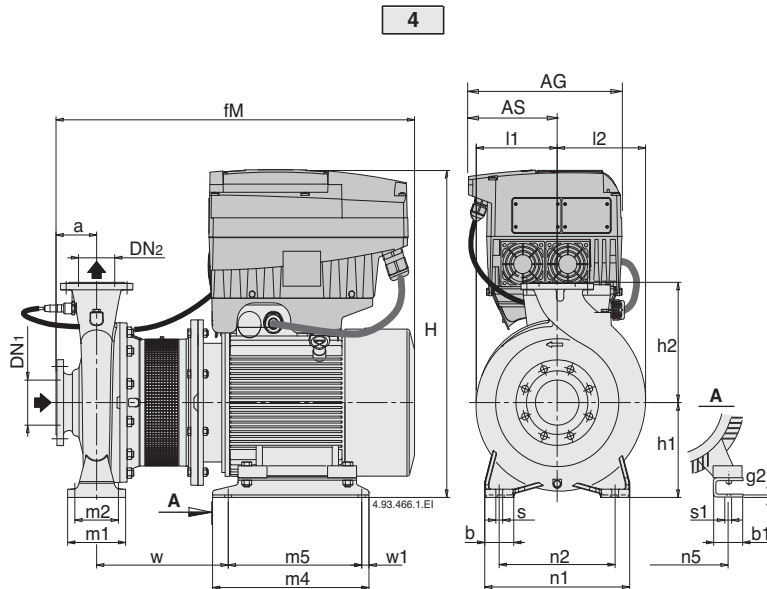

Flanges EN 1092-2

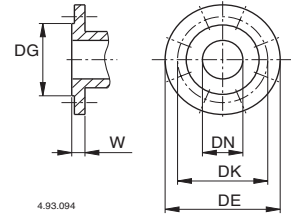

mm						
DN	DG	DK	DE	Holes		W
				N°	Ø	
32	76	100	140	4	19	18
40	84	110	150	4	19	18
50	99	125	165	4	19	20
65	118	145	185	4	19	20
80	132	160	200	8	19	22
100	156	180	220	8	19	24
125	184	210	250	8	19	24
150	211	240	285	8	23	26
200	266	295	340	8	23	30

Picture	NMS4 EI	mm																							kg		
		DN1	DN2	a	fM	AG	AS	h1	h2	H	m1	m2	n1	n2	n5	w1	b	b1	s	s1	l1	l2	w	m4		m5	g2
4	NMS4 EI 80/315S	100	80	125	998	350	190	250	315	785	160	120	400	315	279	25	80	70	18	15	222	234	312	432	382	6	374
	NMS4 EI 80/400C/B	125	80	125	1003	350	190	280	355	815	160	120	435	355	279	25	80	70	18	15	268	269	318	520	435	6	390
	NMS4 EI 80/400B/B	125	80	125	1003	350	190	280	355	815	160	120	435	355	279	25	80	70	18	15	268	269	318	520	435	6	390
	NMS4 EI 80/400A/B	125	80	125	1051	350	190	280	355	858	160	120	435	355	318	25	80	83	18	19	268	269	334	540	455	6	448
	NMS4 EI 100/315A/A	125	100	140	1013	350	190	250	315	785	160	120	400	315	279	25	80	70	18	15	230	250	312	432	382	6	343
	NMS4 EI 100/400C/A	125	100	140	1018	350	190	280	355	815	200	150	500	400	279	25	100	70	22	15	268	280	318	520	435	6	401
	NMS4 EI 100/400B/A	125	100	140	1066	350	190	280	355	858	200	150	500	400	318	25	100	83	22	19	268	280	334	540	455	6	454
	NMS4 EI 125/315C/A	150	125	140	1018	350	190	280	355	815	200	150	500	400	279	25	100	70	22	15	247	278	318	520	435	6	366
	NMS4 EI 125/315B/A	150	125	140	1018	350	190	280	355	815	200	150	500	400	279	25	100	70	22	15	247	278	318	520	435	6	385
	NMS4 EI 125/315A/A	150	125	140	1066	350	190	280	355	858	200	150	500	400	318	25	100	83	22	19	247	278	334	540	455	6	444
NMS4 EI 150/315B/B	200	150	160	1086	350	190	280	400	858	200	150	550	450	318	25	100	83	22	19	256	307	334	540	455	6	447	

### Dimensions and weights

1

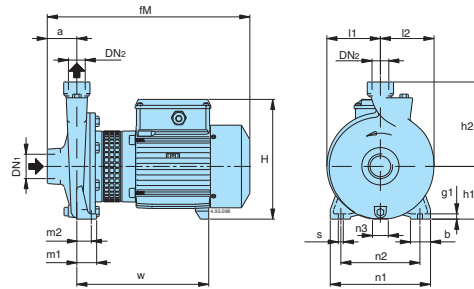

Bronze construction B-NM4

Picture	B-NM4	DN1 ISO 228	DN2	mm																	kg
				a	fM	h1	h2	H	m1	m2	n1	n2	n3	b	s	l1	l2	w	g1		
1	B-NM4 25/160A/A-B/A	G 1 1/2	G 1	56	380	100	160	228	37,5	27,5	190	150	30	38	9,5	102	102	250	10	21,1-21	
	B-NM4 25/200B/B-C/B			63	400	125	180	253	45	32,5	245	200	49	45	11,5	125	125	250	11	28,4-26,5	
	B-NM4 25/200A/C			63	445	125	180	253	45	32,5	245	200	49	45	11,5	125	125	303	11	34,2	

2

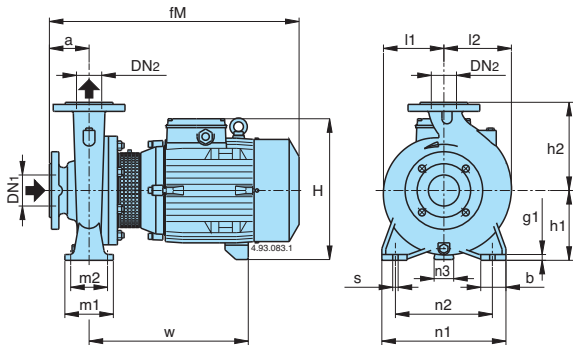

3

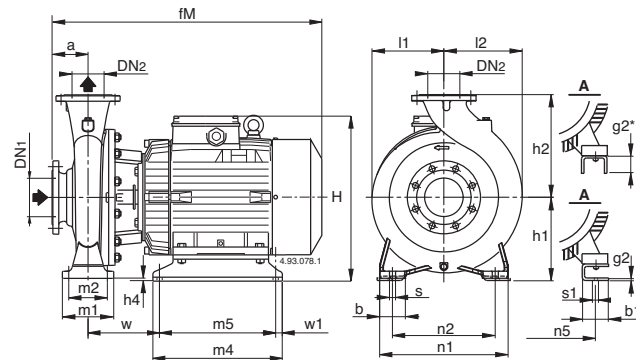

Bronze construction B-NM4

Picture	B-NM4	DN1	DN2	mm																				kg							
				a	fM	h1	h2	H	h4	m1	m2	n1	n2	n3	n5	w1	b	b1	s	s1	l1	l2	w		m4	m5	g1	g2			
2	B-NM4 32/16A/A-B/A	50	32	80	410	132	160	260	-	100	70	240	190	47	-	-	50	-	14	-	120	120	255	-	-	12	-	35-34			
	B-NM4 32/20B/A	50	32	80	410	160	180	288	-	100	70	240	190	62	-	-	50	-	14	-	140	140	255	-	-	12	-	43			
	B-NM4 32/20A/A	50	32	80	450	160	180	288	-	100	70	240	190	62	-	-	50	-	14	-	140	140	255	-	-	12	-	45			
	B-NM4 40/16B/A-C/A	65	40	80	410	132	160	260	-	100	70	240	190	47	-	-	50	-	14	-	121	121	255	-	-	10	-	37,4-35,5			
3	B-NM4 40/16A/B	65	40	80	450	132	160	260	-	100	70	240	190	47	-	-	50	-	14	-	121	121	255	-	-	10	-	43			
	B-NM4 40/20A/B-B/B	65	40	100	495	160	180	298	-	100	70	265	212	62	-	-	50	-	14	-	142	142	295	-	-	12	-	55-55			
2	B-NM4 40/25C/C	65	40	100	535	190	225	318	10	125	95	320	250	-	140	190	15	65	54	60	14	10	12	175	175	156	205	175	6	73	
	B-NM4 40/25A/B-B/C	65	40	100	560	190	225	350	10	125	95	320	250	-	140	190	15	65	54	60	14	10	12	175	175	156	205	175	6	73	
2	B-NM4 50/16A/B-B/B	65	50	100	495	160	180	298	-	100	70	265	212	62	-	-	50	-	14	-	126	140	295	-	-	12	-	55-55			
	B-NM4 50/20B/C-C/C	65	50	100	505	160	200	288	320	-	100	70	265	212	62	60	-	50	-	14	-	140	153	310	279	-	-	14	-	-	
3	B-NM4 50/20A/C	65	50	100	528	160	200	288	320	-	100	70	265	212	62	60	-	50	-	14	-	140	153	310	279	-	-	14	-	-	
	B-NM4 50/25C/C-D/B	65	50	100	560	190	225	350	10	125	95	320	250	-	190	15	65	60	14	12	175	175	125	280	250	-	6	79,5			
2	B-NM4 50/25A/B-B/B	65	50	100	528	160	200	288	320	-	100	70	265	212	62	60	-	50	-	14	-	140	153	310	279	-	-	14	-	105-92	
	B-NM4 50/25A/B-B/B	65	50	100	560	190	225	350	10	125	95	320	250	-	190	15	65	60	14	12	175	175	125	280	250	-	6	79,5			
2	B-NM4 65/16A/C-B/C-C/C	80	65	100	495	160	200	306	320	-	125	95	280	212	62	60	-	65	-	14	-	140	161	300	279	-	-	12	-	60-57-66	
	B-NM4 65/16S/A	80	65	100	528	160	200	306	320	-	125	95	280	212	62	60	-	65	-	14	-	140	161	300	279	-	-	12	-	69,8	
	B-NM4 65/20A/A-B/A	80	65	100	528	180	225	340	-	125	95	320	250	60	-	-	65	-	14	-	159	179	279	-	-	12	-	-	-	-	
	B-NM4 65/25B/B	80	65	100	540	200	250	360	385	-	160	120	360	280	60	-	-	80	-	18	-	179	195	345	405	-	-	15	-	109	
	B-NM4 65/25A/C	80	65	100	540	200	250	360	385	-	160	120	360	280	60	-	-	80	-	18	-	179	195	345	405	-	-	15	-	128	
	B-NM4 65/31C/B-B/B	80	65	125	670	225	280	410	-	160	120	400	315	75	-	-	80	-	18	-	220	220	415	465	-	-	20	-	170-..		
	B-NM4 65/31A/B	80	65	125	720	225	280	410	-	160	120	400	315	75	-	-	80	-	18	-	220	220	415	465	-	-	20	-	-		
	B-NM4 80/20A-B-C	100	80	125	560	180	250	340	-	125	95	345	280	60	-	-	65	-	14	-	170	194	340	-	-	15	-	-	-	97,2-89,7-..	
	B-NM4 80/25C/A	100	80	125	565	200	280	360	-	160	120	400	315	60	-	-	80	-	18	-	191	210	335	-	-	20	-	-	-	115	
	B-NM4 80/31C	100	80	125	720	250	315	435	-	160	120	400	315	90	-	-	80	-	18	-	222	234	465	-	-	17	-	-	-	-	
2	B-NM4 100/20B/A-C/A	125	100	125	565	200	280	360	385	-	160	120	360	280	60	-	-	80	-	18	-	180	212	330	-	-	20	-	-	-	109-103
	B-NM4 100/20A/C	125	100	125	665	200	280	385	-	160	120	360	280	60	-	-	80	-	18	-	180	212	400	-	-	20	-	-	-	129	

Flanges EN 1092-2

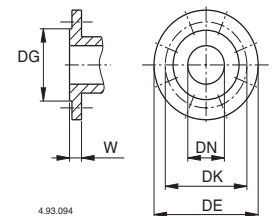

mm						
DN	DG	DK	DE	Holes		W
				N°	Ø	
32	76	100	140	4	19	18
40	84	110	150	4	19	18
50	99	125	165	4	19	20
65	118	145	185	4	19	20
80	132	160	200	8	19	22
100	156	180	220	8	19	24
125	184	210	250	8	19	24
150	211	240	285	8	23	26
200	266	295	340	8	23	30



### Dimensions and weights

Flanges EN 1092-2

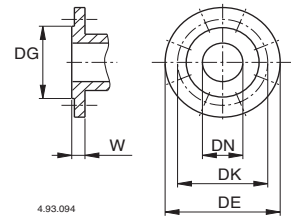
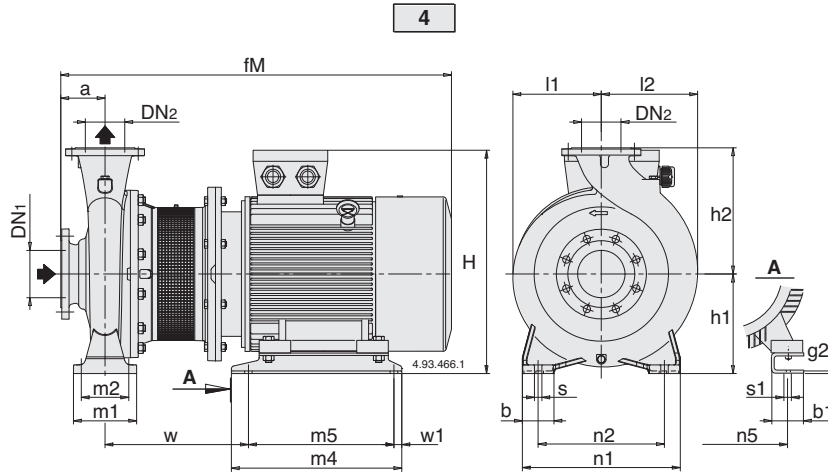

mm						
DN	DG	DK	DE	Holes		W
				N°	Ø	
32	76	100	140	4	19	18
40	84	110	150	4	19	18
50	99	125	165	4	19	20
65	118	145	185	4	19	20
80	132	160	200	8	19	22
100	156	180	220	8	19	24
125	184	210	250	8	19	24
150	211	240	285	8	23	26
200	266	295	340	8	23	30

Bronze construction **B-NM4**

Picture	B-NMS4	mm																				kg				
		DN1	DN2	a	fM	h1	h2	H	m1	m2	n1	n2	n5	w1	b	b1	s	s1	l1	l2	w		m4	m5	g2	
4	BNMS4 80/250A/A-B/A	100	80	125	807	200	280	387	160	120	400	315	216	20	80	69	18	12	191	210	322	298	258	6	181-171	
	BNMS4 80/315B/B	100	80	125	948	250	315	457	160	120	400	315	254	20	80	60	18	15	222	234	271	435	395	6		
	BNMS4 80/315A/B	100	80	125	948	250	315	457	160	120	400	315	254	20	80	60	18	15	222	234	271	435	395	6		
	BNMS4 80/315S	100	80	125	999	250	315	509	160	120	400	315	279	25	80	70	18	15	222	234	312	432	382	6		
	BNMS4 80/400C/B	125	80	125	1004	280	355	539	160	120	435	355	279	25	80	70	18	15	268	269	318	520	435	6		
	BNMS4 80/400B/B	125	80	125	1004	280	355	539	160	120	435	355	279	25	80	70	18	15	268	269	318	520	435	6		
	BNMS4 80/400A/B	125	80	125	1051	280	355	576	160	120	435	355	318	25	80	83	18	19	268	269	334	540	455	6		
	BNMS4 80/400S	125	80	125	1118	280	355	618	160	120	435	355	356	55	80	103	18	19	268	269	379	540	460	8		
	BNMS4 100/250B/A	125	100	140	822	225	280	412	160	120	400	315	216	20	80	69	18	12	205	233	322	298	258	6		192
	BNMS4 100/250A/A	125	100	140	872	225	280	412	160	120	400	315	216	20	80	69	18	12	205	233	322	298	258	6		206
	BNMS4 100/315C/A	125	100	140	963	250	315	457	160	120	400	315	254	20	80	60	18	15	230	250	271	435	395	6		284
	BNMS4 100/315B/A	125	100	140	963	250	315	457	160	120	400	315	254	20	80	60	18	15	230	250	298	435	395	6		300
	BNMS4 100/315A/A	125	100	140	1014	250	315	509	160	120	400	315	279	25	80	70	18	15	230	250	312	432	382	6		
	BNMS4 100/400C/A	125	100	140	1019	280	355	539	200	150	500	400	279	25	100	70	22	15	268	280	318	520	435	6		
	BNMS4 100/400B/A	125	100	140	1066	280	355	576	200	150	500	400	318	25	100	83	22	19	268	280	334	540	455	6		
	BNMS4 100/400A/A	125	100	140	1138	280	355	618	200	150	500	400	356	55	100	103	22	19	268	280	384	540	460	8		
	BNMS4 125/250D/A-E/A	150	125	140	822	250	355	437	160	120	400	315	216	20	80	69	18	12	235	268	322	298	258	6		
	BNMS4 125/250C/A	150	125	140	872	250	355	437	160	120	400	315	216	20	80	69	18	12	235	268	322	298	258	6		
	BNMS4 125/250B/A	150	125	140	951	250	355	457	160	120	400	315	254	20	80	60	18	15	235	268	259	435	395	6		265
	BNMS4 125/250A/A	150	125	140	951	250	355	457	160	120	400	315	254	20	80	60	18	15	235	268	259	435	395	6		273
	BNMS4 125/315C/A	150	125	140	1019	280	355	539	200	150	500	400	279	25	100	70	22	15	247	278	318	520	435	6		383
	BNMS4 125/315B/A	150	125	140	1019	280	355	539	200	150	500	400	279	25	100	70	22	15	247	278	318	520	435	6		395
	BNMS4 125/315A/A	150	125	140	1066	280	355	576	200	150	500	400	318	25	100	83	22	19	247	278	334	540	455	6		
	BNMS4 125/400C/A	150	125	140	1138	315	400	653	200	150	500	400	356	25	100	103	22	19	280	305	409	540	461	8		
	BNMS4 125/400B/A	150	125	140	1198	315	400	653	200	150	500	400	356	25	100	103	22	19	280	305	409	540	461	8		
	BNMS4 125/400A/A	150	125	140	1237	315	400	725	200	150	500	400	406	25	100	100	22	24	280	305	454	540	461	8		
	BNMS4 150/315B/B	200	150	160	1086	280	400	576	200	150	550	450	318	25	100	83	22	19	256	307	334	540	455	6		
	BNMS4 150/315A/B	200	150	160	1158	280	400	618	200	150	550	450	356	55	100	103	22	19	256	307	385	540	460	8		
	BNMS4 150/315S	200	150	160	1218	280	400	618	200	150	550	450	356	55	100	103	22	19	256	307	385	540	460	8		
	BNMS4 150/400C/A	200	150	160	1218	315	450	653	200	150	550	450	356	25	100	103	22	19	295	328	410	540	461	8		
BNMS4 150/400B/A	200	150	160	1257	315	450	725	200	150	550	450	406	25	100	100	22	24	295	328	454	540	461	8			
BNMS4 150/400A/A	200	150	160	1330	315	450	748	200	150	550	450	457	45	100	100	22	24	295	328	482	625	368	35			

### Features

#### Cutting edge hydraulics

The geometry of the impeller and the pump casing are optimized to achieve maximum efficiency and the best suction capability.

#### Flexible

The option to choose between cast iron and bronze materials for the hydraulic parts in contact with the pumped liquid allows NM4 series pumps to be selected for use with different types of liquids.

#### Compact Design

The compact design allows for easy installation even in confined spaces.

#### Exclusive design

An innovative, patented guard prevents contact with rotating parts, providing protection to the end user whilst allowing for inspection of the mechanical seal.

#### Reliable

The bearing and shaft are designed to ensure the reduction of the stress, providing high reliability under all operating conditions.

NM4S

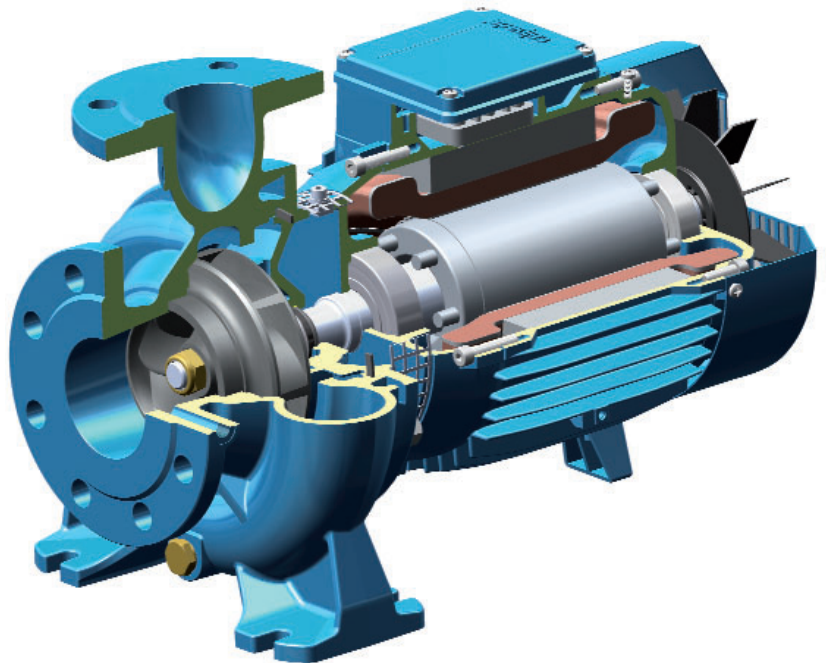

#### Cutting edge hydraulics

The geometry of the impeller and the pump casing are optimized to achieve maximum efficiency and the best suction capability.

#### Flexibility

The option to choose between cast iron and bronze materials for the hydraulic parts in contact with the pumped liquid allows NMS4 series pumps to be selected for use with different types of liquids.

#### New lantern bracket construction

The lantern brackets incorporate a thrust bearing on the hydraulic side which guarantees the elimination of additional loads on the motor bearings. The flange is sized to be used with standard motors B35.

#### Exclusive design

An innovative, patented guard prevents contact with rotating parts, providing protection to the end user whilst allowing for inspection of the mechanical seal.

#### Simplified motor maintenance

The presence of the thrust bearing on the hydraulic side makes it easier to remove the motor, facilitating maintenance operations and eliminating the risks of damage to the hydraulic parts.

NMS

